

PATTERN INSTRUCTIONS

BERGERE
DE FRANCE

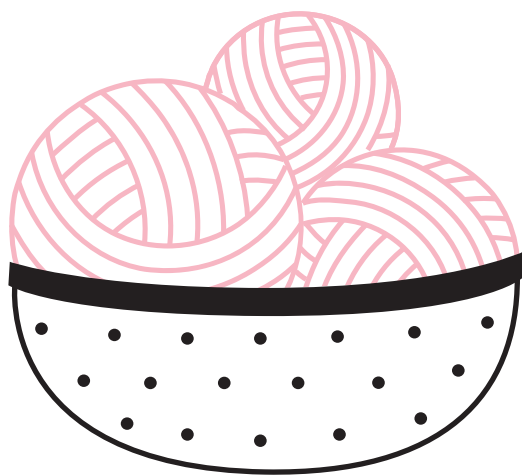

DON'T PANIC !

**BERGERE DE FRANCE IS
ACCOMPANYING ME STEP BY STEP**



OUR DEDICATED EMAIL

Stuck in the middle of your work? Need a clarification concerning the instructions? Do not hesitate to contact us. An expert knitter will take the time to provide the answers and all the help you need.

knittingquery@bergeredefrance.com

From Monday to Friday, during office hours



OUR WEBSITE

www.bergeredefrance.co.uk/knitting-basics-get-started

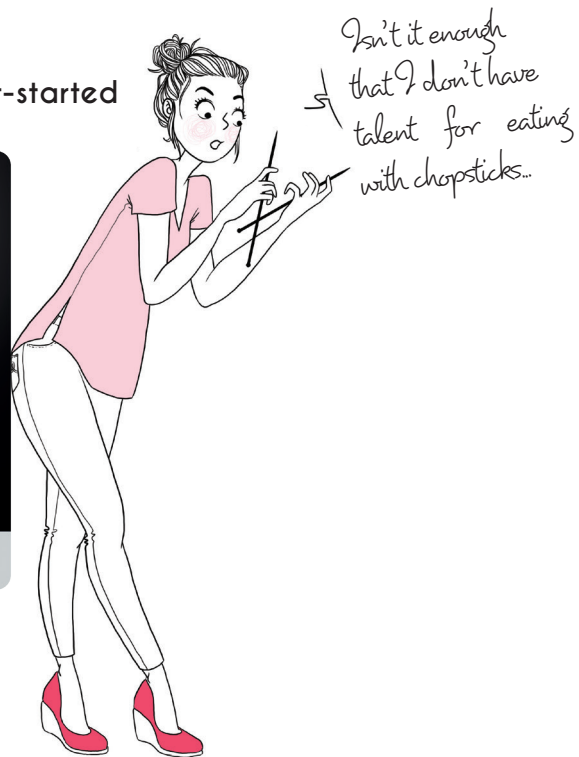
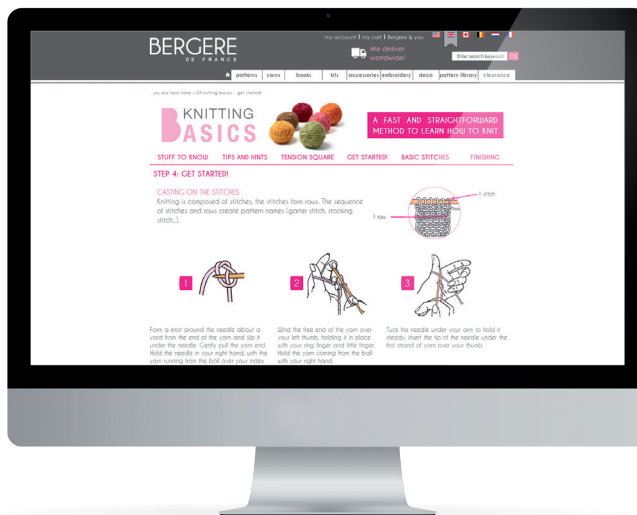

OUR YOUTUBE CHANNEL

All our video tutorials (in french) are available at :
www.youtube.com/bergerefr

Stuck in the middle of your work... Need some advice from an expert?



knittingquery@bergeredefrance.com

From Monday to Friday, during office hours

CHECK YOUR TENSION

Before you start working on a pattern, make sure that the end-result will be perfect by making a swatch.

You've got to make sure that your knitting tension is exactly the same as the tension in our pattern. If it isn't, your garment is likely to be too big or too small.

HOW TO MAKE A SWATCH ?

Using the yarn, needles, and stitch specified for the pattern, work a square at least 6 in (15 cm) on a side.

Iron the square lightly on the wrong side under a damp cloth or using a steam iron. If the swatch is worked in ribbing, stretch it slightly. With a ruler, count the sts to equal 4 in (10 cm) widthways and 4 in (10 cm) lengthways.

Compare the result with the sample given in our instructions.

Your tension square matches ours !

You can start your knitting, you can be sure your project will have the same dimensions as the grid.

Your sample has more stitches and rows ?

Your knitting is too tight. Make another swatch with needles one size larger.

Your sample has fewer stitches and rows ?

Your knitting is too loose. Make another swatch with needles one size smaller.

When your swatch matches ours, you're ready to follow the instructions.

You can expect to end up with a garment that's just right.

BEWARE: It is important to achieve an exact number of stitches for the design to fit correctly. However, the number of rows can be adapted depending on the height indicated in cm.



Read the instructions

Before you start knitting we advise you to read through the instructions, trying to imagine all of the steps you will be taking. All patterns are well detailed.

The instructions are given for several sizes. We suggest that you circle or underline the numbers that correspond to the size you intend to make. If there's only one number, it applies to all the sizes.

I LEARN THE BASICS

Knitting is composed of stitches, the stitches form rows. The sequence of stitches and rows create pattern names (garter stitch, stocking st...).

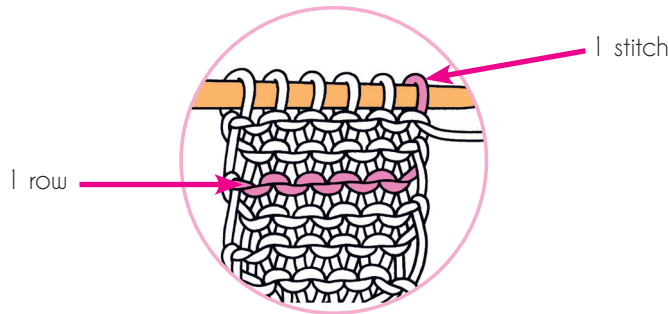

KNIT

Hold the needle with the cast-on stitches in your left hand with the yarn at the back of the work. Insert the right-hand needle from left to right in the first stitch, passing under the left-hand needle.



Wind the yarn around the right-hand needle passing under and over the tip and hold the yarn against the right-hand needle with your right hand.

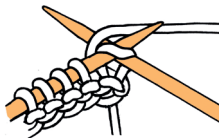

Insert the tip of the right-hand needle into the stitch on the left-hand needle and again over the left-hand needle. The loop thus formed on the right-hand needle is a knit stitch.



Let the loop drop off the left-hand needle and keep the new stitch on the right-hand needle.

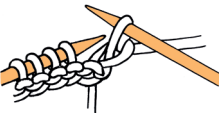

To knit a row, repeat steps 1 to 4 until all the stitches have passed from the left to the right-hand needle.

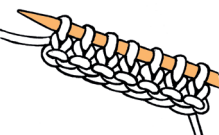

Turn the work, take the needle with the stitches in your left hand, and work the next row.

PURL

Hold the needle with the cast-on stitches in your left hand with the yarn in front of the work. Insert the right-hand needle from right to left in the first stitch on the left-hand needle.

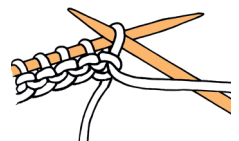

Wind the yarn around the right-hand needle passing over and under the tip and hold the yarn against the right-hand needle with your right hand.



Insert the tip of the right-hand needle into the stitch on the left-hand needle and again under the left-hand needle. The loop thus formed on the right-hand needle is a purl stitch.

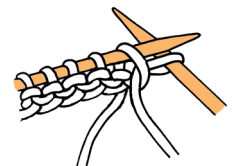

Let the loop drop off the left-hand needle and keep the new stitch on the right-hand needle.



To purl a row, repeat steps 1 to 4 until all the stitches have passed from the left to the right-hand needle.

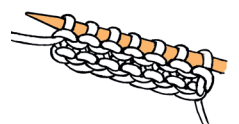

Turn the work, take the needle with the stitches in your left hand, and work the next row.

I DISCOVER
THE BASIC
STITCHES

Sorry? What
was that darling?
A restaurant?
Tonight?



GARTER STITCH



When you knit every row, the resulting pattern is called garter stitch.

STOCKING STITCH



Row 1 (right side) : knit.
Row 2 (wrong side) : purl.
Repeat these 2 rows.

REVERSE STOCKING STITCH



Row 1 (right side) : purl.
Row 2 (wrong side) : knit.
Repeat these 2 rows.



Seeing it live is even easier !
Find our video tutorials on
www.youtube.com/bergerefr
(in french)

BASIC KNITTING STITCHES

1/1 rib

Cast on an uneven number of stitches.

Row 1 : knit 1, purl 1, and repeat these 2 stitches to the last stitch, knit 1.

Row 2 and subsequent rows : purl over the purl stitches, knit over the knit stitches.

Repeat these 2 rows.

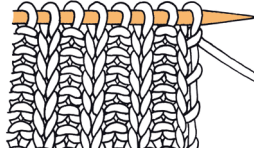

2/2 rib

Cast on a multiple of 4 stitches + 2 (e.g., 22 stitches).

Row 1 : knit 2, purl 2, and repeat to the last stitches, knit 2.

Row 2 and subsequent rows : purl over the purl stitches, knit over the knit stitches.

Repeat these 2 rows.

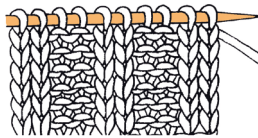

Seed or moss stitch

Cast on an uneven number of stitches.

Row 1 : knit 1, purl 1, repeat these 2 stitches.

Row 2 and subsequent rows : purl over knit stitches, knit over purl stitches.

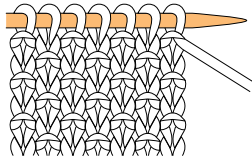

Corn stitch

Cast on an uneven number of stitches.

Row 1 : knit 1, purl 1, repeat these 2 stitches, ending with knit 1.

Row 2 : purl over purl stitches, knit over knit stitches.

Row 3 : purl over knit stitches, knit over purl stitches.

Row 4 : purl over purl stitches, knit over knit stitches.

Repeat these 4 rows.

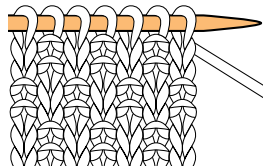

Yarn forward

By bringing the yarn forward you add a stitch and make an eyelet.

Bring the yarn in front of the work then over the right-hand needle.

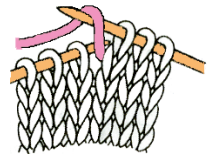

Work the next stitch on the left-hand needle. The yarn forward loop forms an extra stitch with a hold at its base on the right-hand needle.

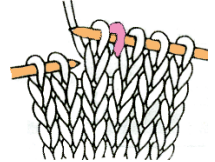

Next row : When you come to the yarn forward loop, purl it as you would any other stitch; you now have 1 extra stitch.

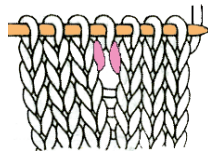

Knit 2 together

Put the right needle through the 2nd then the 1st stitch on the left hand needle.

Knit the 2 stitches together (wrap yarn around right hand needle and pull through the 2 stitches on the left needle).

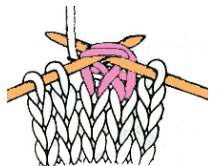
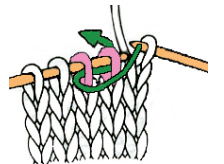

By knitting 2 stitches together you will have 1 less stitch on the needle..

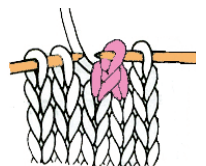

Slipped stitch

With the yarn at the back of the work, insert the right-hand needle into the next stitch from right to left, as if to purl. Slip the stitch on to the right-hand needle and continue working as given.

Next row : Purl the slipped stitch.

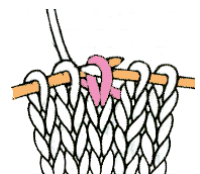

Single decrease

Slip a stitch on to the right-hand needle as if to knit.
Knit the next stitch.

Using the left-hand needle, pass the slipped stitch over the stitch you just worked.

After working a single decrease, you have 1 less stitch on the needle.

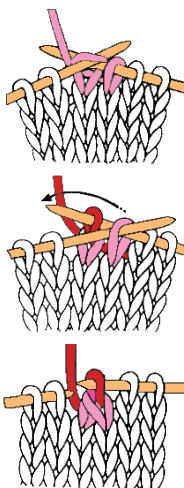

Double decrease

Slip a stitch on to the right-hand needle as if to knit.
Knit the next 2 stitches together.

Using the left-hand needle, pass the slipped stitch over the 2 stitches you just worked.

After working a double decrease, you have 2 fewer stitches on the needle.

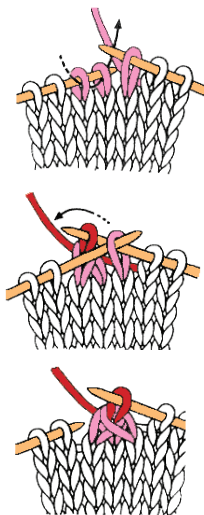

Twisted knit stitch

Knit the stitch, inserting the needle through the back loop to twist the new stitch.

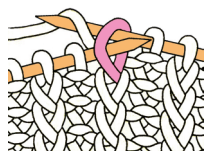

Twisted purl stitch

Purl the stitch, inserting the needle under the back loops to twist the new stitch.

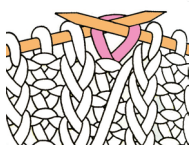

Nonstitch or suppressed stitch

Sometimes, the number of stitches varies from row to row in a pattern; the nonstitches or suppressed stitches are represented by black squares on the chart. When you follow the chart, do not try to work the black squares but go directly to the next square.

Working in reverse

When instructed on the front of a garment, for example a jacket, to work the other front in reverse. If you increased or decreased at the beginning of a right side row on the first front you must increase or decrease at the end of the right side row on the second front at the same measurement. The positions of the stitches used will also be reversed, if you ended with a ribbed section for a border on the first front you will start with the ribbed section on the second front. However the pattern should remain the same (do not reverse a cable twist for example).

Double decrease slip slip knit

Slip 2 stitches as if to knit. Knit 1.
Pass the 2 slipped stitches over the stitch just worked..

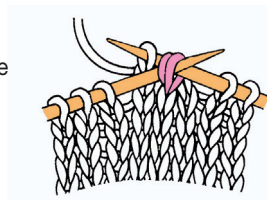

Raglan decreases

This method of decreasing is always used for Raglan sleeves. It forms a line of slanting stitches parallel with the seam. The decrease is worked with the right side facing, one or more stitches from the edge.

The example shows decreases 1 stitch from the edge :

At beginning of row, with right side facing, knit 1, slip 1, knit 1, pass slipped stitch over (See above).

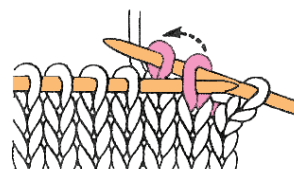

Continue the row as indicated. When 3 sts are left on the left-hand needle, knit the next 2 sts together (see knit 2 together, page 7), knit the last stitch.

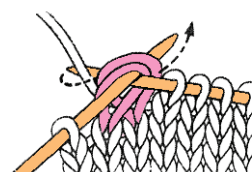

Increases within a row

When you need to increase a stitch in a row you will need to work twice into one stitch.

Put your right needle through the loop of the stitch below the current stitch on your left needle, knit into this stitch.

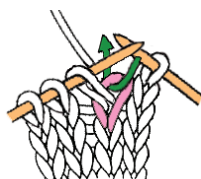

Work the stitch on your left needle as normal.

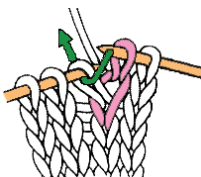

You will have one more stitch.

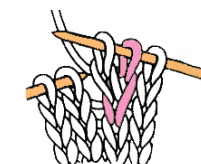

Increases 1 stitch in from edge of row

These increases are always done on the right side of work, 1 stitch in from the edge.

At the beginning of the row, on the right side of work, knit 1 stitch, put the right needle under the horizontal thread before the first stitch on left needle.



Put this strand onto the left needle.



Knit into the back of this loop to twist it.

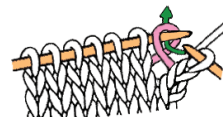

This prevents a gap forming at the bottom of the increased stitch. Continue along the row.

At the end of the row, on the right side of work, work until 1 stitch remains on left needle, pass right needle through the back of the horizontal thread between stitches and place on left needle.

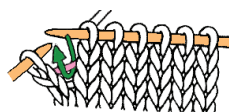

Knit this stitch as normal then knit last stitch.

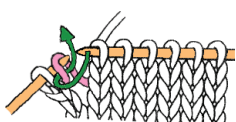

Increases of one stitch or more at end of work

Wrap yarn around the needle at the beginning of the row as many times as you need stitches. If you are increasing at each end you will also need to do at the end of the row.

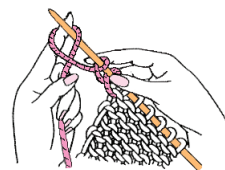

Work these stitches as knit or purl in the pattern required.

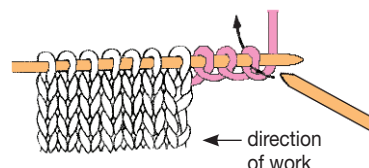

Stretch cast-on

Short Row Shaping Short rows are rows which are not worked in their entirety, this gives a curve to the work as more rows are completed on one side than the other. They can be used on just one side of work or both sides, creating a gentle slope instead of the stepped edge created by casting off a series of stitches.

When told to turn the work during the progress of a row you will not work the remaining stitches on the left hand needle.

To avoid creating a hole when you turn the work, after turning, with the yarn at the front of work (as if about to purl), slip the 1st stitch on the left hand needle onto the right hand needle as if to purl, then take yarn back to back of work (called a wrap) & work the remaining stitches as normal.

When you have finished the short row shaping and need to knit across the whole row you need to knit together the wrap & the next stitch. Take the wrapped stitch back over the top of next stitch then knit both together.

Stretch cast-on

Take a ball of yarn in a contrasting colour and cast on half the required number of stitches plus 1 extra.

For example : If the pattern tells you to cast on 45 stitches, using the contrasting yarn cast on $\frac{45 + 1}{2} = 23$ stitches.

Now, using the yarn you intend to work the pattern with, work as follows :

Row 1 : * knit 1, bring yarn forward under the needle, yarn over *. Repeat from * to *. End with knit 1.

Row 2 : Slip the first stitch as if to purl on to the right-hand needle, *pass yarn to back, knit 1 (= yarn forward loop from previous row), bring yarn forward, slip next stitch as if to purl *. Repeat from * to *.

Row 3 : * knit 1, yarn forward, slip 1 stitch as if to purl, pass yarn to back *. Repeat from * to *. End with knit 1. Continue working in 1/1 rib, beginning Row 1 with purl 1. After completing the ribbing, pull out the contrasting yarn.

Casting off stitches

1) To form armholes or collar

You must cast off stitches at the beginning of rows:

On the right side of work, slip 1 stitch onto the right needle as if to purl. Knit the following stitch.

Using the left needle pass the slipped stitch over the top of the 2nd stitch on the right hand needle. You have cast off 1 stitch.

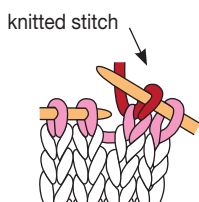

Knit the next stitch and pass stitch on right needle over the top, you have cast off a 2nd stitch. Repeat this step for the required number of stitches. On the following row, on the wrong side of work, cast off in the same way but work the stitches as purl stitches.

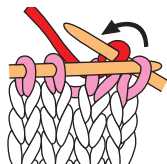

On the following row, cast off the next number of stitches indicated in the pattern to obtain a sloped edge.

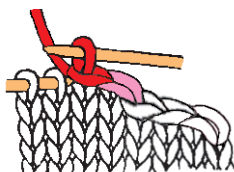
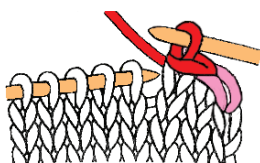

2) When work is complete, to cast off all stitches.

Start to cast off as for casting off at the beginning of row:

Slip the 1st stitch, knit the following stitch.

With the left needle, pass the slipped stitch over the top of the knitted stitch.

Knit the next stitch and with the left needle, pass the 1st stitch on needle over the top of the current stitch. One stitch remains on right needle.

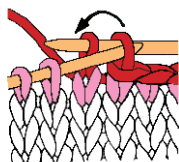

Repeat this sequence until all stitches from the left needle have been worked and only one stitch remains on right needle. Cut thread 10 cm from work and pull through remaining stitch using needle.

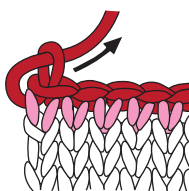

Small buttonholes

For a small buttonhole, one stitch is sufficient to make a buttonhole:

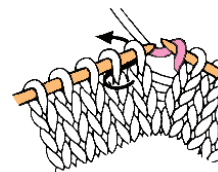

Yarn over needle, then knit 2 together. On the next row work the yarn over needle as normal.

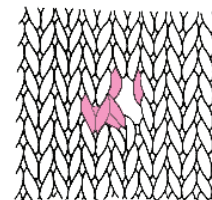

Buttonholes

1st row : Work to where the buttonhole should be, cast off the number of sts indicated in the pattern and work to end of row.

2nd row : Work to cast off sts, cast on the same number of sts as 1st row and work to end of row.

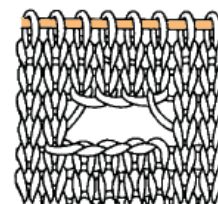

No-cut buttonholes

Using a sewing needle, pick up the horizontal strand of the stitch where you want to place the buttonhole, pull it up and attach it 2 rows higher with a few little stitches on the wrong side of the work. Repeat with the horizontal strand below the first strand, and attach it in the same way 2 rows down.

Pattern stitches

Instructions for pattern stitches are always given row by row, as well as in chart form, with each square on the chart representing 1 stitch and 1 row.

The accompanying legend explains the terms and matches the symbols to the stitches. The chart shows the right side of the work, it is not always possible, however, to include all the subtleties of a pattern stitch in a chart. For that reason, we advise you to always read the row-by-row instructions, even if you prefer to use a chart.

Knit over knit and purl over purl is an instruction often used for ribbing and pattern stitches.

Cables

It is easy to work narrow cables over 2 stitches :

Right cross 2 : Passing in front of the work, knit the 2nd st on the left-hand needle then knit the first stitch; slip both stitches on to the right-hand needle at once.

Left cross 2 : Passing behind the work, knit the 2nd st on the left-hand needle then knit the first stitch as usual; slip both stitches on to the right-hand needle at once.

A cable made up of 3 or more stitches requires the use of a cable needle.

Cable 4 left (front) :

Slip 2 stitches on to a cable needle in front of work, knit 2, then slip the 2 stitches from the cable needle on to the left-hand needle and knit 2.

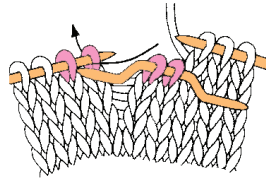

Cable 4 right (back) :

Slip 2 stitches on to a cable needle at back of work, knit 2, then slip the 2 stitches from the cable needle on to the left-hand needle and knit 2.

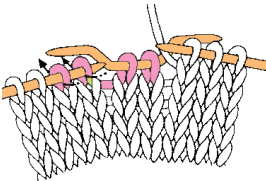

Picking up stitches

When the different sections of the garment are completed, you may need to pick up stitches at the edge of your work, for example on the collar or front borders

To pick up the stitches knit wise, put needle through the middle of each stitch on the last row and pick up the loop. When you are picking up stitches on rows where there are more rows than stitches required work through 2 or 3 rows then skip 1 row to obtain the number of stitches required in the pattern.

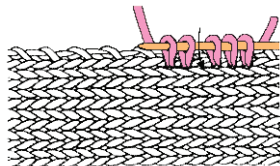
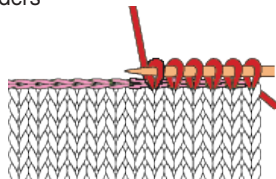

Backstitched seam

Place the 2 pieces right sides together. Thread a tapestry needle with the matching yarn, insert the needle through both thicknesses, matching stitch for stitch, and bring the needle out 2 rows further along.

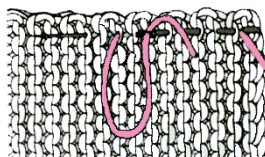

Grafting

This technique is widely used in European patterns, but is not so popular among UK and US knitters. When you have completed the sections, do not cast off, but leave the stitches on a spare needle.

Thread a tapestry needle with the matching yarn. Work with right side facing. Place the 2 spare needles together.

Insert the tapestry needle through the centre of the first stitch on the front needle as if to purl (leave the stitch on the needle),

– and bring the tapestry needle out at the centre of the first stitch on the back needle as if to knit (leave the stitch on the needle),

*bring the tapestry needle through the centre of the first stitch on the front needle again as if to knit and slip off the stitch,

– Insert the tapestry needle through the centre of the next stitch on the front needle as if to purl (leave the stitch on the needle),

– bring the tapestry needle out at the center of the next (first) stitch on the back needle again as if to purl and slip off the stitch,

– Insert the tapestry needle through the centre of the next stitch on the back needle as if to knit (leave the stitch on the needle)*, maintaining an even tension. Repeat the movement until the seam is complete.

Work all the free stitches into the seam one by one and let the stitches drop off the spare needles as they are grafted together.

The finished seam will look identical to a row of knitting.

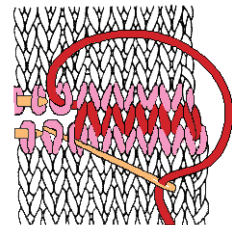
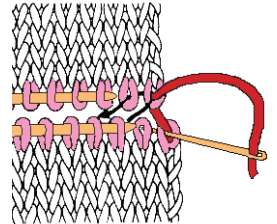

Invisible seam

Following the sketch, working with the 2 pieces to be joined, pick up the horizontal thread between the first and second stitches and pull firmly to bring the edges together and make the join invisible. If the edge is very uneven, work the thread between the second and third stitches.

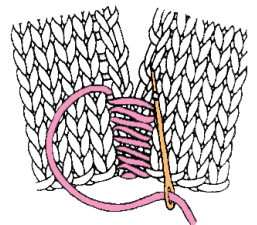

You may also use an invisible seam to join at the shoulder. In that case, pick up the 2 upright strands of a stitch 1 row in from the edge.

Fair Isle

Fair Isle and contrasting colour patterns.

These patterns are worked in stocking stitch using several colours to make a design shown on a chart.]

Each square on the chart represents 1 stitch and 1 row. A legend accompanying the chart indicates the colours. Read the chart beginning at the bottom row, from right to left for the right side of the work, and from left to right for the wrong side rows.

KNITTED PATTERNS

Various techniques are used according to the complexity of the pattern.

- When the motifs of the design are small and close together, you may let the yarn not in use run loosely at the back of the work. Make sure that you don't pull the yarn taut or it will pucker the pattern.
- When the motifs are far apart or very wide, pass the yarn not in use behind the work attaching it along with the one that is in use : hold the yarn not in use in your left hand, then work a stitch passing the right-hand needle under that yarn but taking care not to actually knit the yarn. Repeat this movement every other stitch.
- When the motifs are very large or use several colours, do not try to pass the yarn at the back of the work. Instead, use several balls of each colour, as needed, using the intarsia technique. Each time you change yarn colour, make sure that you twist the yarns loosely at the back of the work to avoid forming holes in the texture.

In all three cases, take care to work evenly, especially where the colours change and stitches tend to be loose.

EMBROIDERED PATTERNS

Embroidery can be used to advantage instead of knitted patterns when the motifs are made up of relatively few stitches.

This technique avoids the problems of disposing of extra yarns at the back of the work. For embroidery, form open chain stitch with a tapestry needle, working from right to left.

Bring the needle from wrong side to right side at the base of the first stitch, insert the needle from right to left under both strands of the stitch above the one being worked (see sketch no. 1), then insert the needle again at the base of the stitch being worked and bring it out at the base of the next stitch (see sketch no. 2).

Use this technique to embroider the number of stitches indicated. After the last stitch, bring the needle out at the base of the row above. Turn the work to start again from right to left.

Sketch no 1

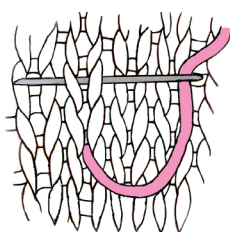

Sketch no 2

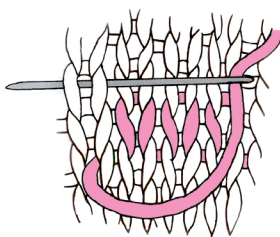

Grafting a border

When the border is finished, work a few rows of stocking stitch using a contrasting yarn.

Take the work off the needle and press the stocking stitch section with a warm iron under a damp cloth to prevent it from unraveling. Pin the border to the finished garment, matching the stitches. Unravel all but the last row of stocking stitch. Now graft the stitches, waving the tapestry needle in and out, and unravel the last row of stocking stitch as you go. Bring the needle from back to front through the centre of the second stitch, work a back stitch into the first stitch and bring the needle out again at the centre of the third stitch; now work a backstitch again into the second stitch and continue thus with backstitching as far as the last stitch.

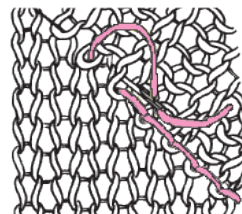

Chainstitch shoulder seam

CHAINSTITCH SHOULDER SEAMS

or 3 needles cast off or 3 needles bind off

Leave the remaining shoulder stitches on a spare needles. Place back and front with wrong sides together.

Using a third needle, knit together the first stitch from the front needle with the first from the back needle, and repeat with the second stitch from each needle. You now have 2 stitches on the right-hand needle.

Pass the first stitch over the second, as in casting off. Continue thus until you have cast off all the shoulder stitches. The result is a chain that shows on the right side and a shoulder seam that will not go out of shape. To obtain an invisible seam on the right side, place back and front with right sides together.



BASIC CROCHET STITCHES

Chain stitch (ch or ch st)

The first stitch in crochet. Make a loop. Insert the hook in the loop. * Pass the hook under the yarn for a yarn over (yo), and pull the yo through the loop = 1 ch st. Rep from * to work as many ch sts as needed.

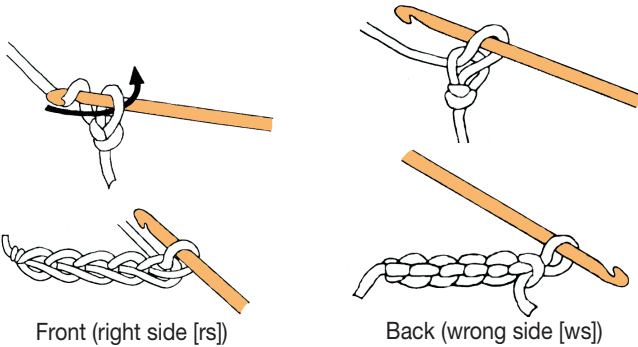

Slit stitch (sl st)

Insert the hook into a stitch, yo and pull through the loop on the hook in a single movement.

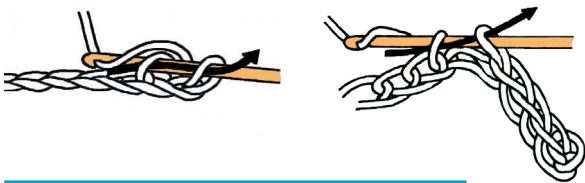

Single Crochet (

UK: Double Crochet) = sc (uk: dc)

Insert the hook into a stitch, yo and draw up loop, yo and through both loops on hook.

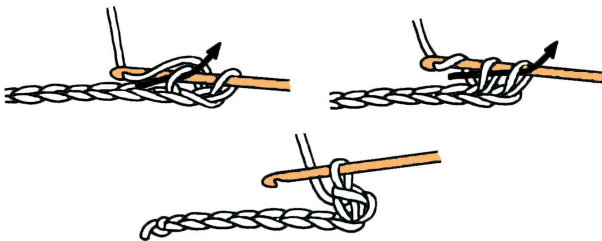

Crab Stitch (sc (uk: dc) worked from left to right)

Beg at left edge: * insert hook into a stitch, yo and draw up lp, yo and through both lps on hook *, rep from * to *, inserting hook into preceding st..

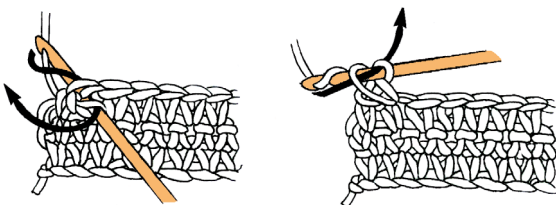

Half Double Crochet

(UK: Half Treble) = hdc (uk: half tr)

Yo, insert the hook into a stitch, yo and draw up loop, yo and through all 3 loops.

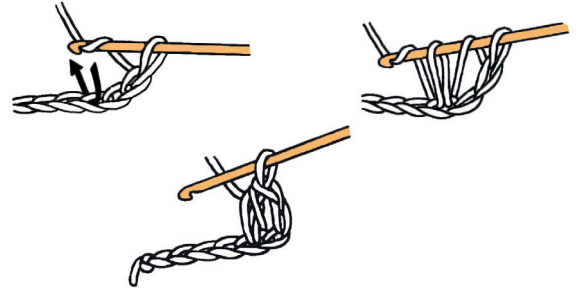

Double Crochet

(UK: Treble) = dc (uk: tr)

Yo, insert the hook into a st, yo and draw up loop, yo and through first 2 loops on hook, yo and through remaining 2 loops.

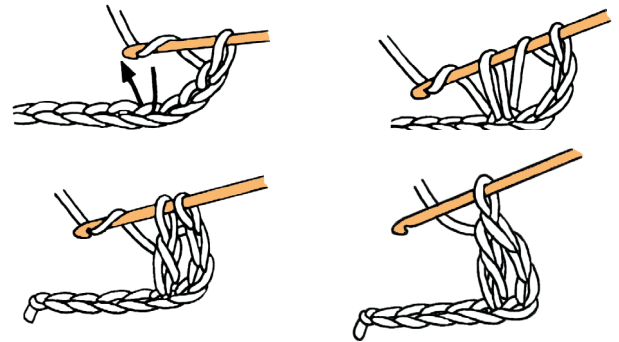

Treble (UK: Double Treble) = tr (uk: dbl tr)

Yo twice, insert the hook into a stitch, yo and draw up loop, yo and through first 2 loops on hook, yo and through 2 loops on hook, yo and through remaining 2 loops.

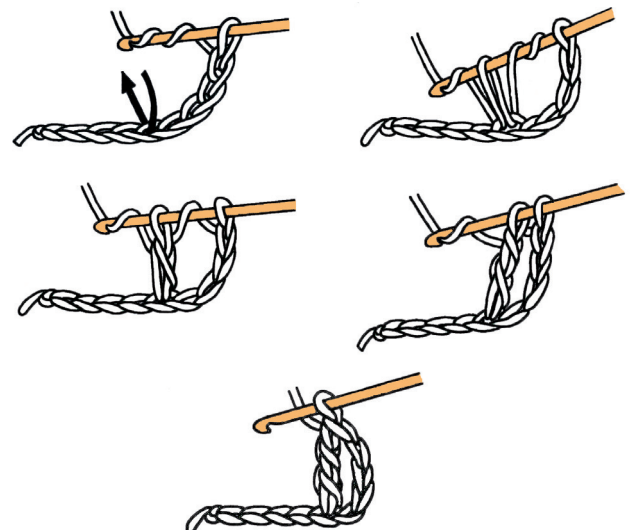

Double Treble

(UK: Triple Treble) = dbl tr (uk: tr tr)

Yo 3 times, insert the hook in a stitch, yo and draw up loop, yo and through first 2 loops on hook, yo and through 2 loops on hook, yo and through 2 loops on hook, yo and through remaining 2 loops.

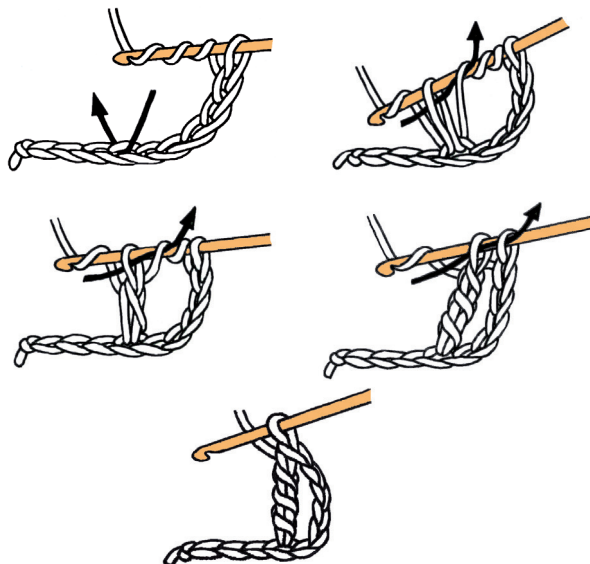

Beginning with a round

Wind the yarn around the tip of your index finger, slip the hook through the loop, yo and draw up lp, yo and through the loop as shown, then work as many dc as indicated. To end the first round, work a sl st over the first dc and pull gently but firmly on the end of yarn to close up the initial ring..

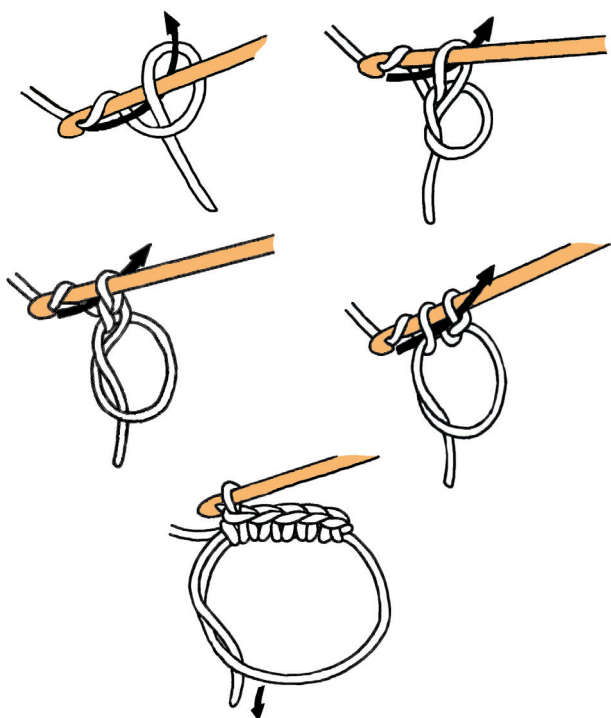

2 Single Crochet Together (UK: 2 Double Crochet Together) = 2 sc tog (uk: 2 dc tog)

Leaving last loop of each st on the hook, work incomplete sc as follows: Insert hook into a st, yo and draw up loop, insert hook into next st, yo and draw up loop, yo and through all remaining 3 loops.

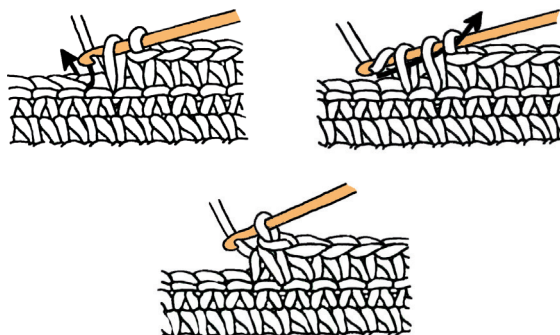

3 single crochets together (3 sc tog) [3 double crochets together : 3 dc tog (UK)]

Leaving last loop of each stitch on the hook, work incomplete sc as follows; insert hook in a stitch, yo and draw up loop, insert hook in next stitch, yo and draw up loop, insert hook in next stitch, yo and draw up loop, yo and through all remaining 4 loops at once.

2 Double Crochets Together

(UK: 2 Trebles Together) = 2 dc tog (uk: 2 tr tog)

Leaving last loop of each st on the hook, work incomplete dc as follows : yo, insert the hook into a st, yo and draw up loop, yo and through first 2 loops on hook, yo, insert hook into next st, yo and draw up loop, yo and through first 2 loops, yo * and through all 3 remaining loops.



3 Double Crochets Together (UK: 3 Trebles Together) = 3 dc tog (uk: 3 tr tog)

As for 2 dc tog as far as *, then insert hook into next st, yo and draw up loop, yo and through 2 loops on hook, yo and through all 4 remaining loops.

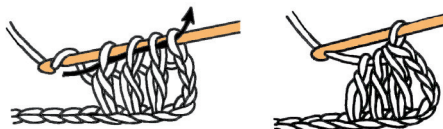

2 or 3 Double Crochets Together (UK: 2 or 3 Trebles Together) = 2 or 3 dc tog (uk: 2 or 3)

As for dc tog (tr tog), but beg by working yo twice.

| EMBROIDERY STITCHES |

Stem stitch

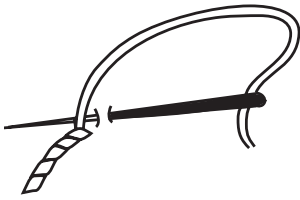

Backstitch



Bullion stitch

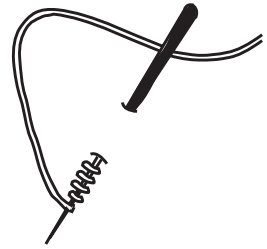

Running stitch

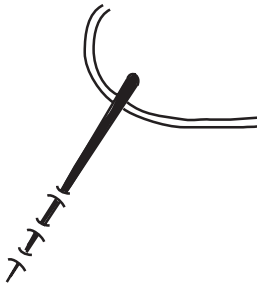

Chain stitch

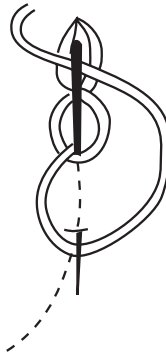

Straight stitch

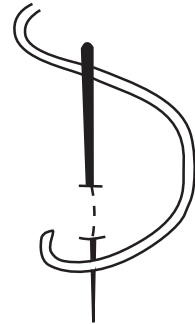

Blanket stitch

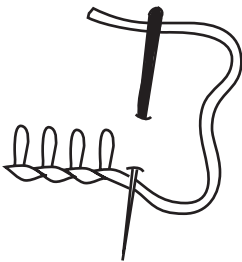

Feather stitch



French knot

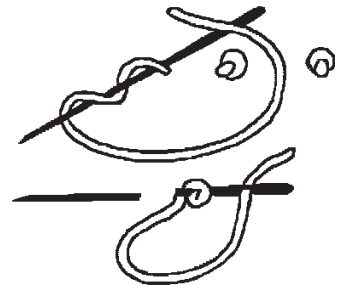

Lazy daisy stitch

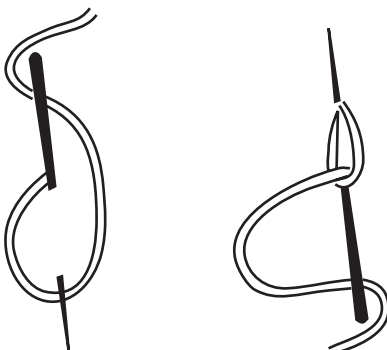

Cross stitch

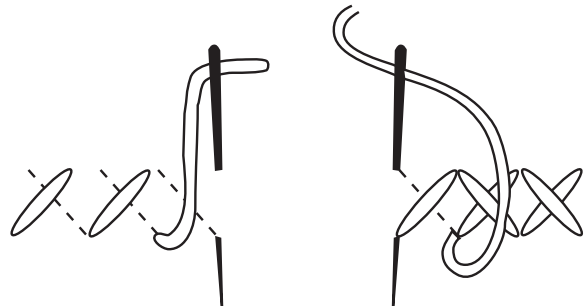

CABLED JACKET



Quality:
FILOMÈCHE

Needles:
6.0 & 7.0 mm
1 cable needle

Accessories:
5 brown buttons Ø 28 mm ref. 30133 (pk of 6)
Navy blue sewing thread (not sold)

Sizes		S	M	L	XL
Quality FILOMÈCHE		Number of balls			
Canard	54608	14	15	16	18

● Abbreviations

Right cross = CR

4CR: Slip 2 sts to CN at back of work, k the next 2 sts, then k the 2 sts from CN.

● Stitches used

2/2 RIB, using 6.0 mm and 7.0 mm needles.

CABLE, using 7.0 mm needles. Worked over 4 sts.

Row 1 (RS): k.

Row 2 and all even rows: p.

Row 3: k.

Row 5: 4CR.

Row 7, 9 and 11: k.

After Row 12, rep from Row 5.

STOCKING STITCH (St st), using 7.0 mm needles.

● Tension/Gauge

To achieve a good result, it is essential to make a tension square (See "Check Your Tension" instructions at beginning of book).

14 sts and 17 rows in 2/2 Rib using 7.0 mm needles = 10 cm (4 in) square

● To make

BACK:

Using 6.0 mm needles, cast on **68-74-80-86** sts.

Work in 2/2 Rib for **6 cm (2¼ in) [12 rows]** starting and ending with:

S: k3.

M: k2.

L: p3.

XL: p2.

Change to 7.0 mm needles and work as foll:

– **9-12-15-18** sts in the continuation of the 2/2 Rib,
– **4** Cable sts and inc 2 sts evenly spaced across 1st row (see placement on chart), * **10** sts in 2/2 Rib starting with p2, **4** Cable sts and inc 2 sts evenly spaced across 1st row *, work 4 times total from * to *,

– **9-12-15-18** sts in the continuation of the 2/2 Rib.

You have **78-84-90-96** sts.

Work even until piece measures **42-43-44-44** cm (**16½-17-17½-17½** in) [**74-76-78-78** rows] total.

Armholes:

Cast off at the beginning of every row as foll:

S: 2 sts 4 times, 1 st 8 times.

M: 3 sts twice, 2 sts twice, 1 st 8 times.

L: 3 sts twice, 2 sts 4 times, 1 st 6 times.

XL: 3 sts twice, 2 sts 4 times, 1 st 8 times.

Cont and work even on the rem **62-66-70-74** sts until piece measures **64-66-68-70** cm (**25¼-26-26¾-27½** in) [**110-114-118-122** rows] total.

Shoulders and neck:

For shoulders cast off at the beginning of every row as foll:

S: 6 sts 4 times, 7 sts twice,

M: 6 sts twice, 7 sts 4 times,

L: 7 sts 4 times, 8 sts twice,

XL: 7 sts twice, 8 sts 4 times,

at the same time when working 1st shoulder dec, **for neck** cast off the **20-22-22-24** center sts. Cont each side separately and cast off on neck side: 2 sts once.

LEFT FRONT:

Using 6.0 mm needles, cast on **32-35-38-41** sts.

Work in 2/2 Rib for **6 cm (2¼ in) [12 rows]** starting as for back.

Change to 7.0 mm needles and work as foll:

– **9-12-15-18** sts in the continuation of the 2/2 Rib,

– **4** Cable sts and inc 2 sts evenly spaced across 1st row, **10** sts in 2/2 Rib starting with p2, **4** Cable sts and inc 2 sts evenly spaced across 1st row,

– **9** sts in the continuation of the 2/2 Rib.

You have **36-39-42-45** sts.

Armhole:

Cast off on right edge as for back.

Then cont on the rem **28-30-32-34** sts until piece measures **58-60-62-64** cm (**22¾-23½-24½-25¼** in) [**100-104-108-112** rows] total.

Neck:

Cast off on left edge every 2nd row: **4-5-5-6** sts once, 2 sts once, 1 st 3 times.

Shoulder:

Cast off on right edge as for back.

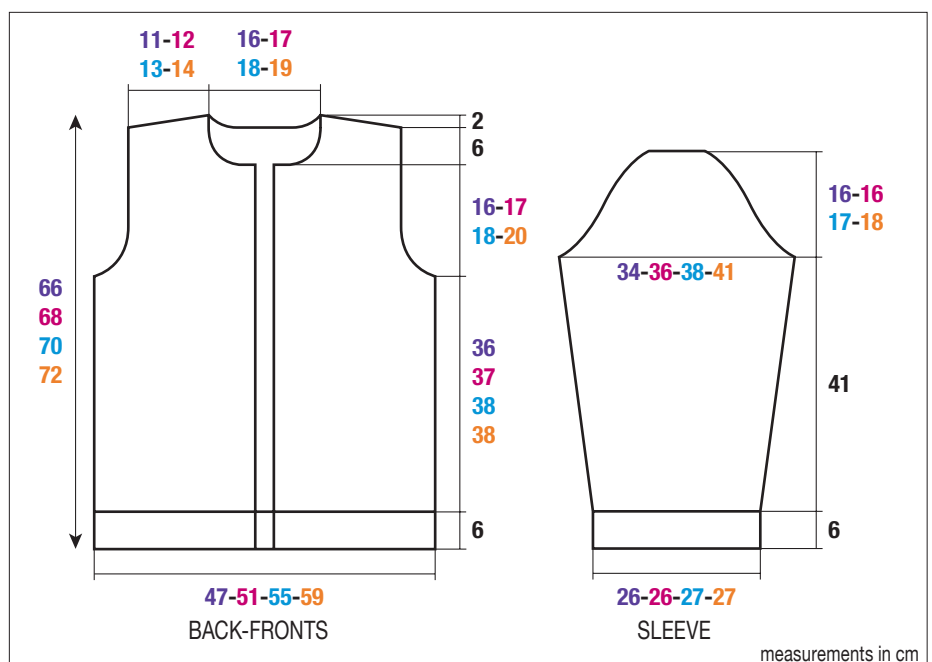

RIGHT FRONT:

Using 6.0 mm needles, cast on **32-35-38-41** sts.

Work in 2/2 Rib for **6 cm (2¼ in) [12 rows]** starting for all sizes with k3.

Change to 7.0 mm needles and work as foll:

- **9** sts in the continuation of the 2/2 Rib,
- **4** Cable sts and inc 2 sts evenly spaced across 1st row, **10** sts in 2/2 Rib starting with p2, **4** Cable sts and inc 2 sts evenly spaced across 1st row,
- **9-12-15-18** sts in the continuation of the 2/2 Rib.

You have **36-39-42-45** sts.

Armhole:

Cast off on left edge as for back.

Then cont on the rem **28-30-32-34** sts.

Neck:

Cast off on right edge as for left front.

Shoulder:

Cast off on left edge as for back.

SLEEVES:

Using 6.0 mm needles, cast on **38-38-40-40** sts.

Work in 2/2 Rib for **6 cm (2¼ in) [12 rows]** starting and ending with:

S and M: p2.

L and XL: k1.

Change to 7.0 mm needles and work as foll:

- **18-18-20-20** sts in the continuation of the 2/2 Rib,
- **4** Cable sts and inc 2 sts evenly spaced across 1st row,
- **18-18-20-20** sts in the continuation of the 2/2 Rib.

You have **40-40-42-42** sts.

Work even until piece measures **12 cm (4¾ in) [22 rows]** total.

Inc at each end, 1 st in from edge:

S: 1 st 6 times every 10th row.

M: 1 st twice every 10th row, 1 st 5 times every 8th row.

L: 1 st 6 times every 8th row, 1 st twice every 6th row.

XL: 1 st 10 times every 6th row.

Cont and work even on the **52-54-58-62** sts obtained until piece measures **46 cm (18 in) [80 rows]** total.

Cont and work as foll until piece measures **47 cm (18½ in) [82 rows]** total: **6-6-7-7** sts in St st, cont row as established until **6-6-7-7** sts rem on left needle and k those sts.

Top of sleeve:

Cast off **2-2-3-3** sts at the beg of the next 2 rows.

Then dec as foll at each end, 3 sts in from edge, starting on 1st row then every 2nd row:

S: 2 sts once, 1 st 11 times, 2 sts once and the rem 18 sts.

M: 2 sts once, 1 st 10 times, 2 sts twice and the rem 18 sts.

L: 2 sts once, 1 st 11 times, 2 sts twice and the rem 18 sts.

XL: 2 sts once, 1 st 11 times, 2 sts 3 times and the rem 18 sts.

To dec 2 sts, 3 sts in from edge: k3, k3 tog, cont row until 6 sts rem on left needle, k2tog, sl1, pss0, k3.

To dec 1 st, 3 sts in from edge: k3, k2 tog, cont row until 5 sts rem on left needle, k1, sl 1, pss0, k3.

COLLAR:

Using 6.0 mm needles, cast on **56-60-64-68** sts.

Work in 2/2 Rib for **16 cm (6¼ in)** starting and ending with k3, and leave all sts on hold.

EDGINGS:

Edging 1: Using 6.0 mm needles, cast on **92-96-100-104** sts.

Work in 2/2 Rib starting and ending with k3.

On **5th** row, work **4** sts, * cast off **1** st (= 1 buttonhole), work **20-21-22-23** sts *, rep 3 more times from * to *, then cast off **1** st and work row to end.

Next row: cast on 1 extra st to replace each cast-off st.

Work even for **2** rows on all sts and leave all sts on hold.

Edging 2: Using 6.0 mm needles, cast on **92-96-100-104** sts.

Work in 2/2 Rib for **8** rows starting and ending with k3, and leave all sts on hold.

FINISHING:

Join shoulder seams.

Collar: Graft collar to neck edge (see Grafting instructions). Fold it in half to WS and hem in place.

Edgings: Graft Edging 1 to edge of left front up to top of collar, then graft Edging 2 to edge of right front (see Grafting a border instructions).

Sew sleeves into position.

Sew sleeve seams and sides of jacket.

Attach buttons.

Secure and weave in ends.

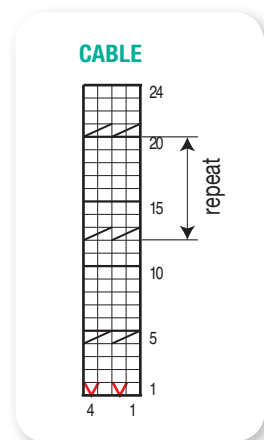

- = 1 St st
- ▣ = 1 increase
- ▨ = 4CR

SHAWL COLLAR JACKET



Quality:
FILOMÈCHE

Needles:
10.0 & 12.0 mm
Crochet hook sizes:
6.0 mm

Accessories:
3 ecru nacre toggle buttons 50 mm ref. 67695 (pk of 2)

Sizes	S	M	L	XL	XXL
Quality FILOMÈCHE	Number of balls				
Opale (A) 54612	8	9	10	11	12
Ecru (B) 54586	7	7	8	9	9
Canard (C) 54608	5	5	6	6	7

Stitches used

Jacket is entirely made holding 2 strands tog (see stripes).

Stripes, work as foll:

- 2 rows using 2 strands B,
- 2 rows using 1 strand B + 1 strand A,
- * 1 row using 2 strands A,
- 1 row using 1 strand A + 1 strand C,
- 2 rows using 2 strands C,
- 1 row using 1 strand C + 1 strand A,
- 5 rows using 2 strands A,
- 1 row using 1 strand A + 1 strand B,
- 1 row using 1 strand B + 1 strand C,
- 1 row using 2 strands C,
- 1 row using 1 strand C + 1 strand B,
- 1 row using 2 strands B,
- 1 row using 1 strand B + 1 strand A,
- 1 row using 2 strands B,
- 1 row using 1 strand B + 1 strand A,
- 1 row using 2 strands A,
- 1 row using 1 strand A + 1 strand B,
- 1 row using 1 strand B + 1 strand C,
- 1 row using 2 strands B,
- 1 row using 1 strand B + 1 strand A *,
- rep from * to *.

1/1 RIB, using 10.0 mm needles.

STOCKING STITCH (St st), using 12.0 mm needles.

Crochet basics: See "Crochet: Stitches/Techniques"

Tension/Gauge

To achieve a good result, it is essential to make a tension square (See "Check Your Tension" instructions at beginning of book).

8 sts and 12 rows in St st using 2 strands A = 10 cm (4 in) square

To make

BACK:

Using 10.0 mm needles and B, cast on **43-45-49-53-57** sts.

Work in stripes as foll:

- in 1/1 Rib for 4 cm (1½ in) [6 rows], but on last row **for size M only** inc 1 st (= **43-46-49-53-57** sts),
- then using 12.0 mm needles, work even in St st until piece measures **48-49-49-50-51** cm (**19-19¼-19¼-19¼-20** in) [**58-60-60-62-64** rows] total.

Armholes:

Cast off 2 sts at the beg of the next 2 rows.

Then cont and work even on the rem **39-42-45-49-53** sts until piece measures **66-68-70-72-74** cm (**26-26¼-27½-28¼-29** in) [**80-84-86-88-92** rows] total.

Neck:

Cast off the **13-12-13-13-13** center sts, and cont each side separately until piece measures **66-68-70-72-74** cm (**26-26¼-27½-28¼-29** in) [**82-86-88-90-94** rows] total.

Shoulders:

Leave the rem **13-15-16-18-20** sts on hold.

LEFT FRONT:

Using 10.0 mm needles and B, cast on **15-17-17-19-21** sts.

Work in stripes as foll:

- in 1/1 Rib for 4 cm (1½ in) [6 rows], but on last row, **for sizes L - XL and XXL** inc 1 st (= **15-17-18-20-22** sts),
- then using 12.0 mm needles, work even in St st until piece measures **48-49-49-50-51** cm (**19-19¼-19¼-19¼-20** in) [**58-60-60-62-64** rows] total.

Armhole:

Cast off 2 sts on right edge.

Cont and work even on the rem **13-15-16-18-20** sts until piece measures **68-70-72-74-76** cm (**26¼-27½-28¼-29-30** in) [**82-86-88-90-94** rows] total.

Shoulder:

Leave the rem **13-15-16-18-20** sts on hold.

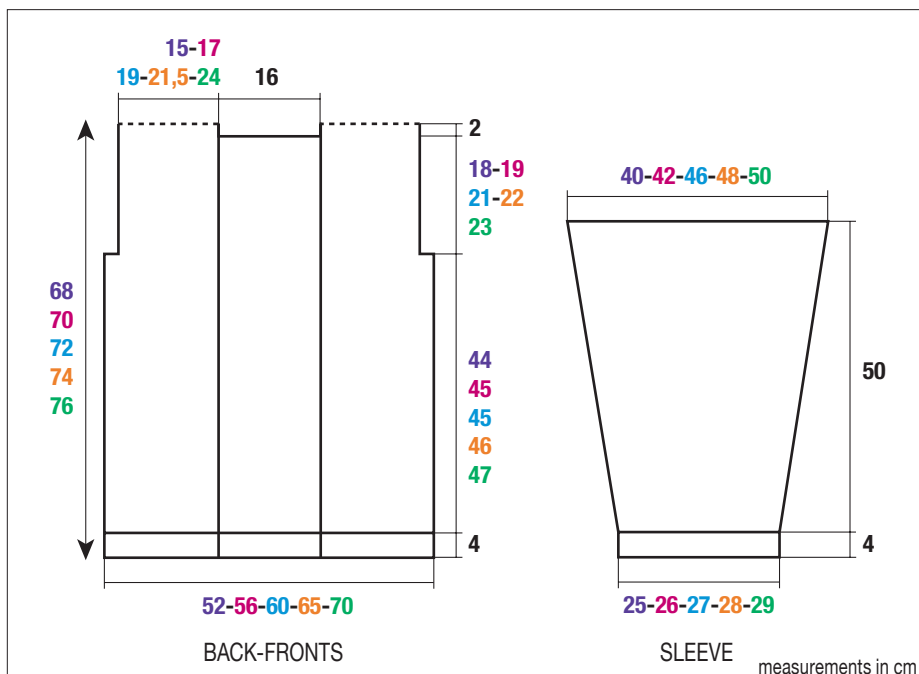

RIGHT FRONT:

Using 10.0 mm needles and B, cast on **15-17-17-19-21** sts.

Work in **stripes** as foll:

- in 1/1 Rib for **4 cm (1½ in) [6 rows]**, **but** on last row, **for sizes L - XL and XXL** inc 1 st (= **15-17-18-20-22** sts),
- then using 12.0 mm needles, work even in St st until piece measures **48-49-49-50-51 cm (19-19¼-19¼-20 in) [58-60-60-62-64 rows]** total.

Armhole:

Cast off 2 sts on left edge.

Cont and work even on the rem **13-15-16-18-20** sts until piece measures **68-70-72-74-76 cm (26¾-27½-28¼-29-30 in) [82-86-88-90-94 rows]** total.

Shoulder:

Leave the rem **13-15-16-18-20** sts on hold.

SLEEVES:

Using 10.0 mm needles and B, cast on **21-23-23-25-25** sts.

Work in **stripes** as foll:

- in 1/1 Rib for **4 cm (1½ in) [6 rows]**, **but** on last row, **for size S** inc 1 st ; **for size XL** dec 1 st (= **22-23-23-24-25** sts),
- then using 12.0 mm needles, work even in St st until piece measures **11 cm (4¼ in) [14 rows]** total.

Inc at each end as foll, 2 sts in from edge:

S and M: 1 st 6 times every 8th row.

L and XL: 1 st 8 times every 6th row.

XXL: 1 st 6 times every 6th row, 1 st 3 times every 4th row.

Cont and work even on the **34-35-39-40-43** sts obtained until piece measures **54 cm (21¼ in) [66 rows]** total.

Top of sleeve:

Cast off all sts.

EDGINGS:

Edging 1:

Using 10.0 mm needles and B, cast on **72-74-76-78-80** sts.

Work in **striped** 1/1 Rib for **20 rows** starting with k2, and leave all sts on hold.

Edging 2:

Using 10.0 mm needles and B, cast on **72-74-76-78-80** sts.

Work in **striped** 1/1 Rib for **20 rows** starting with p1 and ending with k2, and leave all sts on hold.

FINISHING:

Join shoulders on WS using the 3 needle bind off method (See "Knitting: Stitches/Techniques/Tips").

Graft Edging 1 to edge of left front up to center of back neck, and Edging 2 to edge of right front up to center of back neck. Join both edgings, with a folded edge of 8 cm (3 in).

Sew top of sleeves to vertical part of armholes.

Sew sleeve seams and sides of jacket.

Frog closures (3):

Part with loop:

Using 2 strands B and 6.0 mm crochet hook, make a chain of **20** chain sts.

To shape loop: work **1** sl st in the **10th** chain and end with **10** chain sts. Fasten off.

Part with toggle button: Thread 2 strands B through the holes of a button. Then, using 6.0 mm crochet hook work as foll:

- Make a chain of 10 chain sts before the button.
- Push the toggle button close to the last chain worked.

- Work 1 sl st in the 10th chain and pull tight.

- Work another 10 chain sts and fasten off.

Attach frog closures in place (see placement on diagram).

Secure and weave in ends.

DIAGRAM

 and  = frog closure

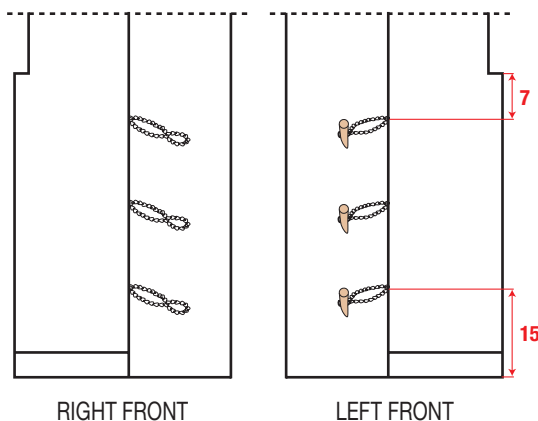

ROUND COLLAR SWEATER



Quality: **FILOMÈCHE**
Needles: **6.0 & 7.0 mm**

Sizes		S	M	L	XL	XXL
Quality FILOMÈCHE		Number of balls				
Ecru	54586	13	14	15	17	18

Stitches used

1/1 RIB, using 6.0 mm needles.

Row 1 : *k1, p1*, rep from * to *.

Row 2 : k over k, p over p.

SEED STITCH (Seed st), using 7.0 mm needles.

Row 1 : *k1, p1*, rep from * to *.

Row 2 : p over k, k over p.

Tension/Gauge

To achieve a good result, it is essential to make a tension square (See "Check Your Tension" instructions at beginning of book).

13 sts and 21 rows in Seed st = 10 cm (4 in) square

To make

BACK:

Using 6.0 mm needles, cast on **69-75-81-87-95** sts.

Work in 1/1 Rib for **9 cm (3½ in) [18 rows]**, but on last row, dec **4-6-6-6-8** sts evenly spaced.

Change to 7.0 mm needles and work in Seed st on the remaining **65-69-75-81-87** sts until piece measures **45-46-46-47-48 cm (17¾-18-18-18½-19 in) [94-96-96-98-100 rows]** total.

Armholes:

Cast off **3** sts at each end.

Continue even on the remaining **59-63-69-75-81** sts until piece measures **64-66-68-70-72 cm (25¼-26-26¾-27½-28¼ in) [134-138-142-146-150 rows]** total.

Shoulders and neck:

Cast off at the beginning of every row as follows:

S: 6 sts 4 times and the remaining 35 sts (= 6 sts at each end for shoulders and 23 sts for neck).

M: 6 sts 4 times and the remaining 39 sts (= 7 sts at each end for shoulders and 25 sts for neck).

L: 7 sts 4 times and the remaining 41 sts (= 8 sts at each end for shoulders and 25 sts for neck).

XL: 8 sts 4 times and the remaining 43 sts (= 8 sts at each end for shoulders and 27 sts for neck).

XXL: 8 sts twice, 9 sts twice and the remaining 47 sts (= 9 sts at each end for shoulders and 29 sts for neck).

FRONT:

Start as for back.

Armholes:

Cast off as for back.

Then continue on the remaining **59-63-69-75-81** sts until piece measures **59-61-63-65-67 cm (23¼-24-24¾-25½-26¼ in) [124-128-132-136-140 rows]** total.

Neck:

Cast off the **11-13-13-15-17** center sts.

Then continue each side separately and cast off on neck side every 2nd row: 2 sts twice, 1 st twice.

Work even until piece measures **64-66-68-70-72 cm (25¼-26-26¾-27½-28¼ in) [134-138-142-146-150 rows]** total.

Shoulders:

Cast off at the beginning of every row as follows:

S: 6 sts 6 times.

M: 6 sts 4 times, 7 sts twice.

L: 7 sts 4 times, 8 sts twice.

XL: 8 sts 6 times.

XXL: 8 sts twice, 9 sts 4 times.

SLEEVES:

Using 6.0 mm needles, cast on **31-33-35-35-37** sts.

Work in 1/1 Rib for **5 cm (2 in) [10 rows]**.

Change to 7.0 mm needles and work in Seed st until piece measures **11 cm (4¼ in) [22 rows]** total.

Increase at each end, 1 st in from edge:

S: 1 st 5 times every 10th row, 1 st 5 times every 8th row.

M: 1 st 11 times every 8th row.

L: 1 st 9 times every 8th row, 1 st 3 times every 6th row.

XL: 1 st 6 times every 8th row, 1 st 7 times every 6th row.

XXL: 1 st 3 times every 8th row, 1 st 11 times every 6th row.

Continue and work even on the **51-55-59-61-65** sts obtained until piece measures **56 cm (22 in) [118 rows]** total.

Top of sleeve:

Cast off all sts.

COLLAR:

Using 6.0 mm needles, cast on **77-81-83-85-89** sts.

Work in 1/1 Rib for **4 rows** and leave all sts on hold.

FINISHING:

Join the **18-19-22-24-26** sts of shoulders.

Graft collar to neck edge (see Grafting instructions).

Join the shorter ends.

Sew top of sleeves to vertical section of armholes.

Sew sleeve seams and sides of sweater.

Secure and weave in ends.

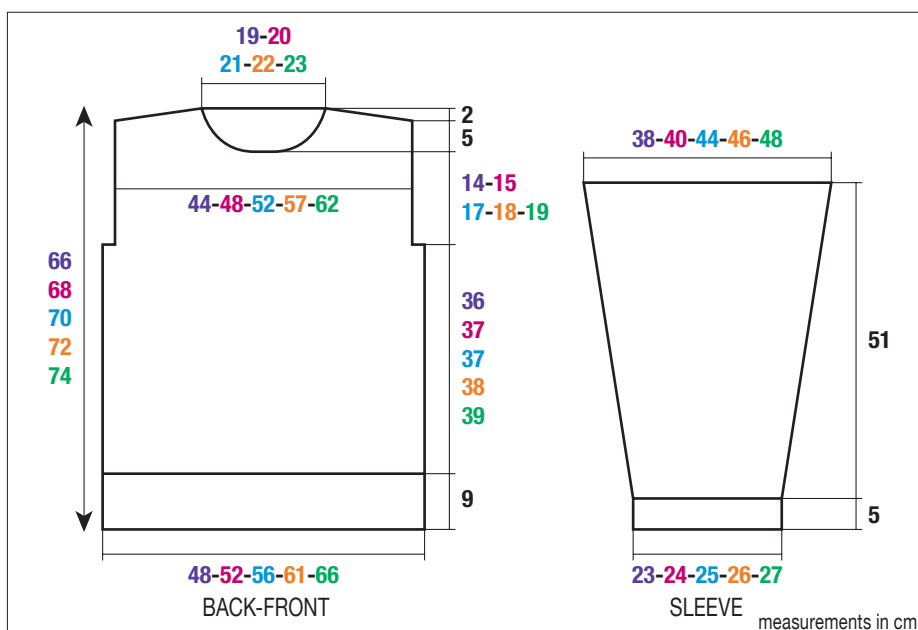

FAIR ISLE YOKE SWEATER



Quality:
FILOMÈCHE

Needles:
6.0 & 7.0 mm

Sizes		S	M	L	XL
Quality FILOMÈCHE		Number of balls			
Ecru (A)	54586	8	9	10	11
Pépîte (B)	54606	3	3	3	3
Varech (C)	54601	1	1	1	1

Stitches used

1/1 RIB, a using 6.0 mm needles

STOCKING STITCH (St st), using 7.0 mm needles.

FAIR ISLE, using 7.0 mm needles. Foll charts according to size made.

Tension/Gauge

To achieve a good result, it is essential to make a tension square (See "Check Your Tension" instructions at beginning of book).

13 sts and 17 rows in St st = 10 cm (4 in) square

14 sts and 15 rows in Fair Isle = 10 cm (4 in) square

To make

BACK:

Using 6.0 mm needles and A, cast on **59-65-71-77** sts.

Work even in 1/1 Rib for **6 cm (2¼ in) [12 rows]**.

Using 7.0 mm needles, work in St st until piece measures **37-38-38-39 cm (14½-15-15-15¼ in) [64-66-66-68 rows]** total.

Raglan:

Cont in St st and Fair Isle foll chart according to size made, but starting on 1st row of raglan, cast off **2-3-3-3** sts at the beg of the next 2 rows. Then dec at each end as foll, 1 st in from edge:

S: starting on 3rd row, then every 4th row 1 st twice ; every 2nd row 1 st 13 times.

M: starting on 3rd row, then every 4th row 1 st twice ; every 2nd row 1 st 14 times.

L: starting on 3rd row, then every 2nd row 1 st 18 times.

XL: starting on 1st row, then every 2nd row 1 st 20 times.

To dec 1 st, 1 st in from edge: k1, k2 tog, cont row until 3 sts rem on left needle, k1, sl 1, pssso, k1.

Once you have completed the last row of chart, cast off the rem **25-27-29-31** rem sts for neck.

FRONT:

Using 6.0 mm needles and A, cast on **59-65-71-77** sts.

Work even in 1/1 Rib for **6 cm (2¼ in) [12 rows]**.

Using 7.0 mm needles, work in St st until piece measures **37-38-38-39 cm (14½-15-15-15¼ in) [64-66-66-68 rows]** total.

Raglan and neck:

Cont in St st and Fair Isle foll chart according to size made, but starting on 1st row of raglan, cast off **2-3-3-3** sts at the beg of the next 2 rows. Then dec as foll, 1 st in from edge:

S: starting on 3rd row, then every 4th row 1 st twice ; every 2nd row 1 st 11 times,

M: starting on 3rd row, then every 4th row 1 st twice ; every 2nd row 1 st 12 times,

L: starting on 3rd row, then every 2nd row 1 st 16 times,

XL: starting on 1st row, then every 2nd row 1 st 18 times,

but meanwhile, when work measures **56-58-60-62 cm (22-22¼-23½-24½ in) [92-96-98-102 rows]** total, **for neck** cast off the **15-17-19-21** center sts. Cont each side separately and cast off on neck side: 3 sts once and the rem 4 sts.

LEFT SLEEVE:

Using 6.0 mm needles and A, cast on **29-31-33-35** sts.

Work even in 1/1 Rib for **6 cm (2¼ in) [12 rows]**.

Using 7.0 mm needles, work in St st, and inc at each end as foll, 2 sts in from edge:

S: 1 st twice every 10th row, 1 st 5 times every 8th row.

M: 1 st 6 times every 8th row, 1 st twice every 6th row.

L: 1 st 3 times every 8th row, 1 st 6 times every 6th row.

XL: 1 st 10 times every 6th row.

Cont and work even on the **43-47-51-55** sts obtained until piece measures **46 cm (18 in) [80 rows]** total.

Raglan:

Cont in St st and Fair Isle foll chart according to size made, **but** starting on 1st row of raglan, cast off **2-3-3-3** sts at the beg of the next 2 rows. Then dec, 1 st in from edge, on **right** edge as for back, **at the same time** on **left** edge as for front, then cast off on left edge every 2nd row 5 sts once, 2 sts once, 4 sts once.

RIGHT SLEEVE:

Work as for left sleeve, rev shaping of raglan.

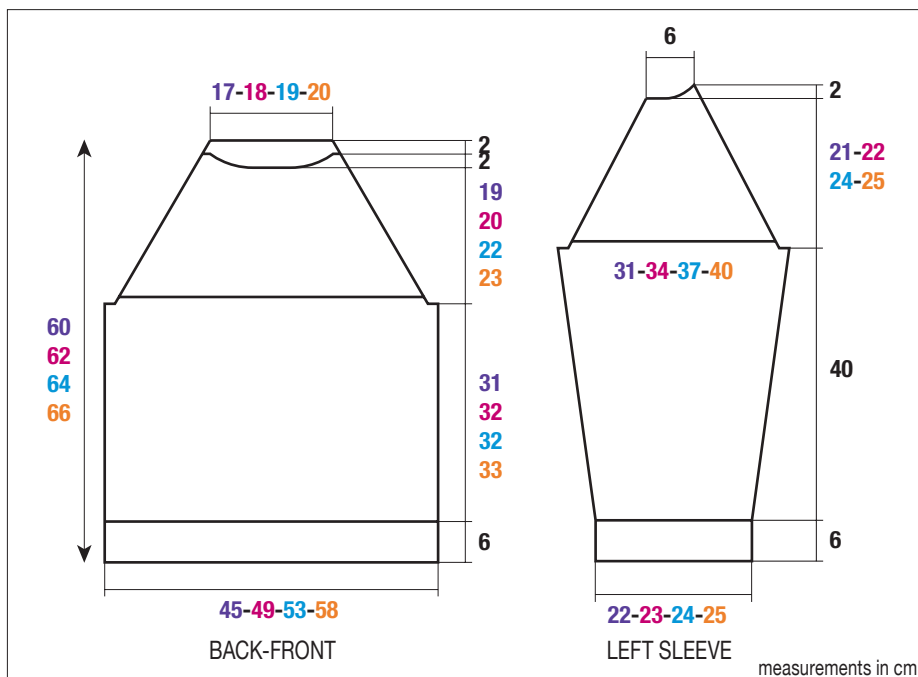

COLLAR:

Using 6.0 mm needles and B, cast on **65-69-73-77** sts.

Work even in 1/1 Rib for **3 cm (1¼ in) [6 rows]** and leave all sts on hold.

FINISHING:

Join raglans.

Graft collar to neck edge and join shorter ends (see grafting instructions).

Sew sleeve seams and sides of sweater.

Secure and weave in ends.

RAGLAN BACK-FRONT size S

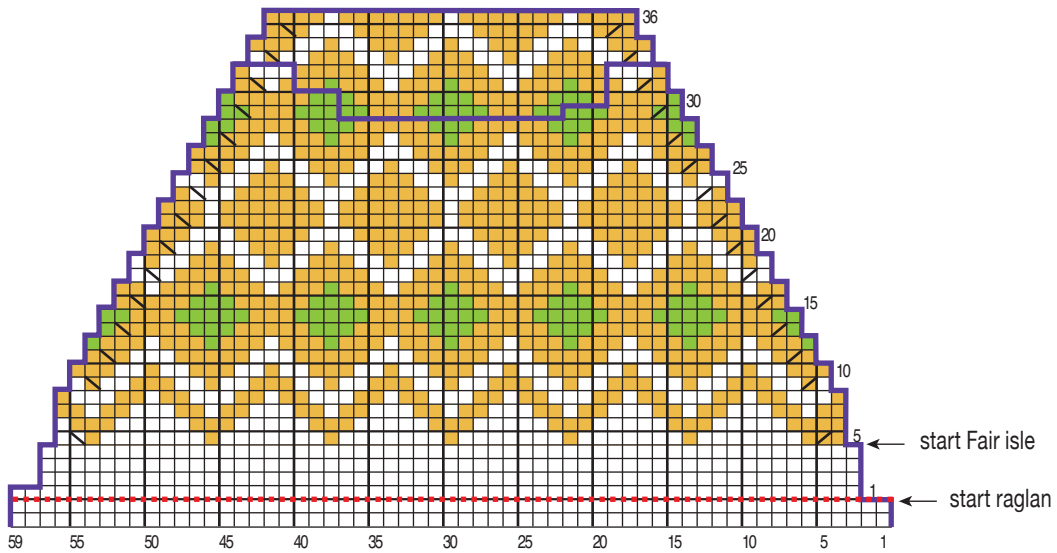

RAGLAN BACK-FRONT size M

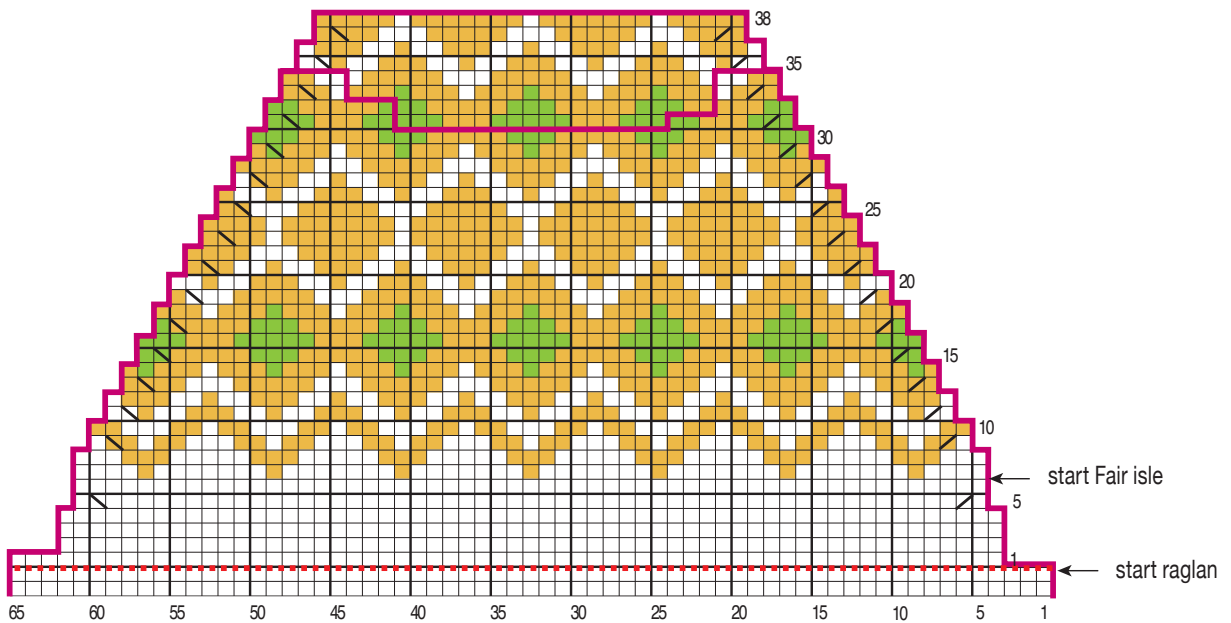

□	= 1 st A
■	= 1 st B
■	= 1 st C
▨	= k2tog
▩	= k1, sl1, pss0

RAGLAN BACK-FRONT size L

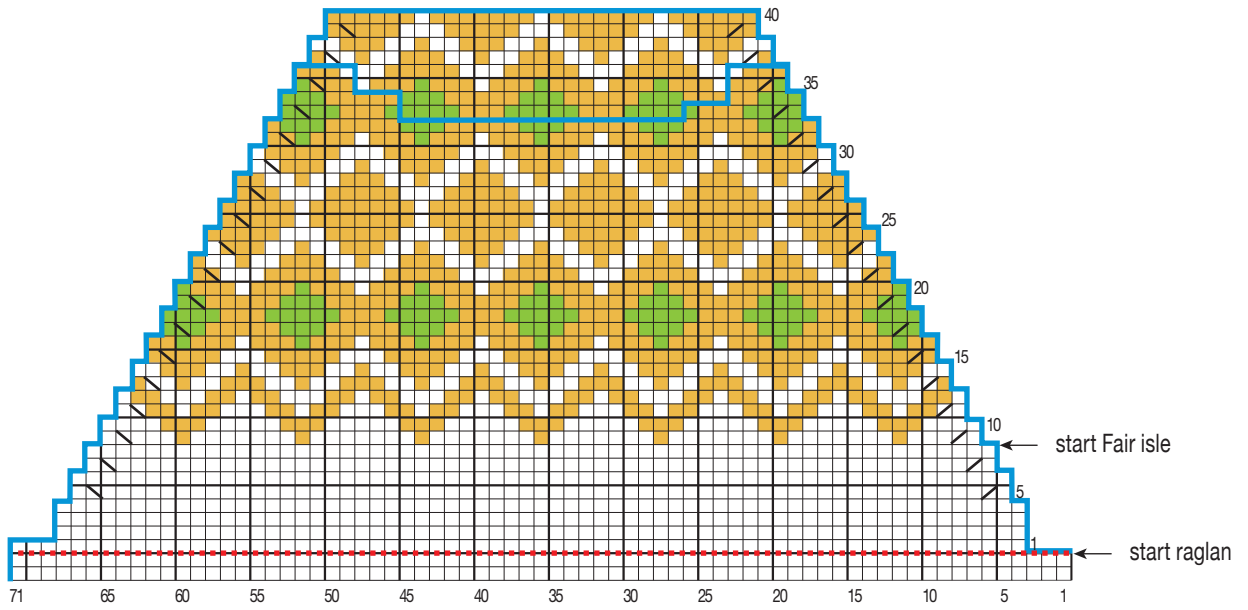

- = 1 st A
- = 1 st B
- = 1 st C
- ▨ = k2tog
- ▩ = k1, sl1, pss0

RAGLAN BACK-FRONT size XL

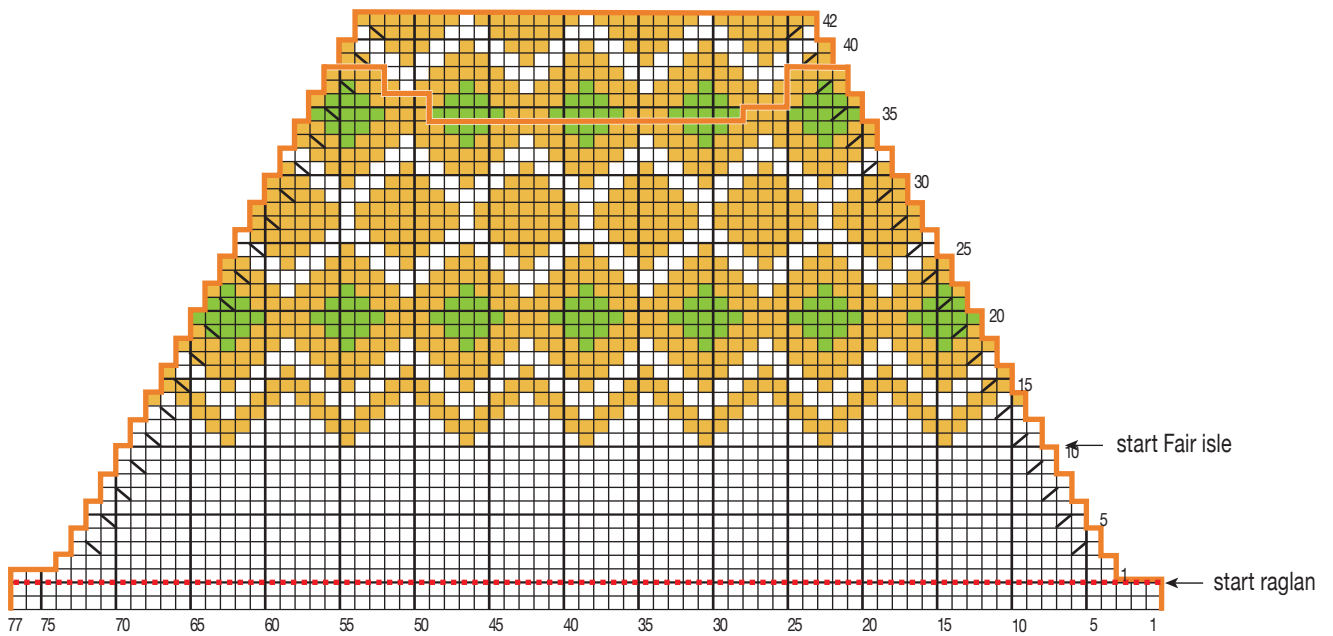

RAGLAN LEFT SLEEVE size S

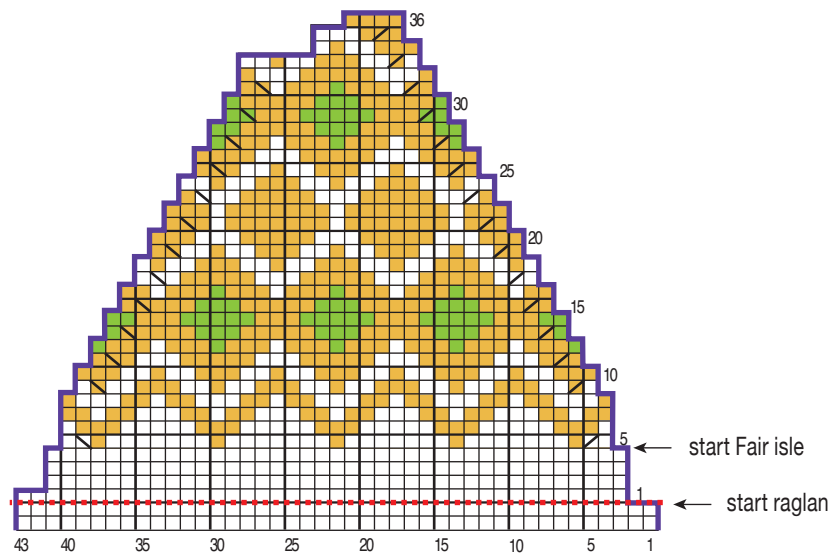

□	= 1 st A
■	= 1 st B
■	= 1 st C
▧	= k2tog
▨	= k1, sl1, pss0

RAGLAN LEFT SLEEVE size M

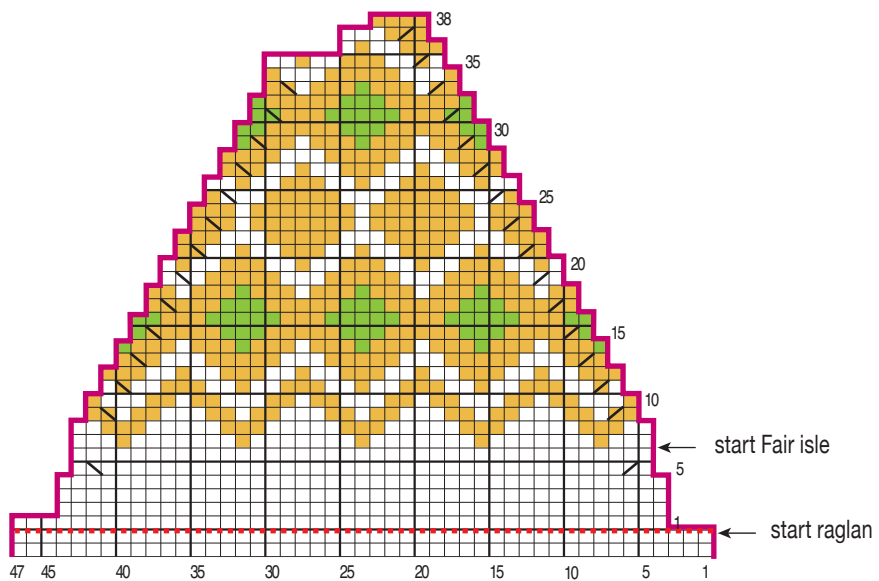

RAGLAN LEFT SLEEVE size L

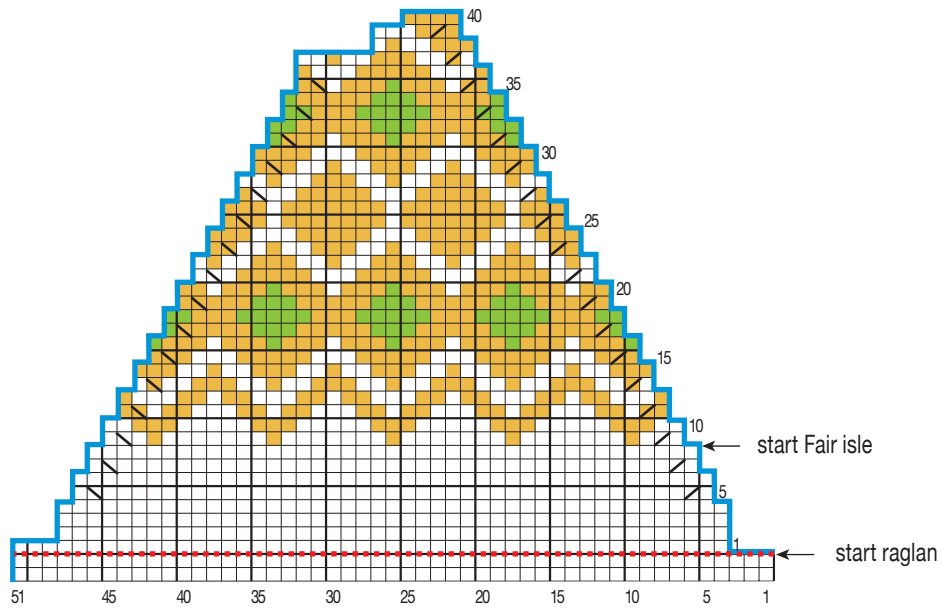

□	= 1 st A
■	= 1 st B
■	= 1 st C
↘	= k2tog
↘	= k1, sl1, pss0

RAGLAN LEFT SLEEVE size XL

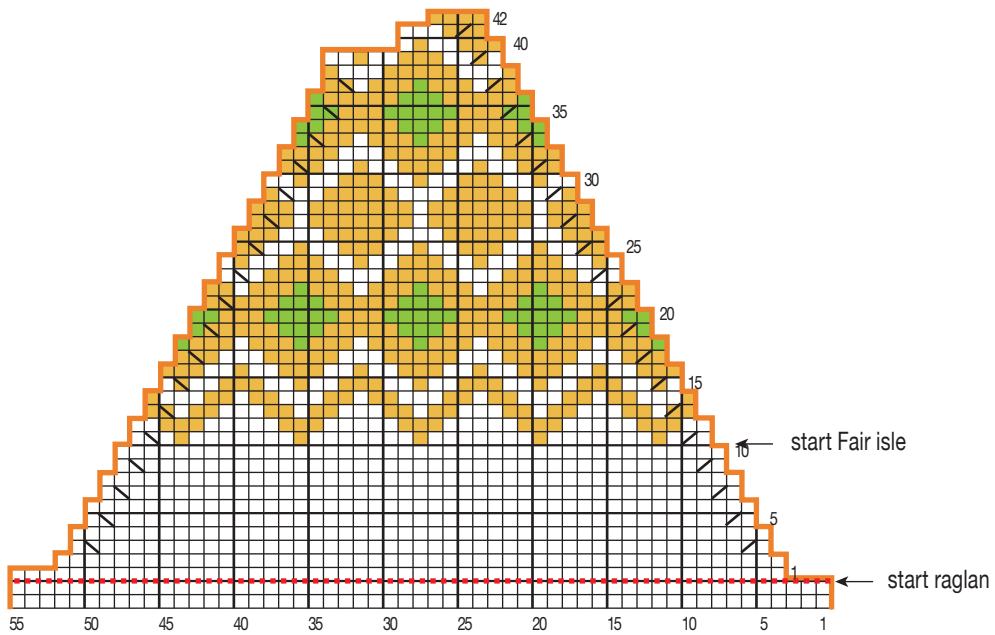

TURTLENECK SWEATER



Quality: **FILOMÈCHE**

Needles: **6.0 & 7.0 mm**

Accessories: **Stitch markers ref. 68395 (Pk of 48)**

Sizes		S	M	L	XL	XXL
Quality FILOMÈCHE		Number of balls				
Brownie	54592	12	13	14	16	17

Stitches used

GARTER STITCH (G. st), using 6.0 mm needles.
K all rows.

STOCKING STITCH (St st), using 7.0 mm needles.

Row 1: k

Row 2: p

PATTERN STITCH, using 7.0 mm needles.

Work 2 rows in St st, 2 rows in G. st.

Repeat those 4 rows.

Tension/Gauge

To achieve a good result, it is essential to make a tension square (See "Check Your Tension" instructions at beginning of book).

13 sts and 18 rows in Patt st (hold swatch vertically to measure) = 10 cm (4 in) square

13 sts and 17 rows in St st = 10 cm (4 in) square

To make

BACK:

Using 6.0 mm needles, cast on **67-72-77-83-90** sts.

Work even in G. st for **3 cm (1¼ in) [6 rows]**.

Change to 7.0 mm needles and work in Patt st until piece measures **44-45-45-46-47 cm (17½-17¾-17¾-18-18½ in) [80-82-82-84-86 rows]** total.

Beware, take this and any further measurement while holding the piece vertically.

Armholes:

Slip a stitch marker in first and last st to locate the beginning of armholes (see diagram) and continue to work in Pattern stitch until piece measures **61-63-65-67-69 cm (24-24¾-25½-26¼-27 in) [110-114-116-120-124 rows]** total.

Neck:

Cast off the **19-20-21-23-24** center sts. Then continue each side separately and cast off on neck side 2 sts once. Work even until piece measures **63-65-67-69-71 cm (24¾-25½-26¼-27-28 in) [114-118-120-124-128 rows]** total.

Shoulders:

Leave on hold the remaining **22-24-26-28-31** sts.

FRONT:

Start as for back until piece measures **44-45-45-46-47 cm (17½-17¾-17¾-18-18½ in) [80-82-82-84-86 rows]** total.

Armholes:

Place stitch markers as for back.

Neck:

When piece measures **56-58-60-62-64 cm (22-22¾-23½-24½-25¼ in) [102-106-108-112-116 rows]** total, cast off the **11-12-13-15-16** center sts. Continue each side separately and cast off on neck side every 2nd row: 2 sts twice, 1 st twice.

Shoulders:

Leave sts on hold as for back.

SLEEVES:

Using 6.0 mm needles, cast on **33-34-35-37-38** sts.

Work even in G. st for **3 cm (1¼ in) [6 rows]**.

Change to 7.0 mm needles and work in St st and increase at each end, 2 sts in from edge:

S: 1 st twice every 10th row, 1 st 7 times every 8th row.

M: 1 st 8 times every 8th row, 1 st twice every 6th row.

L and XL: 1 st 3 times every 8th row, 1 st 9 times every 6th row.

XXL: 1 st 13 times every 6th row.

Continue and work even on the **51-54-59-61-64** sts obtained until piece measures **53 cm (20¾ in) [92 rows]** total.

Top of sleeve:

Cast off all sts.

COLLAR:

Using 6.0 mm needles, cast on **66-68-70-72-74** sts.

Work even in G. st for **18 cm (7 in)** and leave all sts on hold.

FINISHING:

Join shoulders on WS using the 3 needle bind off technique (See "Knitting: Stitches/Techniques/Tips").

Graft collar to edge of collar (see Grafting instructions).

Join sides of collar so as to prepare a folded edge of 9 cm (3½ in).

Sew top of sleeves to armholes at each end of shoulder seam in between stitch markers.

Sew sleeve seams and sides of sweater.

Secure and weave in ends.

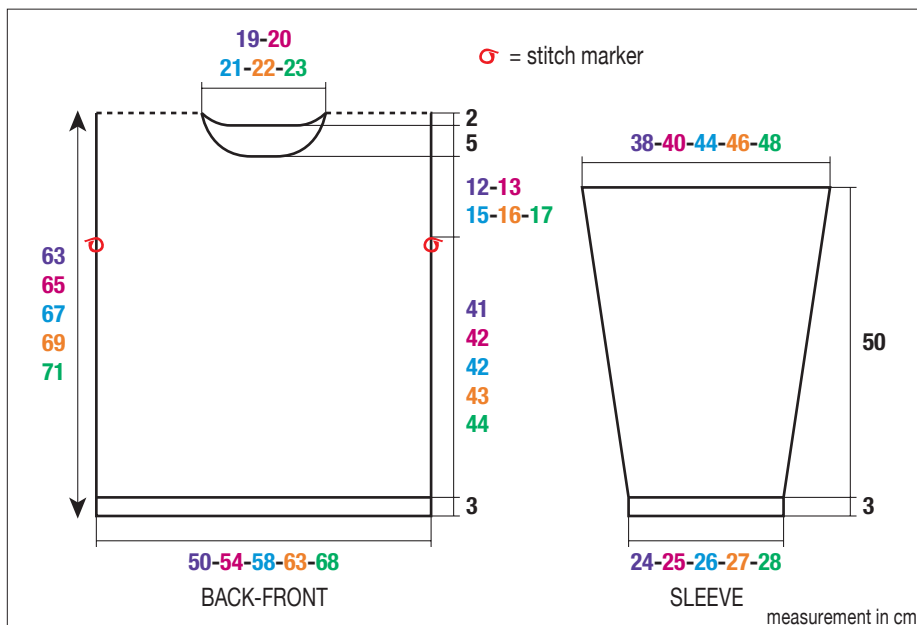

CAPE STYLE CARDIGAN



Quality:
FILOMÈCHE

Needles:
6.5 & 7.0 mm

Accessories:
10 granite buttons Ø 23 mm ref. 50080 (Pk of 5)

One Size

	Quality FILOMÈCHE	Number of balls
Spéculos (A)	54594	13
Ecru (B)	54586	2

Stitches used

2/2 RIB, using 6.5 mm needles.

STOCKING STITCH (St st), using 7.0 m needles.

FAIR ISLE, using 7.0 m needles. Foll chart.

Tension/Gauge

To achieve a good result, it is essential to make a tension square (See "Check Your Tension" instructions at beginning of book).

13 sts and 17 rows in St st = 10 cm (4 in) square

To make

BACK:

Using 6.5 mm needles and A, cast on **110** sts.

Work in 2/2 Rib for **2 cm (¾ in) [4 rows]**, but on last row, dec 7 sts evenly spaced across row.

Using 7.0 mm needles, work in striped St st as foll on the rem **103** sts:

12 rows with A, **2** rows with B,
2 rows with A, **2** rows with B,
2 rows with A, **2** rows with B,

then change to A and work even until piece measures **35 cm (13¾ in) [60 rows]** total.

Work as foll:

18 rows in Faire Isle foll chart,
then work in striped St st as foll:

18 rows with A, **2** rows with B,
2 rows with A, **2** rows with B,
end with A,

but meanwhile, when piece measures **51 cm (20 in) [86 rows]** total, **for shoulders** cast off at the beg of every row: 3 sts 18 times, 4 sts 8 times,

and at the same time when working the **11th** dec of 1st shoulder, **for neck** cast off the center **13** sts, and continue each side separately, and cast off on neck side 2 sts once.

LEFT FRONT:

Using 6.5 mm needles and A, cast on **46** sts.

Work in 2/2 Rib for **2 cm (¾ in) [4 rows]**, **but** on last row, dec **3** sts evenly spaced across row.

Using 7.0 mm needles, work in striped St st and Fair Isle as for back on the rem **43** rem sts, **but meanwhile**, when piece measures **51 cm (20 in) [86 rows]** total, **for shoulder** cast off on right edge as for back.

RIGHT FRONT:

Using 6.5 mm needles and A, cast on **46** sts.

Work in 2/2 Rib for **2 cm (¾ in) [4 rows]**, but on last row, dec 3 sts evenly spaced across row.

Using 7.0 mm needles, work in striped St st and Fair Isle as for back on the rem **43** sts, **but meanwhile**, when piece measures **51 cm (86 rows)** total, **for shoulder** cast off on left edge as for back.

FINISHING:

Join shoulder seams.

Edging 1 (right front and half-collar) :

– Using 6.5 mm needles and A, pick up and k **128** sts along the right front up to center center of

back neck, then cast on **1** extra st after those sts for the seam (= **129** sts).

– Work even in 2/2 Rib starting with k2 and ending with p3.

– On **2nd** row, work **4** sts in 2/2 Rib, yo and k2 tog (= 1 buttonhole), **18** sts in 2/2 Rib, yo and k2 tog (= 1 buttonhole) and work row to end.

– Work even in 2/2 Rib for **21** rows.

– Next row: create 2 buttonholes as you did previously.

– Work in 2/2 Rib for **1** more row and cast off all sts.

Edging 2 (left front and half-collar) :

– Using 6.5 mm needles and A, cast on 1 st for seam, then pick up and k **128** sts starting in center of back neck then along left front (= **129** sts).

– Work even in 2/2 Rib for **25** rows, starting with p3.

– Cast off all sts.

Edgings 3 and 4 (armholes and sides) :

– Using 6.5 mm needles and A, pick up and k **180** sts at each end of the cape, along the back and front (= red lines on diagram),

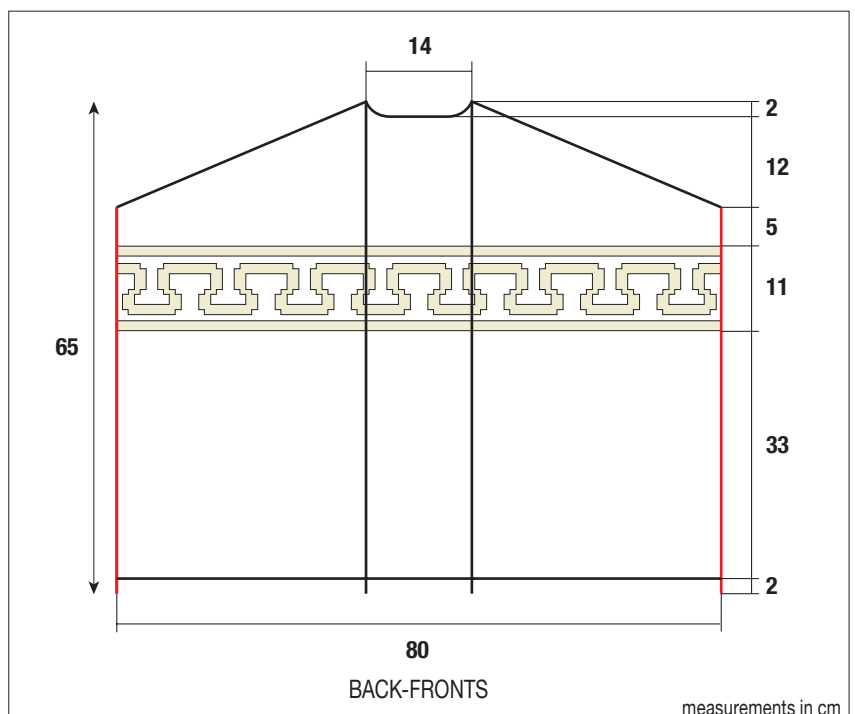

- Work in 2/2 Rib for 4 rows starting and ending with p3.

- Cast off all sts.

Join both half-collars in order to obtain an 8cm (3 in) folded edge.

Attach 4 buttons to Edging 2, facing buttonholes.

Along each front, attach 3 buttons to Edgings 3 and 4 through both layers, overlapping the front section over back section: the 1st one located 2 cm (¾ in) in from lower edge, the 2nd one 17cm (6¾ in) high total, the 3rd one located in between.

Secure and weave in ends.

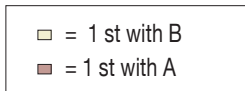

FAIR ISLE

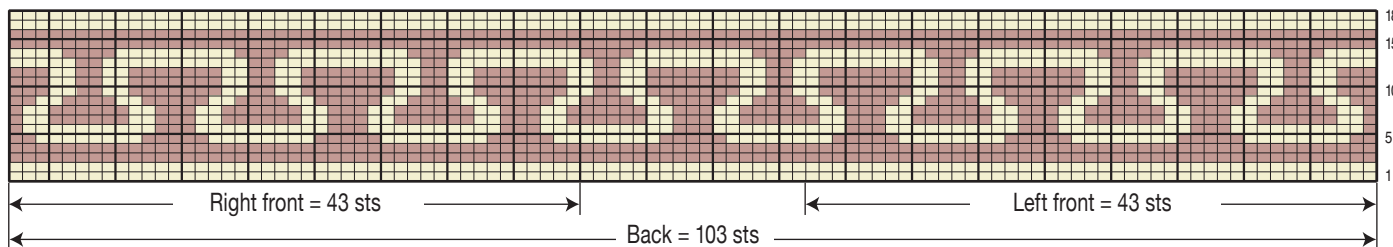

CROPPED CARDIGAN



Quality:
FILOMÈCHE

Needles:
6.5 mm



Accessories:

1 brown imitation leather button fastening ref. 66252

Small amounts of PUR MÉRINOS FRANÇAIS yarn in col Grège ref. 29115 and Cuba ref. 29534 (for embroidery)

Brown sewing thread (not sold)

Sizes		S	M	L	XL	XXL
Quality FILOMÈCHE		Number of balls				
Babe	54619	8	9	9	10	11

● Abbreviation

1 slipped st: Slip 1 st purlwise leaving yarn on **RS** of work.

tbl : through back of loop

● Stitches used

PATTERNED RIB, using 6.5 mm needles. Worked over an uneven number of sts.

Row 1 (RS): k1 tbl, * p1, k1 tbl *, repeat from * to *.

Row 2: p1 tbl, * k1, p1 tbl *, repeat from * to *.

Repeat those 2 rows.

1-ST EDGING A, using 6.5 mm needles.

Row 1 (RS): k1 tbl.

Row 2: 1 slipped st.

Repeat those 2 rows.

1-ST EDGING B, using 6.5 mm needles.

Row 1 (RS): 1 slipped st.

Row 2: p1 tbl.

Repeat those 2 rows.

REVERSE STOCKING STITCH (Rev St st), using 6.5 mm needles.

Row 1: p

Row 2: k

Embroidery stitches: See “Embroidery: Stitches”

● Tension/Gauge

To achieve a good result, it is essential to make a tension square (See “Check Your Tension” instructions at beginning of book).

16 sts and 16 rows in Patterned rib = 10 cm (4 in) square

● To make

BACK:

Cast on **79-85-91-99-107** sts. Work even in Patterned rib until piece measures **26-27-27-28-29** cm (**10½-10¾-20¾-11-11½** in) [**42-44-44-46-48** rows] total.

Armholes:

Cast off **5** sts at the beginning of the next 2 rows.

Continue and work even on the remaining **69-75-81-89-97** sts until piece measures **42-44-46-48-50** cm (**16½-17½-18-19-19¾** in) [**66-70-72-76-80** rows] total.

Neck:

Cast off the **11-11-13-13-13** center sts. Then continue each side separately and cast off on neck side 2 sts once.

Shoulders:

When piece measures **44-46-48-50-52** cm (**17½-18-19-19¾-20½** in) [**70-74-76-80-84** rows] total, leave the remaining **27-30-32-36-40** sts on hold.

LEFT FRONT:

Cast on **40-42-46-50-54** sts.

Work **39-41-45-49-53** sts in Patterned Rib, 1 st Edging **A**.

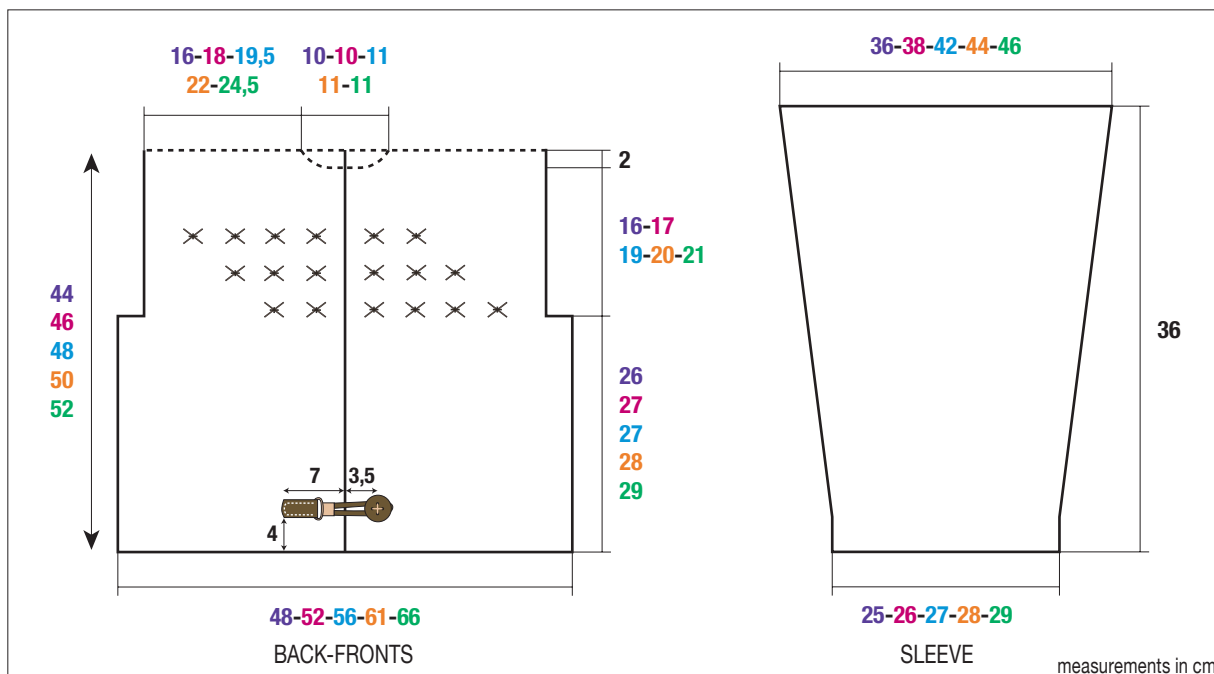

Armhole:

Cast off on right edge as for back.

Continue and work even on the remaining **35-37-41-45-49** sts until piece measures **44-46-48-50-52** cm (**17½-18-19-19¼-20½** in) [**70-74-76-80-84** rows] total.

Shoulder and half-collar:

For shoulder leave on hold the first **27-30-32-36-40** sts, then, **for half-collar** continue the Patterned rib and Edging st for **5-5-5.5-5.5-5.5** cm (**2-2-2¼-2¼-2¼** in) on the remaining **8-7-9-9-9** sts and cast on 1 extra st on neck side for seam (= **9-8-10-10-10** sts). Then leave all sts on hold.

RIGHT FRONT:

Cast on **40-42-46-50-54** sts.

Work **1** st Edging B, **39-41-45-49-53** sts in Patterned Rib.

Armhole:

Cast off on left edge as for back.

Continue and work even on the remaining **35-37-41-45-49** sts until piece measures **44-46-48-50-52** cm (**17½-18-19-19¼-20½** in) [**70-74-76-80-84** rows] total.

Shoulder and half-collar:

For shoulder leave on hold the last **27-30-32-36-40** sts, then, **for half-collar** continue the Patterned rib and Edging st for **5-5-5.5-5.5-5.5** cm (**2-2-2¼-2¼-2¼** in) on the remaining **8-7-9-9-9** sts and cast on 1 extra st on neck side for seam (= **9-8-10-10-10** sts), and leave all sts on hold.

SLEEVES:

Cast on **41-43-45-47-49** sts.

Work even in Patterned rib and increase at each end, 2 sts in from edge, as follows:

S: 1 st 5 times every 6th row, 1 st 4 times every 4th row.

M: 1 st 3 times every 6th row, 1 st 7 times every 4th row.

L: 1 st 12 times every 4th row.

XL and XXL: 1 st 11 times every 4th row, 1 st twice every 2nd row.

Continue and work even on the **59-63-69-73-75** sts obtained until piece measures **36** cm (**14** in) [**58** rows] total.

Top of sleeve:

Cast off all sts.

FINISHING:

Embroidery:

– Embroider the right front following chart, starting on 1st row of armhole and place stitch **X** on the **4th-4th-6th-8th-10th** st in from front center edge.

– Embroider the left front following chart, starting on 1st row of armhole and place stitch **Y** on the **4th-4th-6th-8th-10th** st in from front center edge.

Prepare the fastening: To make it easier to sew, pierce holes evenly spaced (using a sewing machine or sewing needle) the part of the fastening to be sewn (= white dots on diagram).

Using sewing thread, attach the loop part of the fastening to right front, and the WS of the button to left front (see diagram).

Join shoulders using the 3 needles bind off technique (See “Knitting: Stitches/Techniques/Tips”).

Graft the smaller ends of the half-collars on WS (see grafting instructions), and sew the collar obtained to edge of back neck.

Sew top of sleeves to vertical part of armholes.

Sew sleeve seams and sides of cardigan.

Secure and weave in ends.

EMBROIDERY

RIGHT FRONT

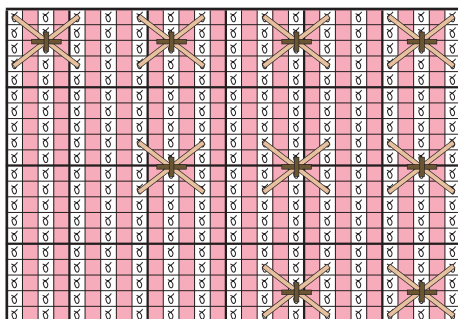

X

LEFT FRONT

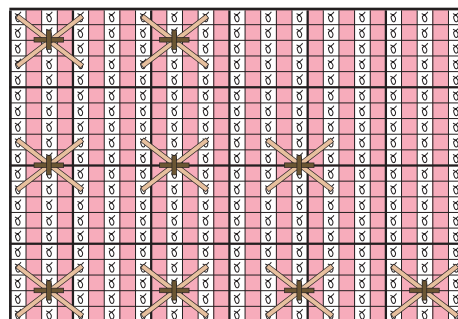

Y

☒ = k1 or p1 tbl

■ = 1 Reverse Stocking st

— = straight stitch using 1 strand PUR MÉRINOS FRANÇAIS Grège

— = straight stitch using 1 strand PUR MÉRINOS FRANÇAIS Cuba

TURTLENECK CABLED SWEATER



Quality:
FILOMÈCHE

Needles:
6.0 & 7.0 mm
1 cable needle (CN)

Accessories:
Stitches markers ref. 68395 (pk of 48)

Sizes		S	M	L	XL	XXL
Quality FILOMÈCHE		Number of balls				
Merle	54597	12	14	15	16	18

● Abbreviations

Right cross = CR

Left cross = CL

5CRp: Slip 3 sts to CN at back of work, k the next 2 sts, then sl the p st from CN to left needle and p this st, then k the 2 sts from CN.

3CRp: Slip 1 st to CN at back of work, k the next 2 sts, then p the st from CN.

3CLp: Slip 2 sts to CN in front of work, p the next st, then k the 2 sts from CN.

1 bobble: in the same st work k1, do not drop st from left needle and p this same st, k the st, p the st, then drop it from left needle. Turn work, p4, turn, k4, turn, p4 tog, turn, and sl this st to right needle.

● Stitches used

2/2 RIB, using 6.0 mm needles.

STOCKING STITCH (St st), using 7.0 mm needles.

REVERSE STOCKING STITCH (Rev St st), using 7.0 mm needles.

PATTERN STITCH (Patt st), using 7.0 mm needles. Worked over 63 sts. Foll chart.

● Tension/Gauge

To achieve a good result, it is essential to make a tension square (See "Check Your Tension" instructions at beginning of book).

13 sts and 17 rows in St st = 10 cm (4 in) square

● To make

BACK:

Using 6.0 mm needles, cast on **70-76-80-86-94** sts.

Work even in 2/2 Rib until piece measures **5 cm (2 in)** [10 rows], starting and ending with:

S, XL and XXL: k2.

M and L: k3.

Change to 7.0 mm needles and work even in St st until piece measures **44-45-45-46-47 cm (17½-17¾-17¾-18-18½ in)** [76-78-78-80-82 rows] total, **but** on 1st row for **sizes S, M and XXL** dec 1 st (= **69-75-80-86-93** sts).

Armholes:

Slip a st marker in first and last st to locate beg of armholes (see diagram) and cont to work in St st until piece measures **64-66-68-70-72 cm (25¼-26-26¾-27½-28¼ in)** [110-114-116-120-124 rows] total.

Shoulders and neck:

For shoulders cast off at the beginning of every row as foll:

S: 7 sts 4 times, 8 sts twice,

M: 8 sts 6 times,

L: 8 sts twice, 9 sts 4 times,

XL: 9 sts 4 times, 10 sts twice,

XXL: 10 sts 4 times, 11 sts twice,

at the same time when working the 1st shoulder dec, **for neck** cast off the **21-23-24-26-27** center sts. Cont each side separately and cast off on neck side 2 sts once.

FRONT:

Using 6.0 mm needles, cast on **70-76-80-86-94** sts.

Work even in 2/2 Rib until piece measures **5 cm (2 in)** [10 rows], starting and ending with:

S, XL and XXL: k2.

M: p3.

L: k3.

Change to 7.0 mm needles and work **6-9-11-14-18** sts in St st, **63** sts in Patt st and inc **5** sts evenly spaced across 1st row (see placement on chart), **6-9-11-14-18** sts in St st (= **75-81-85-91-99** sts).

Armholes:

Place st markers as for back.

Neck:

When piece measures **58-60-62-64-66 cm (22¾-23½-24½-25¼-26 in)** [100-104-106-110-114 rows] total, cast off the **13-15-15-17-19** center sts. Cont each side separately and cast off on neck side every 2nd row: 3 sts once, 2 sts once, 1 st twice.

Work even until piece measures **64-66-68-70-72 cm (25¼-26-26¾-27½-28¼ in)** [110-114-116-120-124 rows] total.

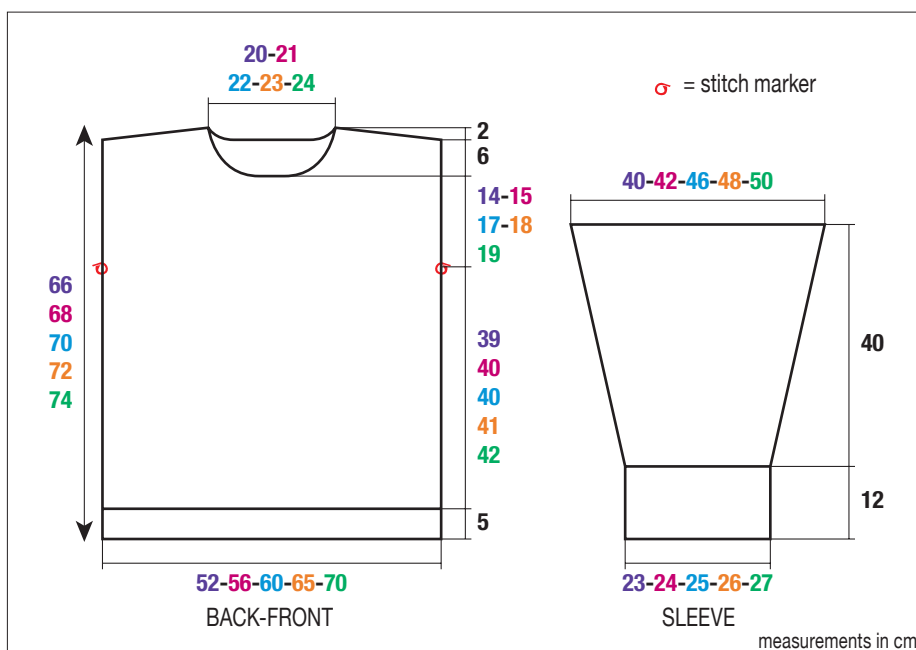

Shoulders:

Cast off on shoulder edge every 2nd row:

S: 8 sts 3 times.

M: 8 sts once, 9 sts twice.

L: 9 sts twice, 10 sts once.

XL: 10 sts 3 times.

XXL: 11 sts 3 times.

SLEEVES:

Cast on **32-34-34-36-36** sts.

Work even in 2/2 Rib until piece measures **12 cm (4¾ in) [24 rows]**, starting and ending with:

S, XL and XXL: k3.

M and L: k2.

Change to 7.0 mm needles and work in St st until piece measures **15 cm (6 in) [30 rows]** total, **but** on 1st row **for size M** dec 1 st, **sizes L and XXL** inc 1 st (= **32-33-35-36-37** sts).

Inc at each end, 2 sts in from edge:

S: 1 st 7 times every 6th row, 1 st 4 times every 4th row.

M: 1 st 5 times every 6th row, 1 st 7 times every 4th row.

L: 1 st 3 times every 6th row, 1 st 10 times every 4th row.

XL: 1 st 14 times every 4th row.

XXL: 1 st 15 times every 4th row.

Cont and work even on the **54-57-61-64-67** sts obtained until piece measures **52 cm (20½ in) [92 rows]** total.

Top of sleeve:

Cast off all sleeves.

COLLAR:

Using 6.0 mm needles, cast on **94-98-102-106-110** sts.

Work in 2/2 Rib for **12 cm (4¾ in) [24 rows]** and leave all sts on hold.

FINISHING:

Join shoulder seams.

Graft collar to neck edge (see Grafting instructions) and join the shorter ends.

Sew top of sleeves to armhole edges at each end of shoulder seam in between stitch markers.

Sew sleeve seams and sides of sweater.

Secure and weave in ends.

PATTERN STITCH

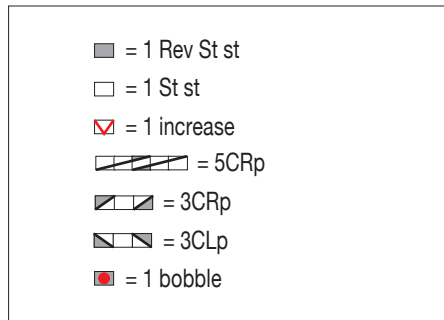
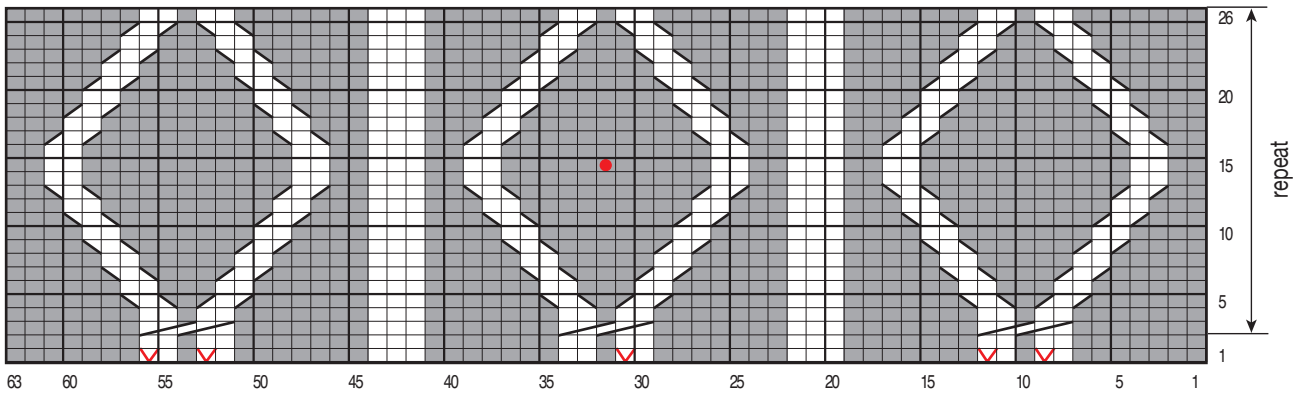

SWEATER WITH ROUND COLLAR



Quality: **FILOMÈCHE**
Needles: **6.0 & 7.0 mm**

Sizes		4 yrs	6 yrs	8 yrs	10 yrs	12 yrs
Quality FILOMÈCHE		Number of balls				
Gris	54620	5	6	7	7	8

● **Stitches used**

2/2 RIB, using 6.0 mm needles.

Row 1 : *k2, p2*, rep from * to *.

Row 2 : k over k, p over p.

STOCKING STITCH (St st), using 7.0 mm needles.

Row 1: k

Row 2: p

● **Tension/Gauge**

To achieve a good result, it is essential to make a tension square (See "Check Your Tension" instructions at beginning of book).

13 sts and 17 rows in St st = 10 cm (4 in) square

● **To make**

BACK:

Using 6.0 mm needles, cast on **42-46-50-54-58** sts.

Work in 2/2 Rib for **4 cm (1½ in) [8 rows]**, **but** on last row increase 1 st.

Change to 7.0 mm needles and work in St st on the **43-47-51-55-59** sts obtained until piece measures **25-28-31-34-37 cm (10-11-12¼-13¼-14½ in) [44-48-54-60-64 rows]** total.

Raglan :

Cast off **2-2-3-3-3** sts at the beginning of the next 2 rows.

Then decrease as follows, 2 sts in from edge:

4 years : starting on 3rd row, then every 2nd row 1 st 11 times

6 years : starting on 3rd row, then every 2nd row 1 st 12 times

8 years : starting on 3rd row, then every 2nd row 1 st 13 times

10 years : starting on 1st row, then every 2nd row 1 st 14 times

12 years : starting on 1st row, then every 2nd row 1 st 15 times

To decrease 1 st, 2 sts in from edge: k2, k2 together, continue row until 4 sts remain on left needle, k1, slip 1 st, pass slipped st over, k2.

After the last raglan decrease, work even for 1 row on the remaining **17-19-19-21-23** sts and cast off all sts **for neck**.

FRONT:

Start as for back up to raglan.

Raglan and neck:

When piece measures **25-28-31-34-37 cm (10-11-12¼-13¼-14½ in) [44-48-54-60-64 rows]** total, **for raglan** cast off **2-2-3-3-3** m sts at the beginning of the next 2 rows.

Then decrease as follows, 2 sts in from edge:

4 years : starting on 3rd row, then every 2nd row 1 st 9 times,

6 years : starting on 3rd row, then every 2nd row 1 st 10 times,

8 years : starting on 3rd row, then every 2nd row 1 st 11 times,

10 years : starting on 1st row, then every 2nd row 1 st 12 times,

12 years : starting on 1st row, then every 2nd row 1 st 13 times,

but meanwhile, when work measures **34-38-42-46-50 cm (13¼-15-16½-18-19¾ in) [60-66-74-80-86 rows]** total, **for neck** cast off the **9-11-11-13-15** center sts.

Continue each side separately and cast off on neck side every 2nd row 1 st twice and the remaining 4 sts.

LEFT SLEEVE:

Using 6.0 mm needles, cast on **26-26-30-30-30** sts.

Work in 2/2 Rib for **4 cm (1½ in) [8 rows]**, **but** on last row : **size 6 years** increase 1 st at each end ; **sizes 10 years and 12 years** increase 1 st (= **26-28-30-31-31** sts).

Change to 7.0 mm needles and St st and increase at each end, 2 sts in from edge as follows:

4 years and 6 years : 1 st 3 times every 10th row.

8 years : 1 st 4 times every 10th row.

10 years : 1 st 3 times every 10th row, 1 st twice every 8th row.

12 years : 1 st 3 times every 10th row, 1 st 3 times every 8th row.

Continue and work even on the **32-34-38-41-43** sts obtained until piece measures **26-30-33-37-41 cm (10½-12-13-14½-16 in) [46-52-58-64-72 rows]** total.

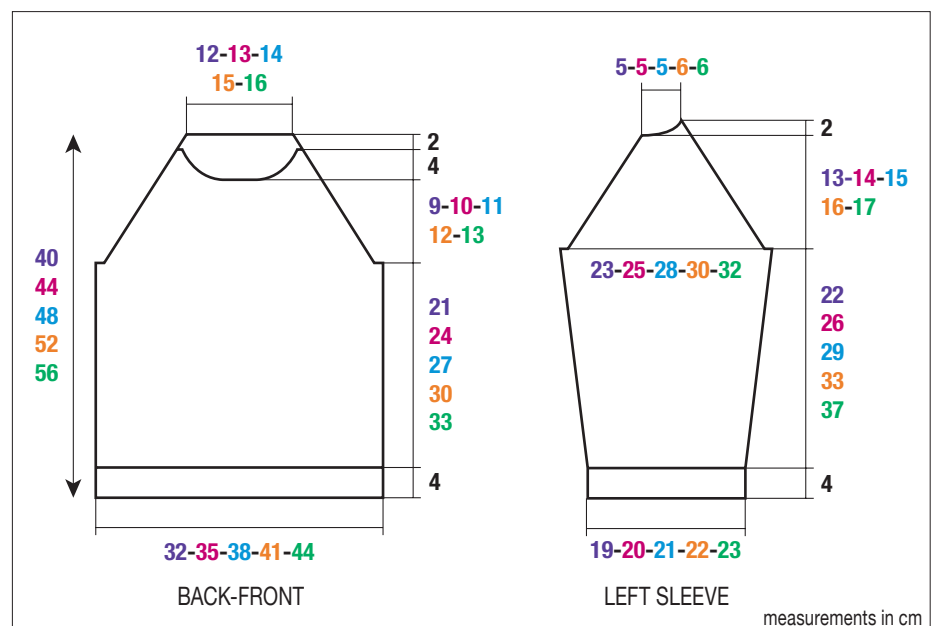

Raglan:

Cast off **2-2-3-3-3** sts at the beginning of the next 2 rows, then decrease on **right** edge as for back, **at the same** time on **left** edge as for front ; then cast off on left edge every 2nd row as follows:

4 years, 6 years and 8 years : 3 sts once, 1 st once and the remaining 4 sts.

10 years and 12 years : 4 sts once, 1 st once and the remaining 4 sts.

RIGHT SLEEVE:

Work as for left sleeve, reversing shaping of raglan.

COLLAR:

Using 6.0 mm needles, cast on **62-66-66-70-74** sts.

Work in 2/2 Rib for **5** rows and leave all sts on hold.

FINISHING:

Join raglans.

Graft collar to neck edge (See Grafting instructions) and join shorter ends.

Sew sleeve seams and sides of sweater.

Secure and weave in ends.



10

HOODED JACKET

Quality: **FILOMÈCHE**

Needles: **7.0 mm**



Accessories:
4 toggle buttons made of box wood 30 mm ref. 63991 (Pk of 6)

Sizes		4 yrs	6 yrs	8 yrs	10 yrs	12 yrs
Quality FILOMÈCHE		Number of balls				
Lave	54617	9	10	12	14	16

● Stitch used

GARTER STITCH (G. st), using 7.0 mm needles.
K all sts.

● Tension/Gauge

To achieve a good result, it is essential to make a tension square (See "Check Your Tension" instructions at beginning of book).

12.5 sts and 23 rows in G. st (hold swatch vertically to measure) = 10 cm (4 in) square

● To make

BACK:

Cast on **44-47-52-55-59** sts.

Work even in G. st until piece measures **31-35-39-43-47** cm (**12¼-13¾-15¼-17-18½** in) [**72-82-90-100-108** rows] total.

Beware, take this and any further measurement while holding the piece vertically.

Armholes :

Cast off **2** sts at the beginning of the next 2 rows.

Continue and work even on the remaining **40-43-48-51-55** sts until piece measures **45-50-55-60-65** cm (**17¾-19¾-21½-23½-25½** in) [**104-116-126-138-150** rows] total.

Shoulders and neck:

For shoulders, cast off **10-11-13-14-15** sts and work row to end.

Next row: cast off **10-11-13-14-15** sts and work row to end.

Then leave on hold the remaining **20-21-22-23-25** sts for neck.

Armhole :

Cast off 2 sts on right edge.

Then continue on the remaining **23-25-27-29-31** sts until piece measures **43-48-53-58-63** cm (**17-19-20¾-22¾-24¾** in) [**100-112-122-134-146** rows] total.

Neck :

Leave on hold the left **13-14-14-15-16** sts, then continue on the right **10-11-13-14-15** sts.

Work even until piece measures **45-50-55-60-65** cm (**17¾-19¾-21½-23½-25½** in) [**104-116-126-138-150** rows] total.

LEFT FRONT:

Cast on **25-27-29-31-33** sts. Work even in G. st until piece measures **31-35-39-43-47** cm (**12¼-13¾-15¼-17-18½** in) [**72-82-90-100-108** rows] total.

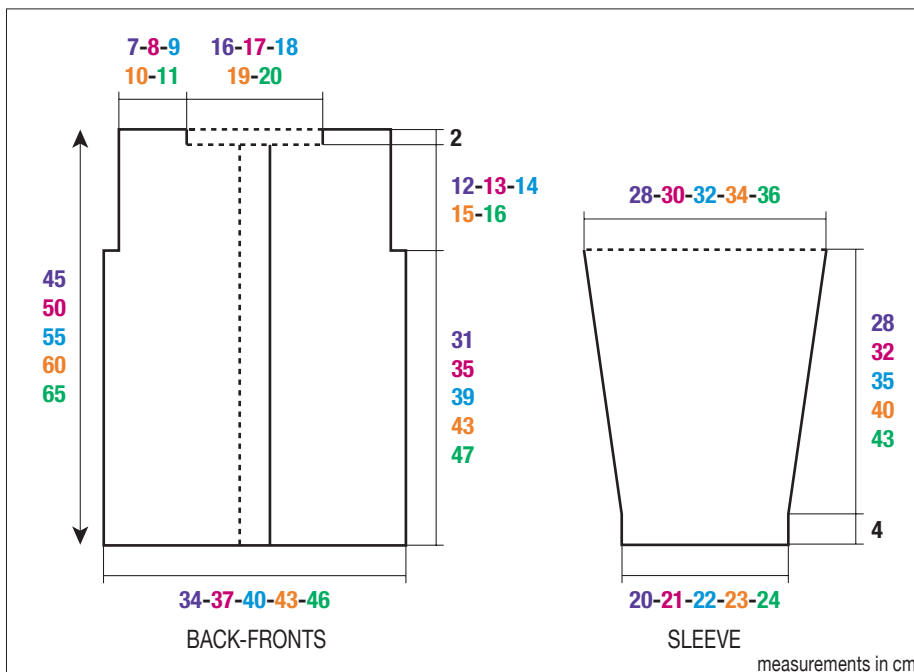

Shoulder:

Cast off all sts.

RIGHT FRONT:

Cast on **25-27-29-31-33** sts.

Work even in G. st until piece measures approximately **14-17,5-19-21,5-24** cm (**5½-6¾-7½-8½-9½** in) [**34-40-44-50-56** rows] total.

Buttonholes :

K3, k2 tog and yarnover (= 1 buttonhole) and work row to end.

Work even until piece measures approximately **23-27-29,5-33-36,5** cm (**9-10¾-11½-13-14½** in) [**54-62-68-76-84** rows] total.

Make 1 buttonhole as previously.

Work even until piece measures **31-35-39-43-47** cm (**12¼-13¾-15¼-17-18½** in) [**72-82-90-100-108** rows] total.

Armhole:

Cast off 2 sts on left edge.

Then continue on the remaining **23-25-27-29-31** sts until piece measures approximately **32-36,5-40-44,5-49** cm (**12½-14¼-15¾-17½-19¼** in) [**74-84-92-102-112** rows] total.

Make 1 buttonhole as previously.

Work even until piece measures **41-46-50,5-56-61,5** cm (**16-18-20-22-24¼** in) [**94-106-116-128-140** rows] total.

Make 1 buttonhole as previously.

Work even until piece measures until piece measures **43-48-53-58-63** cm (**17-19-20¾-22¾-24¾** in) [**100-112-122-134-146** rows] total.

Neck:

Leave on hold the right **13-14-14-15-16** sts.

Continue even on the left **10-11-13-14-15** sts until piece measures **45-50-55-60-65** cm (**17¾-19¾-21½-23½-25½** in) [**104-116-126-138-150** rows] total.

Shoulder:

Cast off all sts.

SLEEVES:

Cast on **27-28-29-31-32** sts.

Work even in G. st until piece measures **4** cm (**1½** in) [**10** rows].

Increase at each end, 1 st in from edge:

4 years : 1 st twice every 14th row, 1 st 3 times every 12th row.

6 years : 1 st 6 times every 12th row.

8 years : 1 st 5 times every 12th row, 1 st twice every 10th row.

10 years : 1 st 4 times every 14th row, 1 st 3 times every 12th row.

12 years : 1 st 8 times every 12th row.

Continue and work even on the **37-40-43-45-48** sts obtained until piece measures **32-36-39-44-47** cm (**12½-14-15¼-17½-18½** in) [**74-84-90-102-108** rows] total.

Top of sleeve:

Leave all sts on hold.

FINISHING:

Join shoulder seams.

Hood:

– Slip on one needle the **13-14-14-15-16** sts left on hold on left front, the **20-21-22-23-25** sts of back, then the **13-14-14-15-16** sts of right front (= **46-49-50-53-57** sts).

– Then k **13-14-14-15-16** sts, pick up **2-2-3-2-2** sts along the vertical section of right front neck, k **20-21-22-23-25** sts, pick up 2 sts along the vertical section of left front neck, k **13-14-14-15-16** sts.

– Continue in G. st on the **50-53-55-57-61** sts obtained until piece measures **28-29-30-31-32** cm (**11-11½-12-12¼-12½** in) [**64-66-70-72-74** rows] since starting collar.

– Leave all sts on hold.

– Close top of hood on WS using the 3 needle bind off technique (See “Knitting: Stitches/Techniques/Tips”).

Graft top of sleeves to vertical part of armholes (see Grafting instructions).

Sew sleeve seams and sides of jacket.

Attach toggle buttons.

Secure and weave in ends.

