

PATTERN INSTRUCTIONS

BERGERE
DE FRANCE

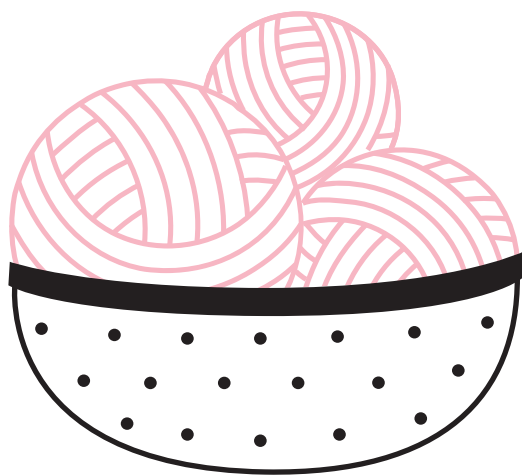

DON'T PANIC !

**BERGERE DE FRANCE IS
ACCOMPANYING ME STEP BY STEP**



OUR DEDICATED EMAIL

Stuck in the middle of your work? Need a clarification concerning the instructions? Do not hesitate to contact us. An expert knitter will take the time to provide the answers and all the help you need.

knittingquery@bergeredefrance.com

From Monday to Friday, during office hours



OUR WEBSITE

www.bergeredefrance.co.uk/knitting-basics-get-started

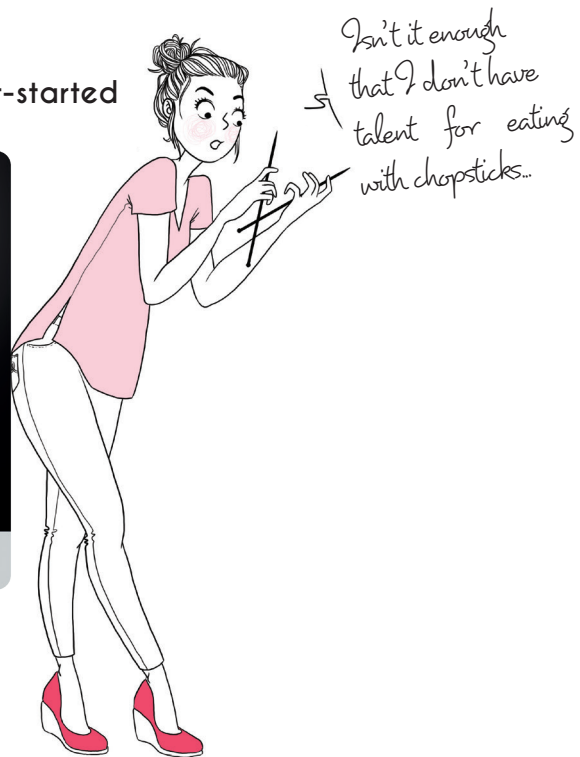
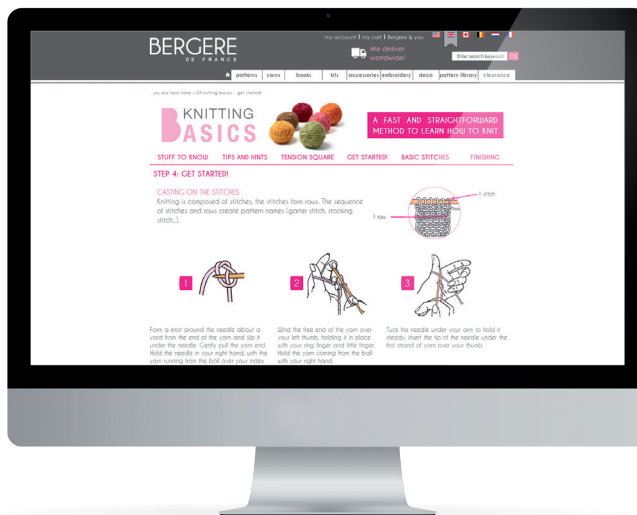

OUR YOUTUBE CHANNEL

All our video tutorials (in french) are available at :
www.youtube.com/bergerefr

Stuck in the middle of your work... Need some advice from an expert?



knittingquery@bergeredefrance.com

From Monday to Friday, during office hours

CHECK YOUR TENSION

Before you start working on a pattern, make sure that the end-result will be perfect by making a swatch.

You've got to make sure that your knitting tension is exactly the same as the tension in our pattern. If it isn't, your garment is likely to be too big or too small.

HOW TO MAKE A SWATCH ?

Using the yarn, needles, and stitch specified for the pattern, work a square at least 6 in (15 cm) on a side.

Iron the square lightly on the wrong side under a damp cloth or using a steam iron. If the swatch is worked in ribbing, stretch it slightly. With a ruler, count the sts to equal 4 in (10 cm) widthways and 4 in (10 cm) lengthways.

Compare the result with the sample given in our instructions.

Your tension square matches ours !

You can start your knitting, you can be sure your project will have the same dimensions as the grid.

Your sample has more stitches and rows ?

Your knitting is too tight. Make another swatch with needles one size larger.

Your sample has fewer stitches and rows ?

Your knitting is too loose. Make another swatch with needles one size smaller.

When your swatch matches ours, you're ready to follow the instructions.

You can expect to end up with a garment that's just right.

BEWARE: It is important to achieve an exact number of stitches for the design to fit correctly. However, the number of rows can be adapted depending on the height indicated in cm.



Read the instructions

Before you start knitting we advise you to read through the instructions, trying to imagine all of the steps you will be taking. All patterns are well detailed.

The instructions are given for several sizes. We suggest that you circle or underline the numbers that correspond to the size you intend to make. If there's only one number, it applies to all the sizes.

BASIC KNITTING STITCHES

1/1 rib

Cast on an uneven number of stitches.

Row 1 : knit 1, purl 1, and repeat these 2 stitches to the last stitch, knit 1.

Row 2 and subsequent rows : purl over the purl stitches, knit over the knit stitches.

Repeat these 2 rows.

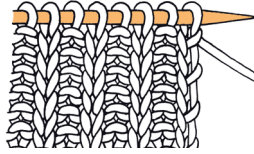

2/2 rib

Cast on a multiple of 4 stitches + 2 (e.g., 22 stitches).

Row 1 : knit 2, purl 2, and repeat to the last stitches, knit 2.

Row 2 and subsequent rows : purl over the purl stitches, knit over the knit stitches.

Repeat these 2 rows.

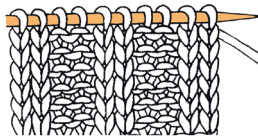

Seed or moss stitch

Cast on an uneven number of stitches.

Row 1 : knit 1, purl 1, repeat these 2 stitches.

Row 2 and subsequent rows : purl over knit stitches, knit over purl stitches.

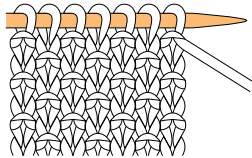

Corn stitch

Cast on an uneven number of stitches.

Row 1 : knit 1, purl 1, repeat these 2 stitches, ending with knit 1.

Row 2 : purl over purl stitches, knit over knit stitches.

Row 3 : purl over knit stitches, knit over purl stitches.

Row 4 : purl over purl stitches, knit over knit stitches.

Repeat these 4 rows.

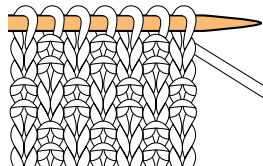

Yarn forward

By bringing the yarn forward you add a stitch and make an eyelet.

Bring the yarn in front of the work then over the right-hand needle.

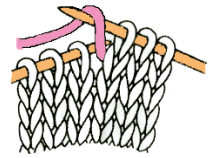

Work the next stitch on the left-hand needle. The yarn forward loop forms an extra stitch with a hold at its base on the right-hand needle.

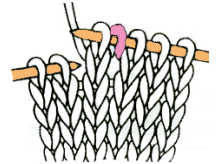

Next row : When you come to the yarn forward loop, purl it as you would any other stitch; you now have 1 extra stitch.

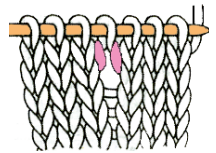

Knit 2 together

Put the right needle through the 2nd then the 1st stitch on the left hand needle.

Knit the 2 stitches together (wrap yarn around right hand needle and pull through the 2 stitches on the left needle).

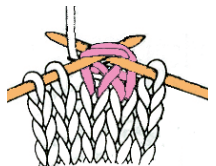
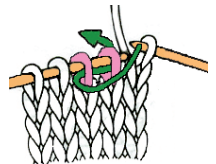

By knitting 2 stitches together you will have 1 less stitch on the needle..

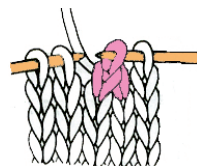

Slipped stitch

With the yarn at the back of the work, insert the right-hand needle into the next stitch from right to left, as if to purl. Slip the stitch on to the right-hand needle and continue working as given.

Next row : Purl the slipped stitch.

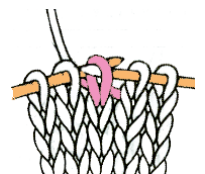

Single decrease

Slip a stitch on to the right-hand needle as if to knit.
Knit the next stitch.

Using the left-hand needle, pass the slipped stitch over the stitch you just worked.

After working a single decrease, you have 1 less stitch on the needle.



Double decrease

Slip a stitch on to the right-hand needle as if to knit.
Knit the next 2 stitches together.

Using the left-hand needle, pass the slipped stitch over the 2 stitches you just worked.

After working a double decrease, you have 2 fewer stitches on the needle.

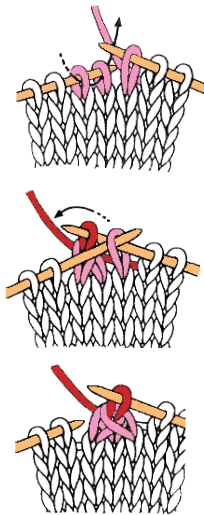

Twisted knit stitch

Knit the stitch, inserting the needle through the back loop to twist the new stitch.

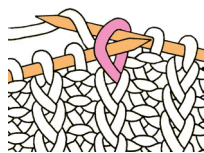

Twisted purl stitch

Purl the stitch, inserting the needle under the back loops to twist the new stitch.



Nonstitch or suppressed stitch

Sometimes, the number of stitches varies from row to row in a pattern; the nonstitches or suppressed stitches are represented by black squares on the chart. When you follow the chart, do not try to work the black squares but go directly to the next square.

Working in reverse

When instructed on the front of a garment, for example a jacket, to work the other front in reverse. If you increased or decreased at the beginning of a right side row on the first front you must increase or decrease at the end of the right side row on the second front at the same measurement. The positions of the stitches used will also be reversed, if you ended with a ribbed section for a border on the first front you will start with the ribbed section on the second front. However the pattern should remain the same (do not reverse a cable twist for example).

Double decrease slip slip knit

Slip 2 stitches as if to knit. Knit 1.
Pass the 2 slipped stitches over the stitch just worked..

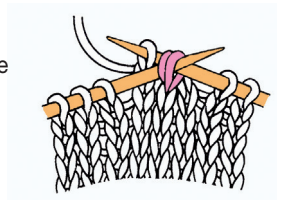

Raglan decreases

This method of decreasing is always used for Raglan sleeves. It forms a line of slanting stitches parallel with the seam. The decrease is worked with the right side facing, one or more stitches from the edge.

The example shows decreases 1 stitch from the edge :

At beginning of row, with right side facing, knit 1, slip 1, knit 1, pass slipped stitch over (See above).

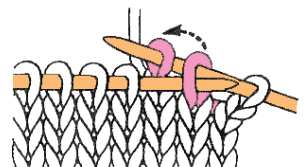

Continue the row as indicated. When 3 sts are left on the left-hand needle, knit the next 2 sts together (see knit 2 together, page 7), knit the last stitch.

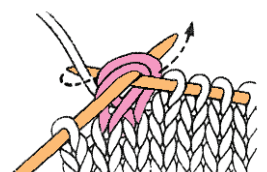

Increases within a row

When you need to increase a stitch in a row you will need to work twice into one stitch.

Put your right needle through the loop of the stitch below the current stitch on your left needle, knit into this stitch.

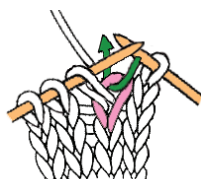

Work the stitch on your left needle as normal.

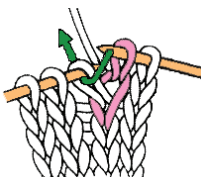

You will have one more stitch.

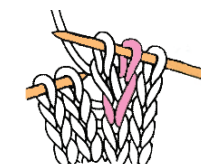

Increases 1 stitch in from edge of row

These increases are always done on the right side of work, 1 stitch in from the edge.

At the beginning of the row, on the right side of work, knit 1 stitch, put the right needle under the horizontal thread before the first stitch on left needle.



Put this strand onto the left needle.

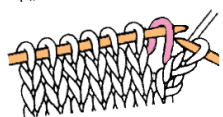

Knit into the back of this loop to twist it.



This prevents a gap forming at the bottom of the increased stitch. Continue along the row.

At the end of the row, on the right side of work, work until 1 stitch remains on left needle, pass right needle through the back of the horizontal thread between stitches and place on left needle.

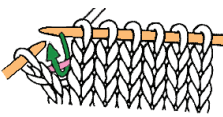

Knit this stitch as normal then knit last stitch.

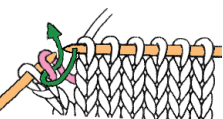

Increases of one stitch or more at end of work

Wrap yarn around the needle at the beginning of the row as many times as you need stitches. If you are increasing at each end you will also need to do at the end of the row.

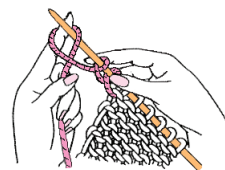

Work these stitches as knit or purl in the pattern required.

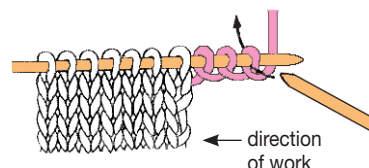

Stretch cast-on

Short Row Shaping Short rows are rows which are not worked in their entirety, this gives a curve to the work as more rows are completed on one side than the other. They can be used on just one side of work or both sides, creating a gentle slope instead of the stepped edge created by casting off a series of stitches.

When told to turn the work during the progress of a row you will not work the remaining stitches on the left hand needle.

To avoid creating a hole when you turn the work, after turning, with the yarn at the front of work (as if about to purl), slip the 1st stitch on the left hand needle onto the right hand needle as if to purl, then take yarn back to back of work (called a wrap) & work the remaining stitches as normal.

When you have finished the short row shaping and need to knit across the whole row you need to knit together the wrap & the next stitch. Take the wrapped stitch back over the top of next stitch then knit both together.

Stretch cast-on

Take a ball of yarn in a contrasting colour and cast on half the required number of stitches plus 1 extra.

For example : If the pattern tells you to cast on 45 stitches, using the contrasting yarn cast on $\frac{45 + 1}{2} = 23$ stitches.

Now, using the yarn you intend to work the pattern with, work as follows :

Row 1 : * knit 1, bring yarn forward under the needle, yarn over *. Repeat from * to *. End with knit 1.

Row 2 : Slip the first stitch as if to purl on to the right-hand needle, *pass yarn to back, knit 1 (= yarn forward loop from previous row), bring yarn forward, slip next stitch as if to purl *. Repeat from * to *.

Row 3 : * knit 1, yarn forward, slip 1 stitch as if to purl, pass yarn to back *. Repeat from * to *. End with knit 1. Continue working in 1/1 rib, beginning Row 1 with purl 1. After completing the ribbing, pull out the contrasting yarn.

Casting off stitches

1) To form armholes or collar

You must cast off stitches at the beginning of rows:

On the right side of work, slip 1 stitch onto the right needle as if to purl. Knit the following stitch.

Using the left needle pass the slipped stitch over the top of the 2nd stitch on the right hand needle. You have cast off 1 stitch.

Knit the next stitch and pass stitch on right needle over the top, you have cast off a 2nd stitch. Repeat this step for the required number of stitches. On the following row, on the wrong side of work, cast off in the same way but work the stitches as purl stitches.

On the following row, cast off the next number of stitches indicated in the pattern to obtain a sloped edge.

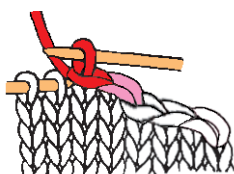
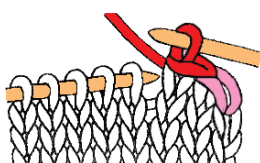
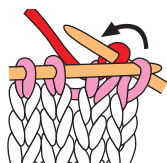
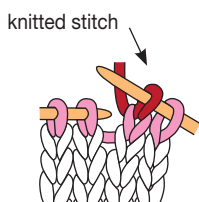

2) When work is complete, to cast off all stitches.

Start to cast off as for casting off at the beginning of row: Slip the 1st stitch, knit the following stitch. With the left needle, pass the slipped stitch over the top of the knitted stitch.

Knit the next stitch and with the left needle, pass the 1st stitch on needle over the top of the current stitch. One stitch remains on right needle.

Repeat this sequence until all stitches from the left needle have been worked and only one stitch remains on right needle. Cut thread 10 cm from work and pull through remaining stitch using needle.

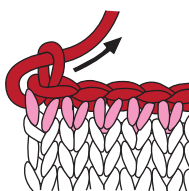
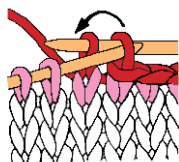

Small buttonholes

For a small buttonhole, one stitch is sufficient to make a buttonhole:

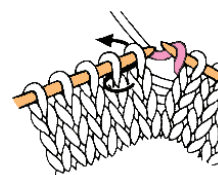

Yarn over needle, then knit 2 together. On the next row work the yarn over needle as normal.

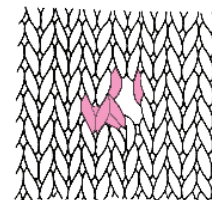

Buttonholes

1st row : Work to where the buttonhole should be, cast off the number of sts indicated in the pattern and work to end of row.

2nd row : Work to cast off sts, cast on the same number of sts as 1st row and work to end of row.

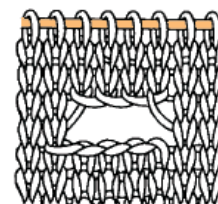

No-cut buttonholes

Using a sewing needle, pick up the horizontal strand of the stitch where you want to place the buttonhole, pull it up and attach it 2 rows higher with a few little stitches on the wrong side of the work. Repeat with the horizontal strand below the first strand, and attach it in the same way 2 rows down.

Pattern stitches

Instructions for pattern stitches are always given row by row, as well as in chart form, with each square on the chart representing 1 stitch and 1 row.

The accompanying legend explains the terms and matches the symbols to the stitches. The chart shows the right side of the work, it is not always possible, however, to include all the subtleties of a pattern stitch in a chart. For that reason, we advise you to always read the row-by-row instructions, even if you prefer to use a chart.

Knit over knit and purl over purl is an instruction often used for ribbing and pattern stitches.

Cables

It is easy to work narrow cables over 2 stitches :

Right cross 2 : Passing in front of the work, knit the 2nd st on the left-hand needle then knit the first stitch; slip both stitches on to the right-hand needle at once.

Left cross 2 : Passing behind the work, knit the 2nd st on the left-hand needle then knit the first stitch as usual; slip both stitches on to the right-hand needle at once.

A cable made up of 3 or more stitches requires the use of a cable needle.

Cable 4 left (front) :

Slip 2 stitches on to a cable needle in front of work, knit 2, then slip the 2 stitches from the cable needle on to the left-hand needle and knit 2.

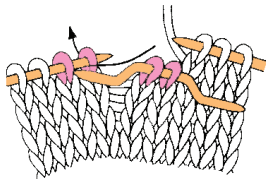

Cable 4 right (back) :

Slip 2 stitches on to a cable needle at back of work, knit 2, then slip the 2 stitches from the cable needle on to the left-hand needle and knit 2.

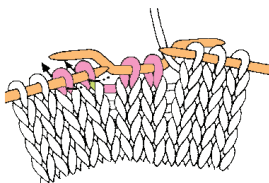

Picking up stitches

When the different sections of the garment are completed, you may need to pick up stitches at the edge of your work, for example on the collar or front borders

To pick up the stitches knit wise, put needle through the middle of each stitch on the last row and pick up the loop. When you are picking up stitches on rows where there are more rows than stitches required work through 2 or 3 rows then skip 1 row to obtain the number of stitches required in the pattern.

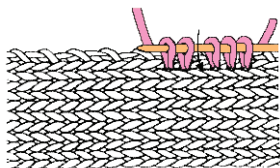
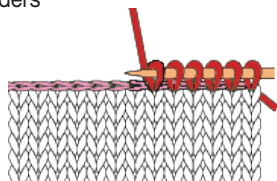

Backstitched seam

Place the 2 pieces right sides together. Thread a tapestry needle with the matching yarn, insert the needle through both thicknesses, matching stitch for stitch, and bring the needle out 2 rows further along.

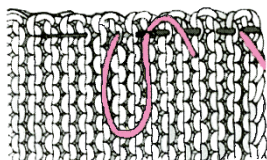

Grafting

This technique is widely used in European patterns, but is not so popular among UK and US knitters. When you have completed the sections, do not cast off, but leave the stitches on a spare needle.

Thread a tapestry needle with the matching yarn. Work with right side facing. Place the 2 spare needles together.

Insert the tapestry needle through the centre of the first stitch on the front needle as if to purl (leave the stitch on the needle),

– and bring the tapestry needle out at the centre of the first stitch on the back needle as if to knit (leave the stitch on the needle),

*bring the tapestry needle through the centre of the first stitch on the front needle again as if to knit and slip off the stitch,

– Insert the tapestry needle through the centre of the next stitch on the front needle as if to purl (leave the stitch on the needle),

– bring the tapestry needle out at the center of the next (first) stitch on the back needle again as if to purl and slip off the stitch,

– Insert the tapestry needle through the centre of the next stitch on the back needle as if to knit (leave the stitch on the needle)*, maintaining an even tension. Repeat the movement until the seam is complete.

Work all the free stitches into the seam one by one and let the stitches drop off the spare needles as they are grafted together.

The finished seam will look identical to a row of knitting.

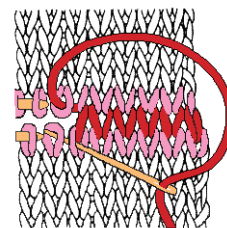
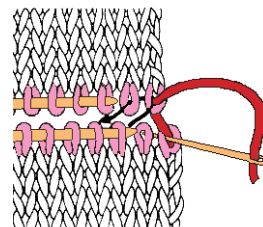

Invisible seam

Following the sketch, working with the 2 pieces to be joined, pick up the horizontal thread between the first and second stitches and pull firmly to bring the edges together and make the join invisible. If the edge is very uneven, work the thread between the second and third stitches.

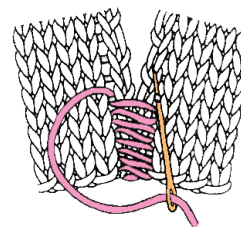

You may also use an invisible seam to join at the shoulder. In that case, pick up the 2 upright strands of a stitch 1 row in from the edge.

Fair Isle

Fair Isle and contrasting colour patterns.

These patterns are worked in stocking stitch using several colours to make a design shown on a chart.]

Each square on the chart represents 1 stitch and 1 row. A legend accompanying the chart indicates the colours. Read the chart beginning at the bottom row, from right to left for the right side of the work, and from left to right for the wrong side rows.

KNITTED PATTERNS

Various techniques are used according to the complexity of the pattern.

- When the motifs of the design are small and close together, you may let the yarn not in use run loosely at the back of the work. Make sure that you don't pull the yarn taut or it will pucker the pattern.
- When the motifs are far apart or very wide, pass the yarn not in use behind the work attaching it along with the one that is in use : hold the yarn not in use in your left hand, then work a stitch passing the right-hand needle under that yarn but taking care not to actually knit the yarn. Repeat this movement every other stitch.
- When the motifs are very large or use several colours, do not try to pass the yarn at the back of the work. Instead, use several balls of each colour, as needed, using the intarsia technique. Each time you change yarn colour, make sure that you twist the yarns loosely at the back of the work to avoid forming holes in the texture.

In all three cases, take care to work evenly, especially where the colours change and stitches tend to be loose.

EMBROIDERED PATTERNS

Embroidery can be used to advantage instead of knitted patterns when the motifs are made up of relatively few stitches.

This technique avoids the problems of disposing of extra yarns at the back of the work. For embroidery, form open chain stitch with a tapestry needle, working from right to left.

Bring the needle from wrong side to right side at the base of the first stitch, insert the needle from right to left under both strands of the stitch above the one being worked (see sketch no. 1), then insert the needle again at the base of the stitch being worked and bring it out at the base of the next stitch (see sketch no. 2).

Use this technique to embroider the number of stitches indicated. After the last stitch, bring the needle out at the base of the row above. Turn the work to start again from right to left.

Sketch no 1

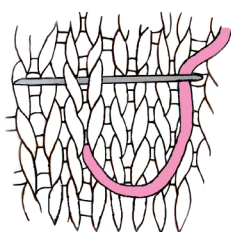

Sketch no 2

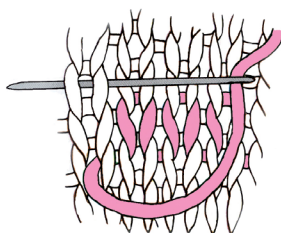

Grafting a border

When the border is finished, work a few rows of stocking stitch using a contrasting yarn.

Take the work off the needle and press the stocking stitch section with a warm iron under a damp cloth to prevent it from unraveling. Pin the border to the finished garment, matching the stitches. Unravel all but the last row of stocking stitch. Now graft the stitches, waving the tapestry needle in and out, and unravel the last row of stocking stitch as you go. Bring the needle from back to front through the centre of the second stitch, work a back stitch into the first stitch and bring the needle out again at the centre of the third stitch; now work a backstitch again into the second stitch and continue thus with backstitching as far as the last stitch.

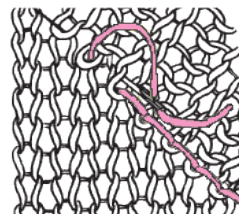

Chainstitch shoulder seam

CHAINSTITCH SHOULDER SEAMS

or 3 needles cast off or 3 needles bind off

Leave the remaining shoulder stitches on a spare needles. Place back and front with wrong sides together.

Using a third needle, knit together the first stitch from the front needle with the first from the back needle, and repeat with the second stitch from each needle. You now have 2 stitches on the right-hand needle.

Pass the first stitch over the second, as in casting off. Continue thus until you have cast off all the shoulder stitches. The result is a chain that shows on the right side and a shoulder seam that will not go out of shape. To obtain an invisible seam on the right side, place back and front with right sides together.



BASIC CROCHET STITCHES

Chain stitch (ch or ch st)

The first stitch in crochet. Make a loop. Insert the hook in the loop. * Pass the hook under the yarn for a yarn over (yo), and pull the yo through the loop = 1 ch st. Rep from * to work as many ch sts as needed.

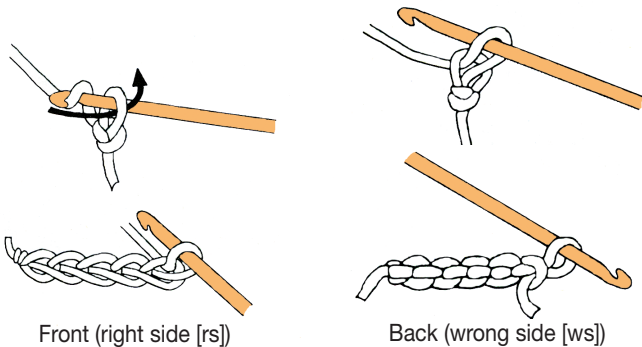

Stitch (sl st)

Insert the hook into a stitch, yo and pull through the loop on the hook in a single movement.

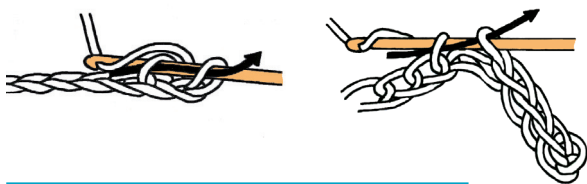

Single Crochet (

UK: Double Crochet) = sc (uk: dc)

Insert the hook into a stitch, yo and draw up loop, yo and through both loops on hook.

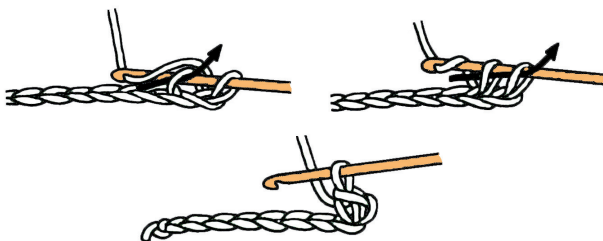

Crab Stitch (sc (uk: dc) worked from left to right)

Beg at left edge: * insert hook into a stitch, yo and draw up lp, yo and through both lps on hook *, rep from * to *, inserting hook into preceding st..

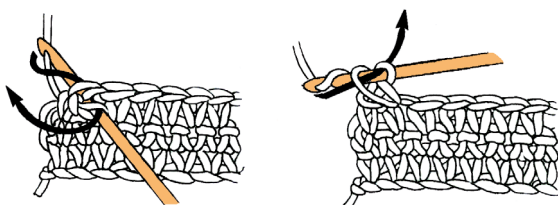

Half Double Crochet

(UK: Half Treble) = hdc (uk: half tr)

Yo, insert the hook into a stitch, yo and draw up loop, yo and through all 3 loops.

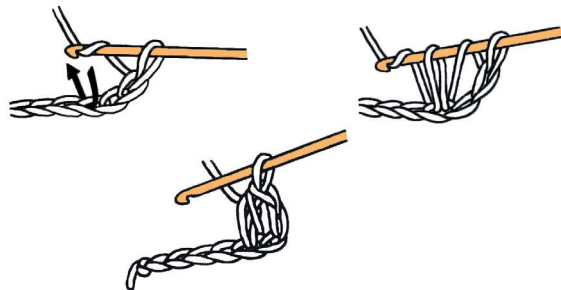

Double Crochet

(UK: Treble) = dc (uk: tr)

Yo, insert the hook into a st, yo and draw up loop, yo and through first 2 loops on hook, yo and through remaining 2 loops.

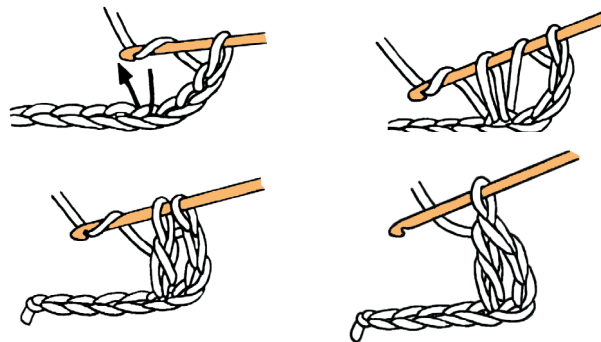

Treble (UK: Double Treble)

= tr (uk: dbl tr)

Yo twice, insert the hook into a stitch, yo and draw up loop, yo and through first 2 loops on hook, yo and through 2 loops on hook, yo and through remaining 2 loops.

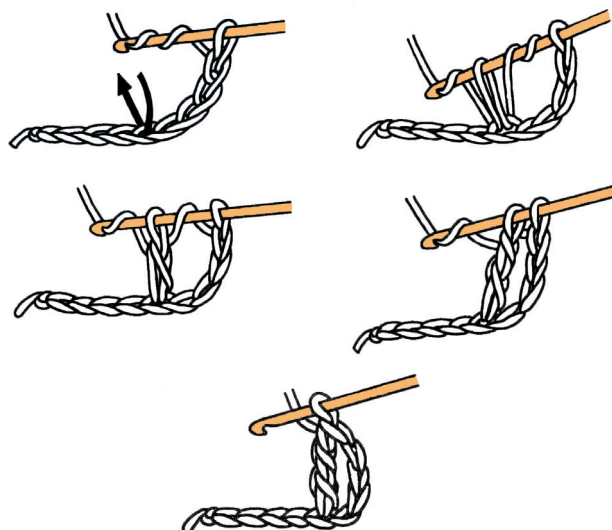

Double Treble

(UK: Triple Treble) = dbl tr (uk: tr tr)

Yo 3 times, insert the hook in a stitch, yo and draw up loop, yo and through first 2 loops on hook, yo and through 2 loops on hook, yo and through 2 loops on hook, yo and through remaining 2 loops.

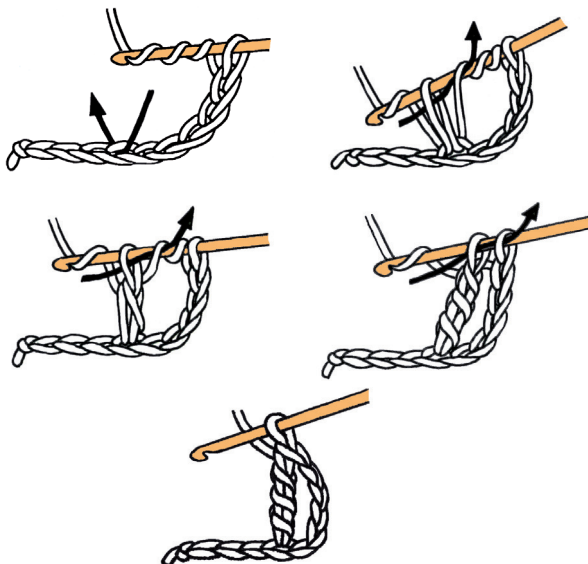

Beginning with a round

Wind the yarn around the tip of your index finger, slip the hook through the loop, yo and draw up lp, yo and through the loop as shown, then work as many dc as indicated. To end the first round, work a sl st over the first dc and pull gently but firmly on the end of yarn to close up the initial ring..

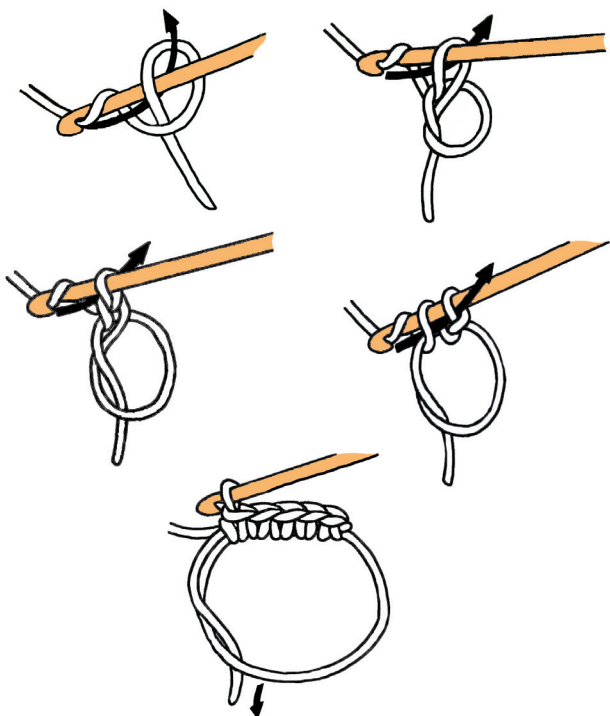

2 Single Crochet Together (UK: 2 Double Crochet Together) = 2 sc tog (uk: 2 dc tog)

Leaving last loop of each st on the hook, work incomplete sc as follows: Insert hook into a st, yo and draw up loop, insert hook into next st, yo and draw up loop, yo and through all remaining 3 loops.

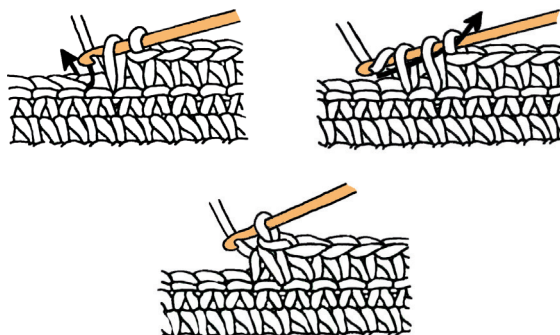

3 single crochets together (3 sc tog) [3 double crochets together : 3 dc tog (UK)]

Leaving last loop of each stitch on the hook, work incomplete sc as follows; insert hook in a stitch, yo and draw up loop, insert hook in next stitch, yo and draw up loop, insert hook in next stitch, yo and draw up loop, yo and through all remaining 4 loops at once.

2 Double Crochets Together (UK: 2 Trebles Together) = 2 dc tog (uk: 2 tr tog)

Leaving last loop of each st on the hook, work incomplete dc as follows : yo, insert the hook into a st, yo and draw up loop, yo and through first 2 loops on hook, yo, insert hook into next st, yo and draw up loop, yo and through first 2 loops, yo * and through all 3 remaining loops.



3 Double Crochets Together (UK: 3 Trebles Together) = 3 dc tog (uk: 3 tr tog)

As for 2 dc tog as far as *, then insert hook into next st, yo and draw up loop, yo and through 2 loops on hook, yo and through all 4 remaining loops.

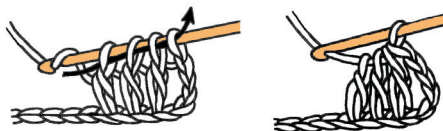

2 or 3 Double Crochets Together (UK: 2 or 3 Trebles Together) = 2 or 3 dc tog (uk: 2 or 3)

As for dc tog (tr tog), but beg by working yo twice.

1 CAPE



Quality:
FILÉCO



Needles:
**5.0 mm needles 50 cm (19½ in) long,
or circular needles**



Accessories:
**Brown faux leather fastener ref. 30806
Brown sewing thread (not sold)**

One size

Quality FILÉCO	Number of balls
Ecobeige (A) 54634	7
Ecoprune (B) 54639	5
Ecorose (C) 54726	4
Ecoocre (D) 54723	1

Stitches used

STOCKING ST (St st), using 5.0 mm needles.

Row 1 (RS): knit.

Row 2: purl.

Rep these 2 rows.

Follow Chart for stripe sequence.

Tension/Gauge

To achieve a good result it is essential to make a tension square (see "Check Your Tension" instructions at beginning of book).

16 sts & 20 rows over Striped St st using 5.0 mm needles = 10 cm (4 in) square.

To make

BACK:

Using col C cast on **175** sts. Starting with a knit row cont in striped St st foll **Chart No 1** (make sure to cross yarn at back of work when changing colour).

When work measures **60** cm (**23½** in) [**120** rows] total, after the final row of the Chart, cast off all sts.

RIGHT FRONT:

Using col C cast on **90** sts. Starting with a knit row cont in striped St st foll **Chart No 2** (make sure to cross yarn at back of work when changing colour).

When work measures **70** cm (**27½** in) [**140** rows] total, after the final row of the Chart, cast off all sts.

LEFT FRONT:

Work as for Right Front.

FINISHING:

Join the top of the 2 Fronts together, making a seam over 6 rows, 3 sts from the edge (= red lines on Chart no 3).

Then sew the top of the Back to the Fronts (= blue lines on diagram).

Prepare fastener: To aid sewing, pierce the section of the fastener that will be sewn to garment at regular intervals (using a sewing machine or a sewing needle).

Following the diagram, sew (= white dots on diagram) the loop section to the Right Front, then the other section in line on the Left Front.

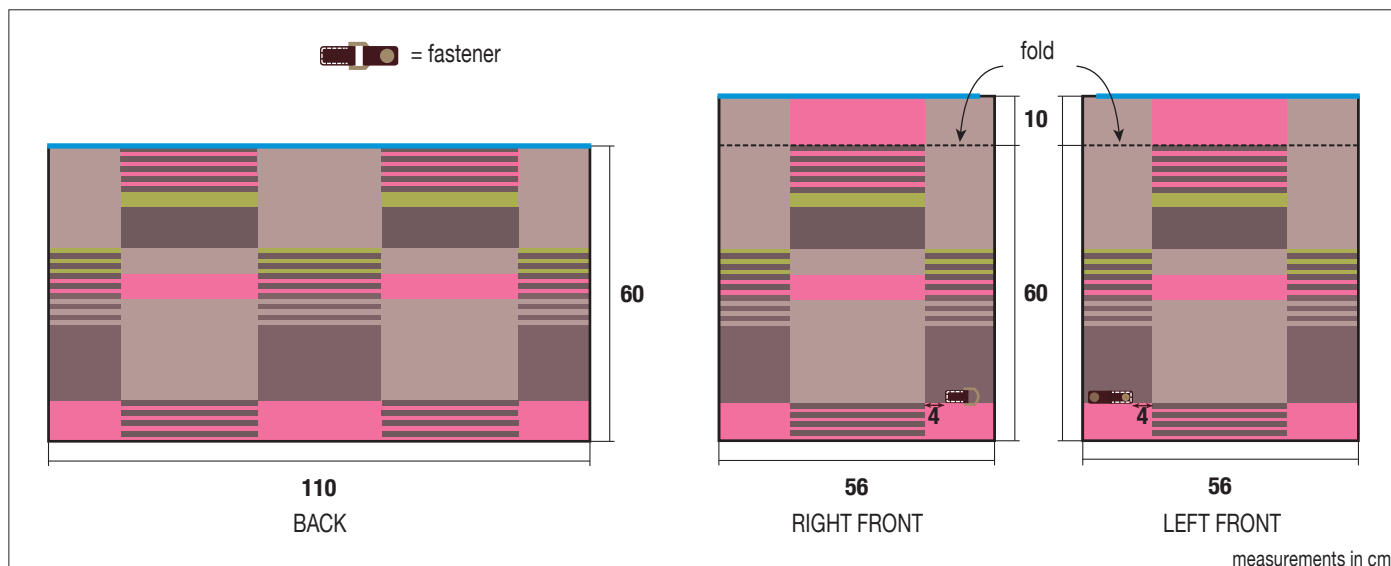
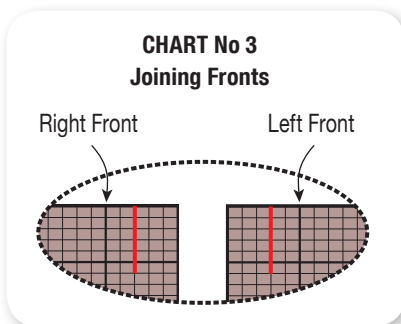

measurements in cm

CHART No 2 - FRONTS

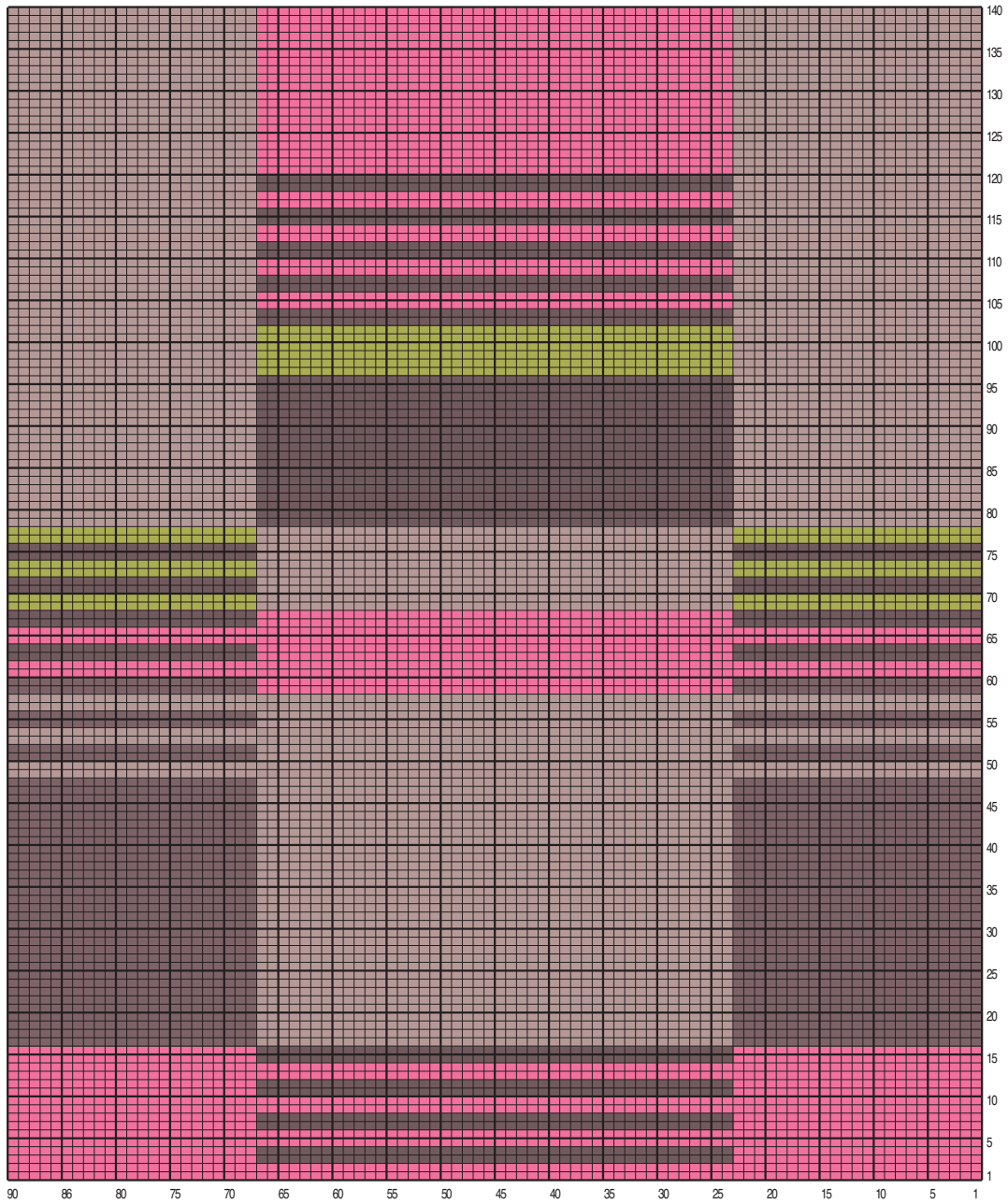

- = K1 on RS, P1 on WS using Col C
- = K1 on RS, P1 on WS using Col B
- = K1 on RS, P1 on WS using Col A
- = K1 on RS, P1 on WS using Col D

CHART No 1 - BACK

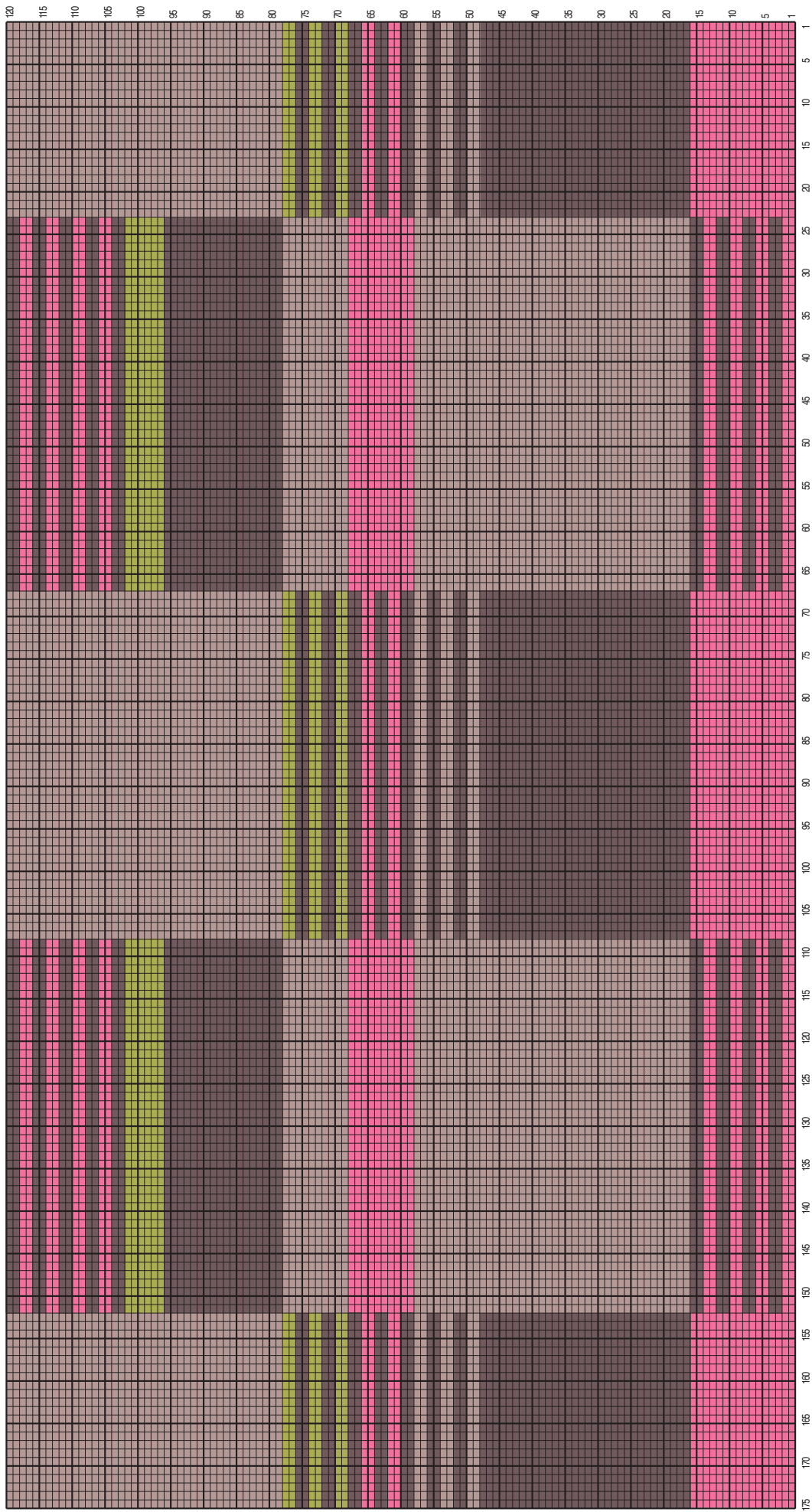

- = K1 on RS, P1 on WS using Col C
- = K1 on RS, P1 on WS using Col B
- = K1 on RS, P1 on WS using Col A
- = K1 on RS, P1 on WS using Col D

ROUND NECK LACEWORK SWEATER



Quality: **FILÉCO**
Needles: **4.0 mm & 5.0 mm**

Sizes		S	M	L	XL	XXL
Quality FILÉCO		Number of balls				
Ecobrique	54628	9	10	10	11	12

Stitches used

2/2 RIB, using 4.0 mm needles.

STOCKING ST (St st), using 5.0 mm needles.

LACE STITCH, using 5.0 mm needles. Follow Chart for size being made.

Tension/Gauge

To achieve a good result it is essential to make a tension square (see "Check Your Tension" instructions at beginning of book).

16 sts & 20 rows over St st using 5.0 mm needles = 10 cm (4 in) square.

To make

BACK:

Using 4.0 mm needles CO **74-78-86-94-102** sts.

Row 1 (RS): *k2, p2* rep from *to* ending with k2.

Row 2: *p2, k2* rep from *to* ending with p2.

These 2 rows form 2/2 rib, cont as est until work measures **5 cm (2 in) [12 rows]** total, **but** on the last row **for sizes S, L, XL & XXL** dec 1 st; **for size M** inc 1 st.

Change to 5.0 mm needles & starting with a knit row cont in St st on the **73-79-85-93-101** sts until work measures **35-36-36-37-38 cm (13¾-14-14½-15 in) [72-74-74-76-78 rows]** total.

Armholes:

Cast off at the beg of every row as foll: 3 sts **2-2-2-2-4** times, 2 sts **2-4-4-6-4** times. **63-65-71-75-81** sts rem.

Next row (RS-dec): k2, k2tog, work to last 4 sts, sl 1, k1, pss0, k2.

Rep this dec on every foll RS row **3-2-3-3-4** more times.

Cont on the rem **55-59-63-67-71** sts until work measures **52-54-56-58-60 cm (20½-21¼-22-22¾-23½ in) [106-110-114-118-122 rows]** total.

Shoulders & Neck:

Next row (RS): Cast off **5-5-5-6-6** sts, work **12-13-14-14-15** sts, cast off the central **21-23-25-27-29** sts, work to end.

Next row (WS): Cast off **5-5-5-6-6** sts, work to cast off sts, put rem sts on a stitch holder. Work will now be completed in 2 sections.

***Next row (neck edge):** Cast off 2 sts, work to end.

Cont to cast off at the shoulder edge on every alt row as foll: **5-5-6-6-6** sts **2-1-2-2-1** times, then **0-6-0-0-7** sts **0-1-0-0-1** times.*

With WS facing pick up sts left on stitch holder & work from *to* above.

FRONT:

Using 4.0 mm needles CO **74-78-86-94-102** sts. Work in 2/2 rib as for back until work measures **5 cm (2 in) [12 rows]** total, but on the last row **for sizes S, L, XL & XXL** dec 1 st; **for size M** inc 1 st.

Change to 5.0 mm needles & work in Lace St following Chart for size being made on the **73-79-85-93-101** sts obtained until work measures **35-36-36-37-38 cm (13¾-14-14½-15 in) [72-74-74-76-78 rows]** total.

Note:

- a k2tog or sl 1, k1, pss0 or p2tog must be accompanied by a yon
- a double decrease must be accompanied by 2 yon's.

Armholes:

Cast off & decrease the armholes as for Back, then cont on the rem **55-59-63-67-71** sts until work measures **45-47-49-51-53 cm (17¾-18½-19¼-20-20¾ in)**.

Neck:

Next row (RS): Work **23-24-25-26-27** sts, cast off the central **9-11-13-15-17** sts, work to end.

Next row (WS): Work to cast off sts, put rem sts on a stitch holder. Work will now be completed in 2 sections.

*Cont to cast off at neck edge on every alt row as foll: 3 sts once, 2 sts once, 1 st 3 times.

Cont on the rem **15-16-17-18-19** sts until work measures **52-54-56-58-60 cm (20½-21¼-22-22¾-23½ in) [106-110-114-118-122 rows]** total.

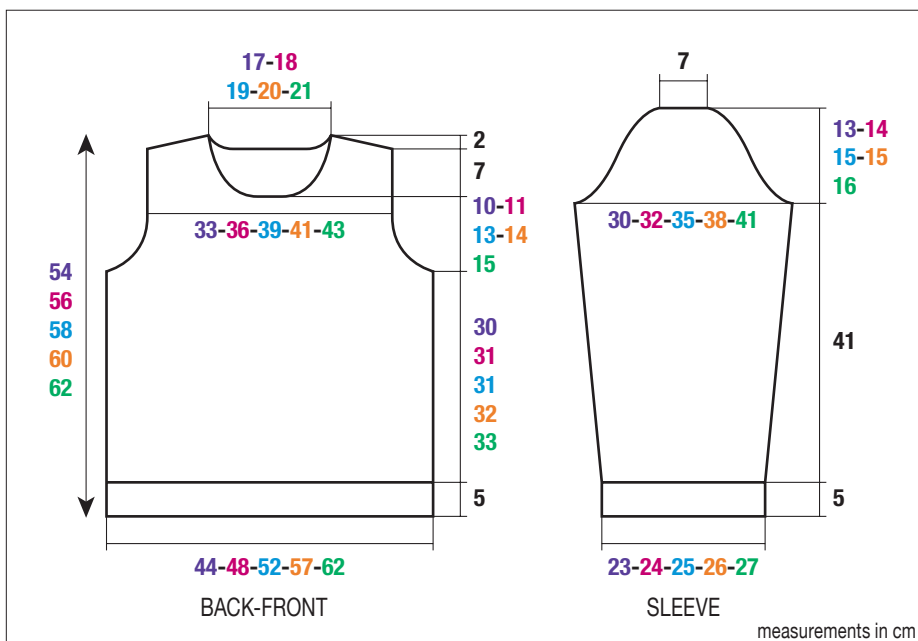

Shoulder:

Cast off at shoulder edge on every alt row as foll: **5-5-5-6-6** sts **3-2-1-3-2** times, then **0-6-6-0-7** sts **0-1-2-0-1** times.

SLEEVES:

Using 4.0 mm needles CO **38-38-42-42-46** sts. Work in 2/2 rib as for back, **but** on the last row **for size M** inc 2 sts; **for size XL** inc 1 st; **for size XXL** dec 1 st.

Change to 5.0 mm needles & starting with a knit row cont in St st on the **38-40-42-43-45** sts obtained for **12-12-10-8-8** rows.

Next row (RS-inc): k2, inc 1, work to last 2 sts, inc 1, k2.

Rep this inc on every foll **12th-12th-10th-8th-8th** row **5-1-4-6-3** more times, then on every foll **0-10th-8th-6th-6th** row **0-5-3-3-7** times.

Cont on the **50-54-58-63-67** sts obtained until work measures **46 cm (18 in) [94 rows]** total.

Top of sleeve:

Cast off at the beg of every row as foll: 3 sts twice, 2 sts **2-2-4-4-6** times. **40-44-44-49-49** sts rem.

Next row (RS – dec): k2, k2tog, work to last 4 sts, sl 1, k1, pssso, k2.

Rep this dec on every foll RS row **8-8-8-7-7** more times. **22-26-26-33-33** sts rem.

Cast off at the beg of every row as foll: 2 sts **2-4-4-4** times, 3 sts **2-2-2-4-4** times, then the rem **12-12-12-13-13** sts.

NECKBAND:

Using 4.0 mm needles CO **86-90-94-98-102** sts. Work in 2/2 rib for **6** rows then leave on a spare needle.

FINISHING:

Join shoulder seams.

Graft neckband around neck edge using back stitch (see: 'Knitting: Stitches/Techniques/Tips'). Then join the ends.

Sew the top of the sleeves into the armholes.

Sew side & sleeve seams.

Secure & weave in all ends.

Note:
The decreases 2 sts in from edge are not shown on Chart.

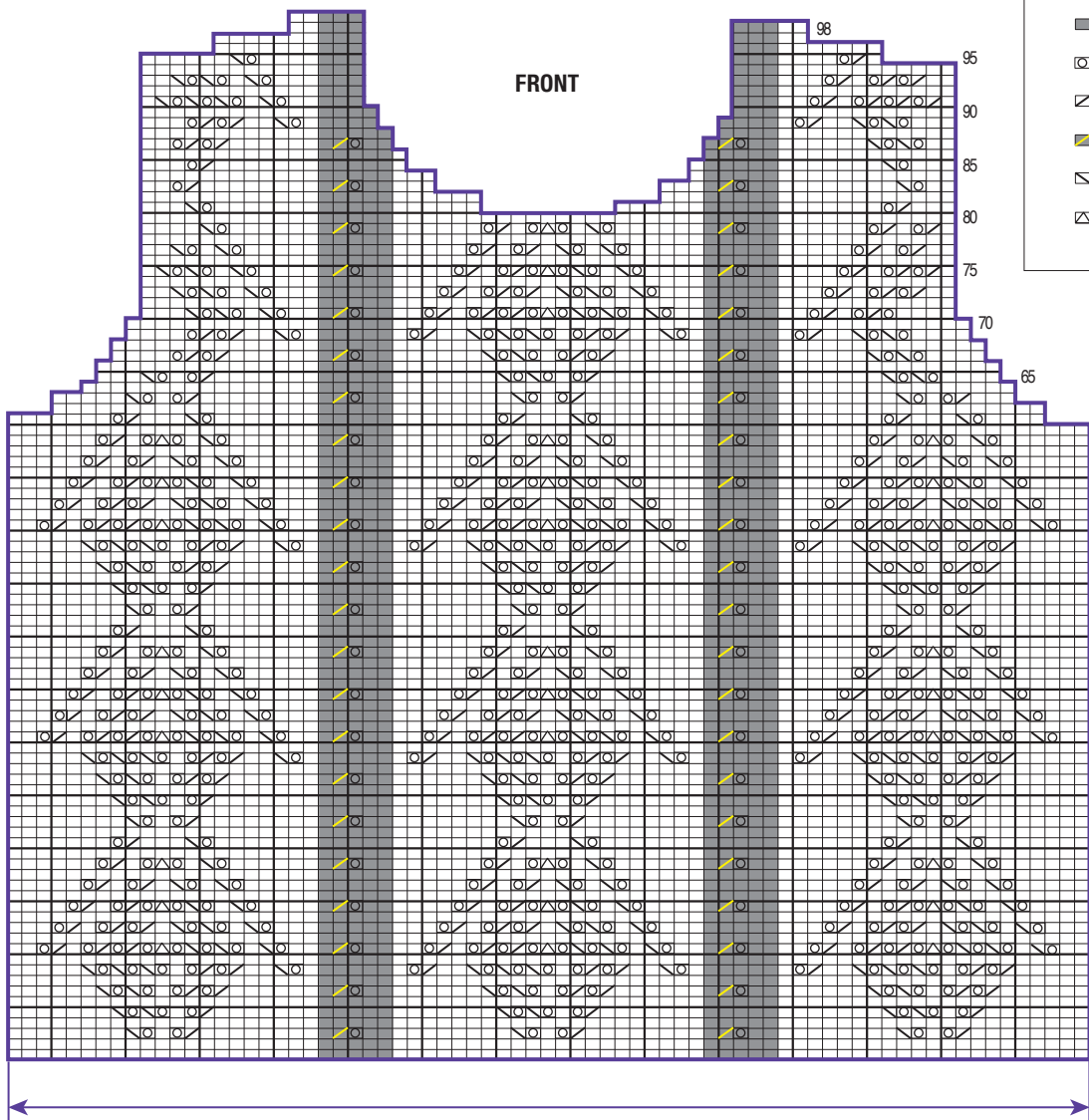

- = K on RS, P on WS
- = P on RS, K on WS
- = yon
- ⊗ = k2tog
- ⊕ = p2tog
- ⊘ = sl 1, k1, pssso
- ⊚ = sl 2, k1, pssso

S = 73 sts

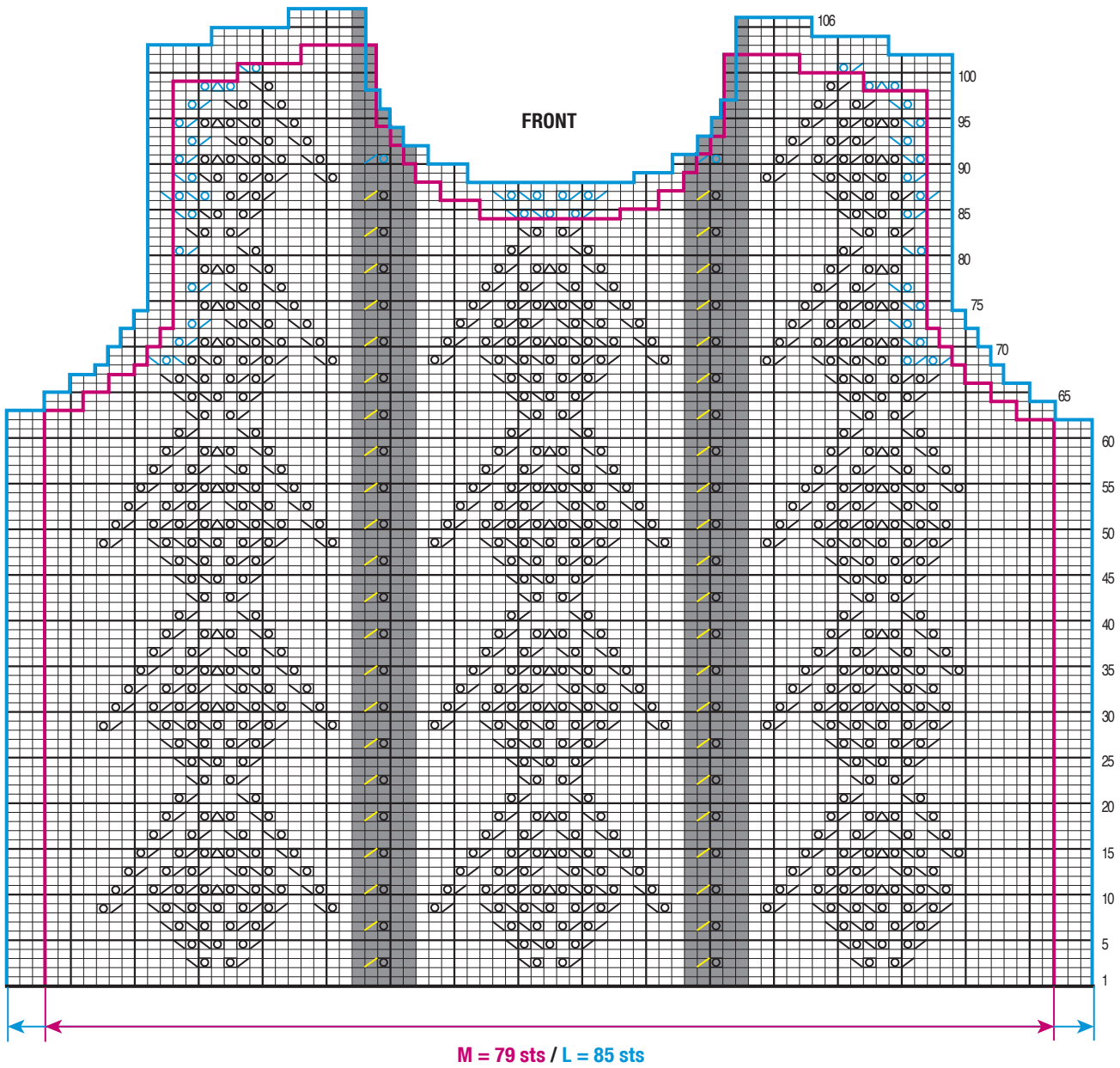

Note:
The decreases 2 sts in from edge are not shown on Chart.

- = K on RS, P on WS
- = P on RS, K on WS
- = yon
- ◻ or ◼ = yon *only for size L*
- ◊ = k2tog
- ◊ = k2tog *only for size L*
- ◊ = p2tog
- ◊ = p2tog *only for size L*
- ◊ = sl 1, k1, pssso
- ◊ = sl 1, k1, pssso *only for size L*
- ◊ = sl 2, k1, pssso
- ◊ = sl 2, k1, pssso *only for size L*

Note:

The decreases 2 sts in from edge are not shown on Chart.

- = K on RS, P on WS
- = P on RS, K on WS
- ⊗ = yon
- ⊙ or ⊚ = yon only for size XXL
- ⊛ = k2tog
- ⊜ = k2tog only for size XXL
- ⊝ = p2tog
- ⊞ = p2tog only for size XXL
- ⊟ = sl 1, k1, pss0
- ⊠ = sl 1, k1, pss0 only for size XXL
- ⊡ = sl 2, k1, pss0
- ⊢ = sl 2, k1, pss0 only for size XXL

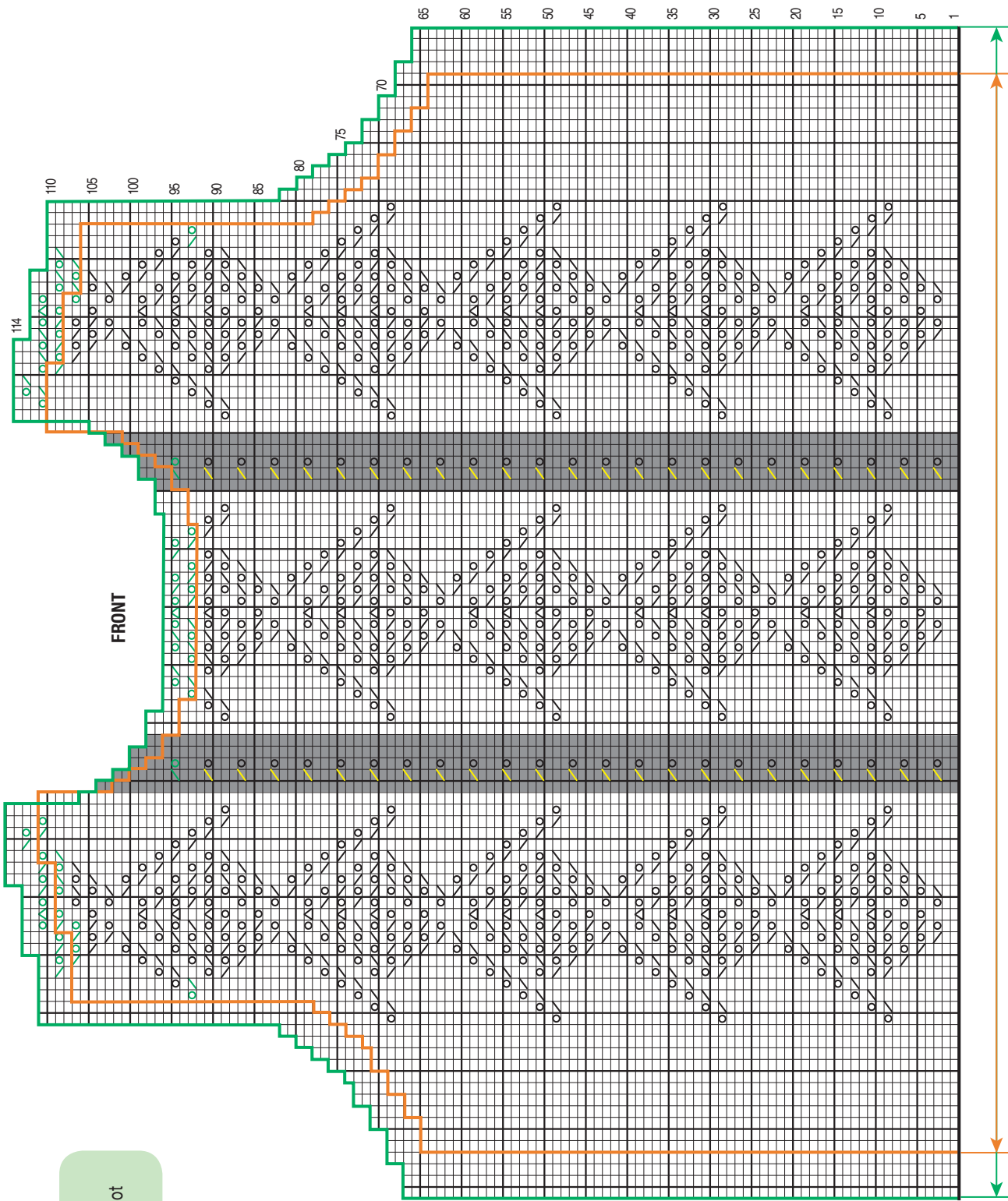

XL = 93 sts / XXL = 101 sts

JACKET WITH HIGH COLLAR



Quality:
FILÉCO

Needles:
9.0 mm



Accessories:
3 brown perforated fasteners ref. 66067 (pk of 2)
Brown sewing thread (not sold)

Sizes		S	M	L	XL	XXL
Quality FILÉCO		Number of ball				
Ecoprune	54639	21	23	25	28	30

Stitches used

The jacket is made using 2 strands of yarn knitted together throughout.

GARTER ST (G.st), using 9.0 mm needles.
Every row knit.

STOCKING ST (St st), using 9.0 mm needles.

Row 1 (RS): knit.

Row 2: purl.

PATTERN STITCH, using 9.0 mm needles.

6 rows G.st

*6 rows St st,

4 rows G.st,

2 rows St st,

4 rows G.st,

6 rows St st,

8 rows G.st*,

Repeat from * to *.

Tension/Gauge

To achieve a good result it is essential to make a tension square (see "Check Your Tension" instructions at beginning of book).

10 sts & 15.5 rows over Pattern stitch using 2 strands of yarn held together & 9.0 mm needles = 10 cm (4 in) square.

10 sts & 13 rows over St st using 2 strands of yarn held together & 9.0 mm needles = 10 cm (4 in) square.

To make

BACK:

Using 9.0 mm needles & 2 strands of yarn held together CO **54-58-62-67-72** sts.

Continue in Pattern st until work measures **44-45-45-46-47** cm (**17¼-17¾-17¾-18-18½** in) [**68-70-70-72-74** rows] total.

Armholes:

Cast off 4 sts at beginning of next 2 rows.

Continue on the remaining **46-50-54-59-64** sts in Pattern st until work measures **62-62-62-68-68** cm (**24¼-24¼-24¼-26½-26½** in) [**96-96-96-106-106** rows] total.

Neck:

Continue in St st for **0-4-6-0-4** rows.

Next row (RS): k**18-19-21-23-25**, cast off the central **10-12-12-13-14** sts **for the neck**, work to end.

Next row (WS): work to cast off sts. Put rem sts on a stitch holder, work will now be completed in 2 sections.

***Next row (neck edge):** Cast off 2 sts, work to end. **16-17-19-21-23** sts rem.

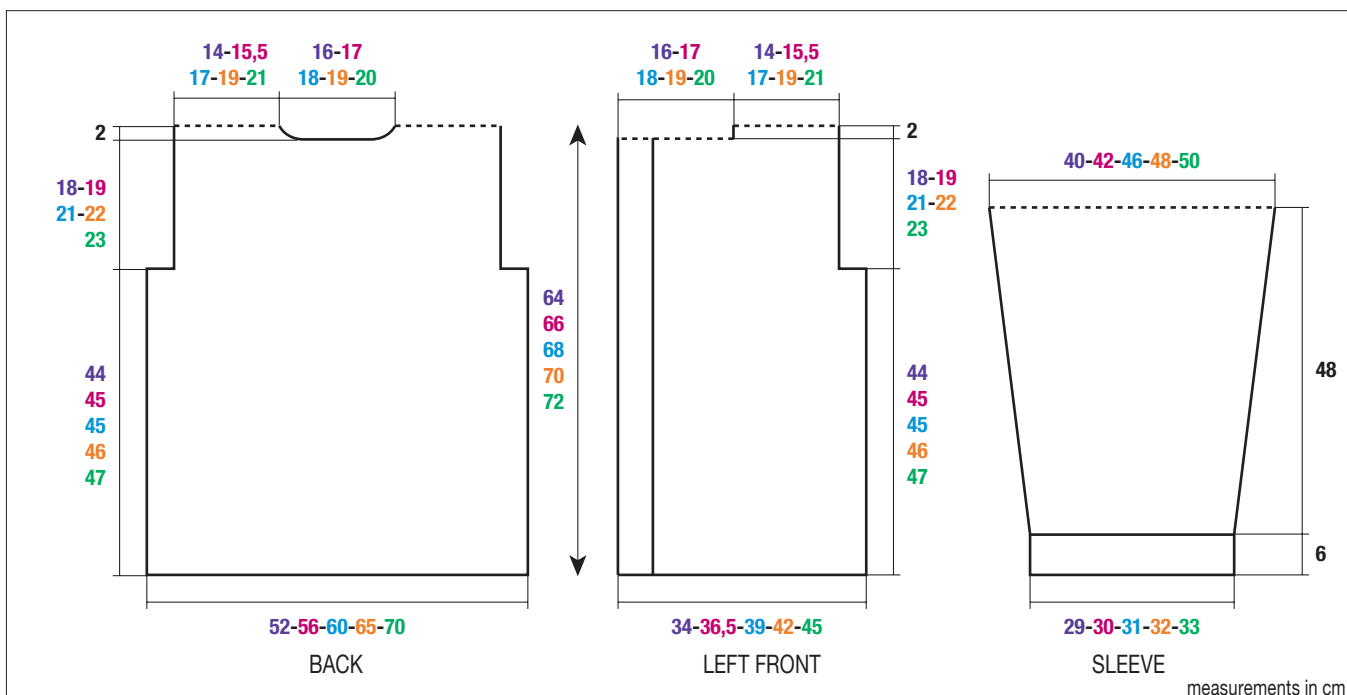

Shoulder:

When work measures **64-66-68-70-72** cm (**25-26-26½-27½-28¼** in) [**100-104-106-110-114** rows] total, leave the remaining **16-17-19-21-23** sts on a spare needle*.

With WS facing pick up sts left on stitch holder & rep from *to* above.

LEFT FRONT:

Using 9.0 mm needles & 2 strands of yarn held together CO **34-37-39-42-45** sts.

Row 1 (RS): Work **30-33-35-38-41** sts in Pattern st, **4** sts in G.st for the border.

Row 2: Work **4** sts in G.st for the border, **30-33-35-38-41** sts in Pattern st.

These 2 rows set the pattern, continue as established until work measures **44-45-45-46-47** cm (**17¼-17¾-17¾-18-18½** in) [**68-70-70-72-74** rows] total.

Armholes:

Cast off **4** sts at beginning of next RS row.

Continue on the remaining **30-33-35-38-41** sts in Pattern as set until work measures **62-62-62-68-68** cm (**24¼-24¼-24¼-26½-26½** in) [**96-96-96-106-106** rows] total.

Neck:

M-L & XXL only

Continue in St st with the G.st border for **4-6-4** rows.

All sizes

Next row (RS): k**16-17-19-21-23**, place the remaining **14-16-16-17-18** sts at the border edge on a spare needle, turn work and cont on the remaining **16-17-19-21-23** sts.

Shoulder:

When work measures **64-66-68-70-72** cm (**25-26-26½-27½-28¼** in) [**100-104-106-110-114** rows] total, leave the remaining **16-17-19-21-23** sts on a spare needle.

RIGHT FRONT:

Using 9.0 mm needles & 2 strands of yarn held together CO **34-37-39-42-45** sts.

Row 1 (RS): Work **4** sts in G.st for the border, **30-33-35-38-41** sts in Pattern st.

Row 2: Work **30-33-35-38-41** sts in Pattern st, **4** sts in G.st for the border.

These 2 rows set the pattern, continue as established until work measures **44-45-45-46-47** cm (**17¼-17¾-17¾-18-18½** in) [**68-70-70-72-74** rows] total.

Armholes:

Cast off **4** sts at beginning of next WS row.

Continue on the remaining **30-33-35-38-41** sts in Pattern as set until work measures **62-62-62-68-68** cm (**24¼-24¼-24¼-26½-26½** in) [**96-96-96-106-106** rows] total.

Neck:

M-L & XXL only

Continue in St st with the G.st border for **4-6-4** rows.

All sizes

Next row (RS): place the first **14-16-16-17-18** sts at the border edge on a spare needle, cont on the remaining **16-17-19-21-23** sts only.

Shoulder:

When work measures **64-66-68-70-72** cm (**25-26-26½-27½-28¼** in) [**100-104-106-110-114** rows] total, leave the remaining **16-17-19-21-23** sts on a spare needle.

SLEEVES:

Using 9.0 mm needles & 2 strands of yarn held together CO **31-32-33-34-35** sts.

Work **6** cm (**2¼** in) [**10** rows] in G.st.

Starting with a knit row continue in St st for **10-8-8-6-6** rows.

Next row (RS - inc): k2, inc 1, k to last 2 sts, inc 1, k2.

Repeat the inc row on every following **10th-8th-8th-6th-6th** row **2-5-2-7-6** more times, then on every following **8th-0-6th-0-4th** row **2-0-4-0-2** times.

Continue on the **41-44-47-50-53** sts obtained.

Top of sleeve:

When work measures **54** cm (**21¼** in) [**72** rows] total, leave the sts on a spare needle.

FINISHING:

Join the shoulders using chain st on the WS of work (see 'Knitting: Stitches/Techniques/Tips').

Collar:

Slip the **14-16-16-17-18** sts on hold for the Left Front onto a 9.0 mm needles, then the **14-16-16-17-18** sts for the Right Front.

With RS facing k**14-16-16-17-18**, pick up & knit **30-29-32-33-34** sts around the neck (=3 along each Front + **24-23-26-27-28** along the Back), k**14-16-16-17-18**.

On the **58-61-64-67-70** sts obtained work:

3 rows G.st,
2 rows St st,
4 rows G.st,
2 rows St st,
3 rows G.st.

Then cast off all the sts knit-wise on the WS of work.

Using back stitch graft the tops of the sleeves into the armholes.

Sew sleeve & side seams.

Following the diagram according to the size you are working, sew on the fasteners using the brown thread.

Secure & weave in all ends.

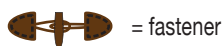

DIAGRAM sizes S - M & L

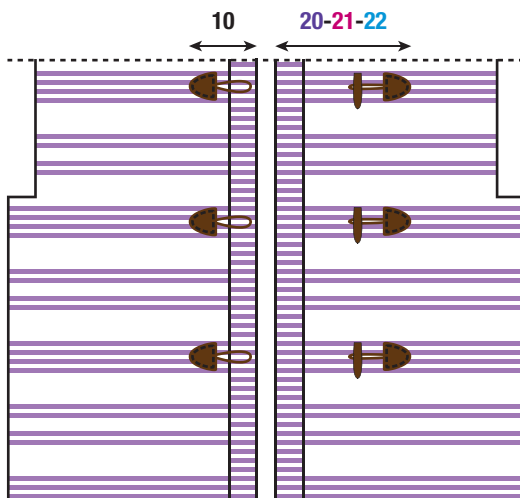
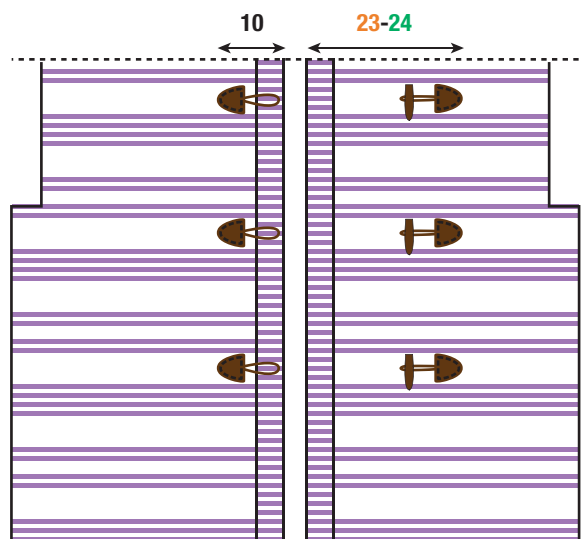

DIAGRAM sizes XL & XXL



JACKET



Quality: **FILÉCO**

Needles: **5.0 mm**



Accessories:
Stitch markers ref. 68395 (pk of 48)
4 ebony buttons 30 mm dia. ref. 55720 (pk of 6)
Sewing thread the same colour as the Ecobleu (not sold)

Sizes		S	M	L	XL	XXL
Quality FILÉCO		Number of balls				
Ecobeige (A)	54634	12	13	14	15	16
Ecobleu (B)	54640	1	1	1	1	1

Stitches used

STOCKING ST (St st), using 5.0 mm needles.

Row 1 (RS): knit.

Row 2: purl.

Rep these 2 rows.

CORN ST, using 5.0 mm needles.

Row 1: *k1, p1* rep from *to* ending with k1.

Row 2: *p1, k1* rep from *to* ending with p1.

Row 3: *p1, k1* rep from *to* ending with p1.

Row 4: *k1, p1* rep from *to* ending with k1.

Rep these 4 rows.

Tension/Gauge

To achieve a good result it is essential to make a tension square (see "Check Your Tension" instructions at beginning of book).

16 sts & 20 rows over St st using 5.0 mm needles = 10 cm (4 in) square.

14.5 sts & 21 rows over Corn st using 5.0 mm needles = 10 cm (4 in) square.

To make

BACK:

Using col A cast on **79-85-91-98-106** sts. Starting with a knit row cont in St st until work measures **49-50-51-51-52** cm (**19¼-19¾-20-20-20½** in) [**98-100-102-102-104** rows] total.

Armholes:

Slip a stitch marker into the first & last stitch of the row to mark the beg of the armholes (see diagram) then cont in St st until work measures **68-70-72-74-76** cm (**26¾-27½-28¼-29-30** in) [**136-140-144-148-152** rows] total.

Shoulders & Neck:

Next row (RS): Cast off **9-9-10-11-12** sts, work **20-22-23-25-27** sts, cast off the central **21-23-25-26-28** sts, work to end.

Next row (WS): Work to cast off sts & put rem sts on a stitch holder. Work will now be completed in 2 sections.

***Next row (neck edge):** Cast off 2 sts, work to end.

Cont to cast off at the shoulder edge on every alt row as foll: **9-10-10-11-12** sts **2-2-1-1-1** times, then **0-0-11-12-13** sts once.*

With WS facing pick up sts left on stitch holder. Work from *to* above.

RIGHT FRONT:

Using col A cast on **47-50-53-57-61** sts. Starting with a knit row cont in St st until work measures **49-50-51-51-52** cm (**19¼-19¾-20-20-20½** in) [**98-100-102-102-104** rows] total.

Armholes:

Slip a stitch marker into the first & last stitch of the row to mark the beg of the armholes (see diagram) then cont in St st until work measures **64-66-68-70-72** cm (**25¼-26-26¾-27½-28¼** in) [**128-132-136-140-144** rows] total.

Neck:

Cast off at the beg of every RS row as foll: **15-16-17-18-19** sts once, 2 sts twice, 1 st once. **27-29-31-34-37** sts rem.

Shoulder:

When work measures **68-70-72-74-76** cm (**26¾-27½-28¼-29-30** in) [**136-140-144-148-152** rows] total cast off at the beg of every WS row as foll: **9-9-10-11-12** sts **3-1-2-2-2** times, then **0-10-11-12-13** sts **0-2-1-1-1** times.

LEFT FRONT:

Using col A cast on **47-50-53-57-61** sts. Starting with a knit row cont in St st until work measures **16-15-17-16-15** cm (**6¼-6-6¾-6¼-6** in) [**32-30-34-32-30** rows] total.

Buttonholes:

Next row (RS): Work until 6 sts rem on LH needle, yon, k2tog (= 1 buttonhole), k4.

Cont in St st until work measures **31-31-33-33-33** cm (**12¼-12¼-13-13-13** in) [**62-62-66-66-66** rows] total, then make another buttonhole as before.

Cont in St st until work measures **46-47-49-50-51** cm (**18-18½-19¼-19½-20** in) [**92-94-98-100-102** rows] total, then make another buttonhole as before. Cont in St st until work measures **49-50-51-51-52** cm (**19¼-19¾-20-20-20½** in) [**98-100-102-102-104** rows] total.

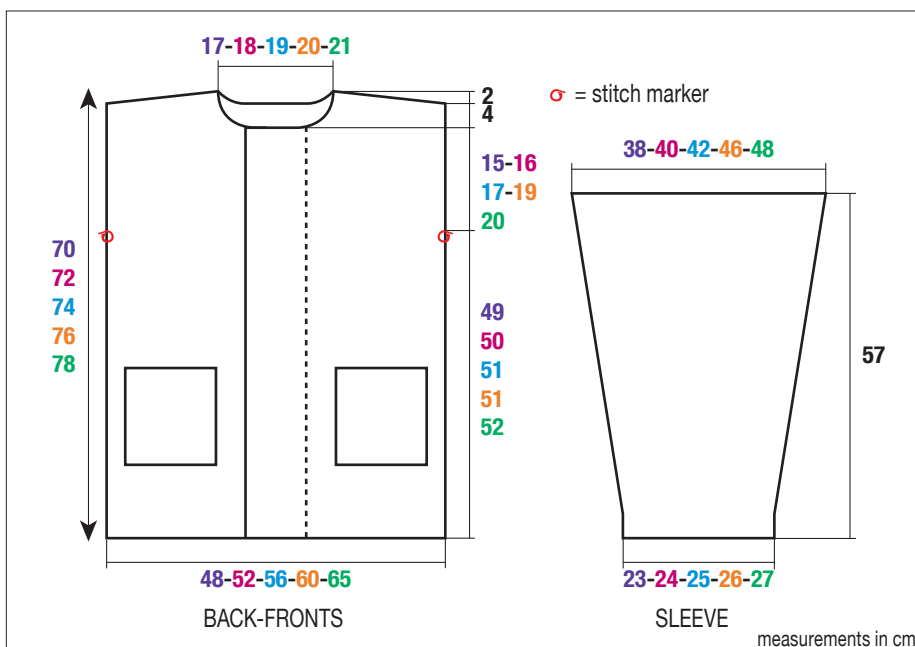

JACKET WITH HIGH COLLAR



Quality: **FILÉCO**
 Needles: **5.0 mm**
 Crochet hook size: **3.5 mm**

Accessories:
4 boxwood toggles 40 mm long ref. 63996 (pk of 6)
2 boxwood buttons 18 mm ref. 65294 (pk of 6)

Sizes		4 yrs	6 yrs	8 yrs	10 yrs
Quality FILÉCO		Number of balls			
Ecorouge	54631	7	8	9	10

Starting with a knit row cont in St st until work measures **26-29-32-35** cm (**10¼-11¼-12½-13¾** in) [**56-62-68-74** rows] total.

Starting with a knit row cont in St st until work measures **26-29-32-35** cm (**10¼-11¼-12½-13¾** in) [**56-62-68-74** rows] total.

● Abbreviations

Slip 1: with yarn at **back** of work, slip 1 purl-wise.

● Stitches used

PATTERN STITCH, using 5.0 mm needles.

Rows 1 (RS) & 2: purl.

Rows 3-4 & 5: knit.

Rows 6-7 & 8: purl.

Rep Rows 3-8.

STOCKING ST (St st), using 5.0 mm needles.

Row 1 (RS): knit.

Row 2: purl.

Rep these 2 rows.

BORDER STITCH, using 5.0 mm needles. Over 15 sts.

Row 1 (RS): k4, p2, k3, p2, k4.

Row 2: p4, k2, p3, k2, p4.

Row 3: sl1, k2, sl1, p2, sl3, p2, sl1, k2, sl1.

Row 4: p1, sl2, p1, k2, p3, k2, p1, sl2, p1.

Rep Rows 3 & 4.

Crochet basics: See 'Crochet: Stitches/Techniques'.

● Tension/Gauge

To achieve a good result it is essential to make a tension square (see "Check Your Tension" instructions at beginning of book).

16 sts & 24.5 rows over Pattern stitch using 5.0 mm needles = 10 cm (4 in) square.

16 sts & 20 rows over St st using 5.0 mm needles = 10 cm (4 in) square.

● To make

BACK:

Using 5.0 mm needles CO **53-58-62-67** sts.

Work **8 cm (3 in) [20 rows]** in Pattern st.

Armholes:

Cast off 2 sts at beginning of next **2-2-2-4** rows.

Next row (RS – dec): k2, k2tog, k until 4 sts rem on LH needle, sl1, k1, pssso, k2.

Rep this dec on every foll RS row **2-3-3-2** more times.

Continue on the remaining **43-46-50-53** sts in St st until work measures **30-34-38-42** cm (**11¾-13¼-15-16½** in) [**64-72-80-88** rows] total, then change to Pattern st.

Shoulders & neck:

When work measures **40-44-48-52** cm (**15¾-17¼-19-20½** in) [**88-96-104-112** rows] total, cast off: 3 sts at beg of next **6-6-4-2** rows, **0-0-4-4** sts at beg of foll **0-0-2-4** rows, then cast off the rem **25-28-30-31** sts (= **3-4-4-4** sts each side for the shoulders & **19-20-22-23** sts for the neck).

LEFT FRONT:

Using 5.0 mm needles CO **23-26-28-30** sts.

Work **8 cm (3 in) [20 rows]** in Pattern st.

Armhole:

Cast off 2 sts at beginning of next **1-1-1-2** RS rows.

Next row (RS – dec): k2, k2tog, k to end.

Rep this dec on every foll RS row **2-3-3-2** more times.

Continue on the remaining **18-20-22-23** sts in St st until work measures **30-34-38-42** cm (**11¾-13¼-15-16½** in) [**64-72-80-88** rows] total, then change to Pattern st.

Neck:

When work measures **37-41-45-49** cm (**14½-16-17¼-19¼** in) [**80-88-96-104** rows] total, cast off at beg of every WS row: **3-3-4-4** sts once, 2 sts once, 1 st **1-2-2-2** times. **12-13-14-15** sts rem.

Shoulder:

When work measures **40-44-48-52** cm (**15¾-17¼-19-20½** in) [**88-96-104-112** rows] total, cast off at beg of every RS row: 3 sts **4-3-2-1** times, **0-4-4-4** sts **0-1-2-3** times.

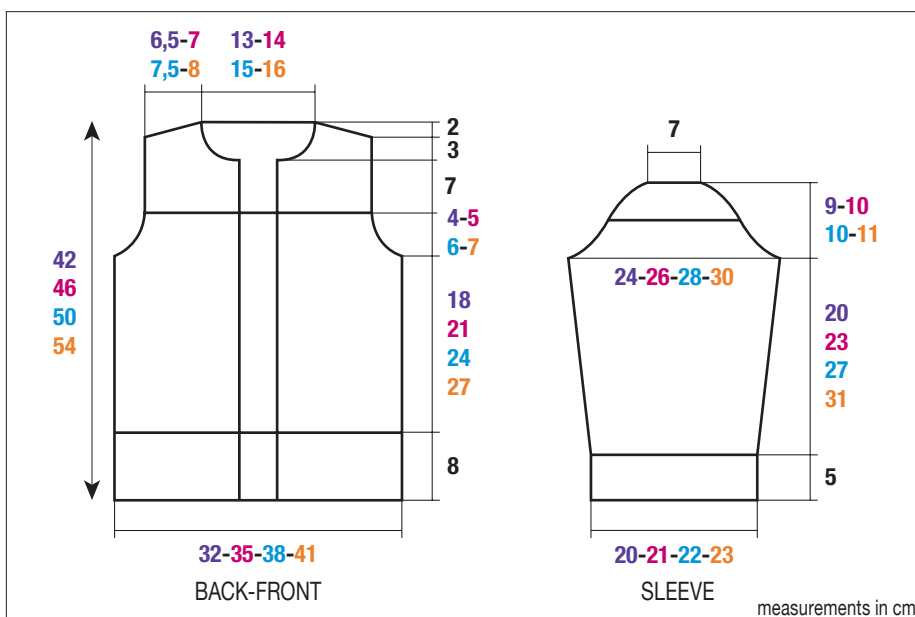

RIGHT FRONT:

Using 5.0 mm needles CO **23-26-28-30** sts.

Work **8 cm (3 in) [20 rows]** in Pattern st.

Starting with a knit row cont in St st until work measures **26-29-32-35 cm (10¼-11¼-12½-13¾ in) [56-62-68-74 rows]** total.

Armhole:

Cast off 2 sts at beginning of next **1-1-1-2** WS rows.

Next row (RS – dec): k until 4 sts rem on LH needle, sl1, k1, pssso, k2.

Rep this dec on every foll WS row **2-3-3-2** more times.

Continue on the remaining **18-20-22-23** sts in St st until work measures **30-34-38-42 cm (11¾-13¼-15-16½ in) [64-72-80-88 rows]** total, then change to Pattern st.

Neck:

When work measures **37-41-45-49 cm (14½-16-17¾-19¼ in) [80-88-96-104 rows]** total, cast off at beg of every RS row: **3-3-4-4** sts once, 2 sts once, 1 st **1-2-2-2** times. **12-13-14-15** sts rem.

Shoulder:

When work measures **40-44-48-52 cm (15¾-17¼-19-20½ in) [88-96-104-112 rows]** total, cast off at beg of every WS row: 3 sts **4-3-2-1** times, **0-4-4-4** sts **0-1-2-3** times.

SLEEVES:

Using 5.0 mm needles CO **34-35-37-38** sts.

Work **5 cm (2 in) [14 rows]** in Pattern st.

Starting with a knit row cont in St st for 10 rows.

Next row (RS – inc): k2, inc 1, k to last 2 sts, inc 1, k2.

Rep this inc on every foll 10th row **2-1-1-1** more times, then on every foll **0-8th-8th-8th** row **0-2-3-4** times.

Cont on the **40-43-47-50** sts obtained until work measures **25-28-32-36 cm (9¾-11-12½-14¼ in) [54-60-68-76 rows]** total.

Top of sleeve:

Cast off: **2-2-3-3** sts at beg of next 2 rows, **0-0-2-2** sts at beg of foll **0-0-2-2** rows.

Next row (RS – dec): k2, k2tog, k until 4 sts rem on LH needle, sl 1, k1, pssso, k2.

Rep this dec row every foll RS row **1-2-1-2** times.

After the final dec, work 1 row on the rem **32-33-33-34** sts.

Cont in Pattern st as foll: dec 1 st at each end of every RS row **5-5-5-4** times, work 1 row straight then cast off: 2 sts at beg of next **2-2-2-4** rows, 3 sts at beg of foll 2 rows. Cast off rem **12-13-13-12** sts.

FRONT BORDERS (2):

Using 5.0 mm needles CO 15 sts. Cont in Border patt until work measures **37-41-45-49 cm (14½-16-17¾-19¼ in)**, cast off all the sts.

COLLAR:

Using 5.0 mm needles CO **62-65-68-71** sts. Cont in Pattern st for 4 rows.

Next row (RS): patt until there are 5 sts rem on the LH needle, yo, k2tog (= 1 buttonhole), k3.

Rep this buttonhole row on the **15th-15th-17th-17th** row.

When work measures **11-11-13-13 cm (4¼-4¼-5-5 in) [26-26-32-32 rows]** total, leave the sts on a spare needle.

FINISHING:

Sew a border along each Front edge.

Join the shoulder seams.

On the WS of work and using back stitch graft the collar around the neck from one border to the other. (See: Knitting: Stitches/Techniques/Tips).

Sew the tops of the sleeves into the armholes.

Sew sleeve & side seams.

Fold the collar RS out, then sew on 2 buttons 4 sts in from the edge & opposite the buttonholes.

Fasteners (4):

Loop section:

With the 3.5 mm crochet hook make a chain of **16** sts and fasten off.

Fastening chain:

Slip 2 strands of yarn through the holes on the toggle, then with the 4 strands (2 x 2 strands) & the 3.5 mm crochet hook, make a chain of **4** sts and fasten off.

Sew on the fasteners (see placement on the diagram).

Secure & weave in all ends.

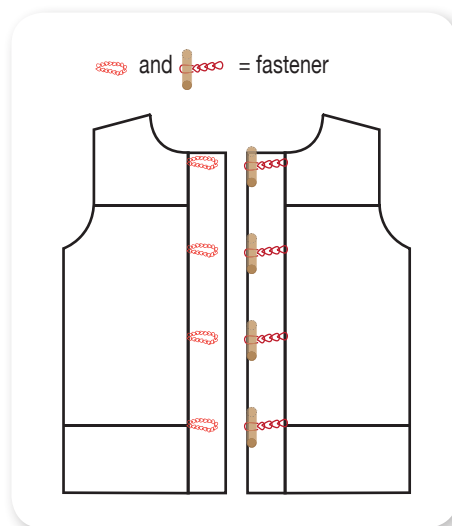

PONCHO



Quality: **FILÉCO**

Needles: **6.5 mm**

Accessories:
8 heart buttons ref. 30731 (pk of 6)

Sizes	3 mths	6 mths	12 mths	18 mths	24 mths
Quality FILÉCO	Number of balls				
Ecobrique 54628	3	3	3	4	4

Stitches used

GARTER ST (G.st), using 6.5 mm needles.
Knit every row.

Tension/Gauge

To achieve a good result it is essential to make a tension square (see “Check Your Tension” instructions at beginning of book).

13 sts & 24 rows over G.st using 6.5 mm needles = 10 cm (4 in) square.

To make

The poncho is made in one section started at the front.

Cast on **37-40-42-44-46** sts & cont in G.st until work measures **22-25-28-30-32** cm (**8½-9¾-11-11¾-12½** in) [**54-60-68-72-78** rows] total.

Front Neck:

Next row (RS): Work **12-13-14-14-15** sts, cast off the central **13-14-14-16-16** sts, work to end.

Next row (WS): Work **12-13-14-14-15** sts, leave rem sts on a stitch holder. Work will now be completed in 2 sections.

Cont in G.st until work measures **28-31-34-36-38** cm (**11-12¼-13¼-14-15** in) [**68-74-82-86-92** rows] total, then leave on a stitch holder.

With WS facing pick up sts left on 1st stitch holder. Cont in G.st until work measures **28-31-34-36-38** cm (**11-12¼-13¼-14-15** in) [**68-74-82-86-92** rows] total.

Back Neck:

Next row (RS): Work across the **12-13-14-14-15** sts on needle, place the **12-13-14-14-15** sts from the second stitch holder onto the LH needle ready to knit a RS row, cast on **13-14-14-16-16** new sts between the 2 sets of sts & knit to the end of the row. Cont in G.st on the **37-40-42-44-46** sts obtained.

When work measures **50-56-62-66-70** cm (**19¾-22-24½-26-27½** in) [**123-135-151-159-171** rows] total cast off all sts knitwise on the WS of work.

FINISHING:

Sew 4 buttons to each edge of the Front (see diagram for position) through both layers: the 1st 1 cm (½ in) from the bottom, the 2nd **11-13-15-16-17** cm (**4¼-5-6-6¼-6¾** in) from the cast on edge, the other 2 at regular spacings between.

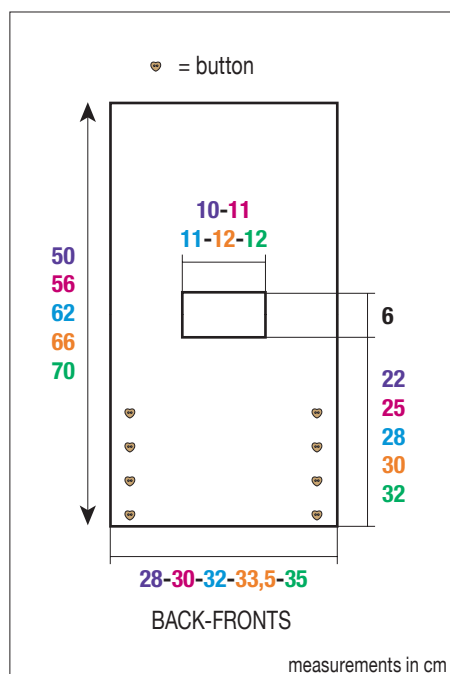

V NECK SWEATER



Quality: **FILECO**

Needles: **4.5 & 5.0 mm**

Accessories: **Stitch markers ref. 68395 (pk of 48)**

Sizes		S	M	L	XL	XXL
Quality FILECO		Number of balls				
Ecomarine	54642	9	10	11	12	13

Stitches used

1/1 RIB, using 4.5 mm needles.

Row 1 (RS): *k1, p1* rep from *to* ending with k1.

Row 2: *p1, k1* rep from *to* ending with p1.

Rep these 2 rows.

STOCKING ST (St st), using 5.0 mm needles.

Row 1 (RS): knit.

Row 2: purl.

Rep these 2 rows.

Tension/Gauge

To achieve a good result it is essential to make a tension square (see "Check Your Tension" instructions at beginning of book).

16 sts & 20 rows over St st using 5.0 mm needles = 10 cm (4 in) square.

To make

BACK:

Using 4.5 mm needles cast on **93-101-107-117-125** sts.

Row 1 (RS): *k1, p1* rep from *to* ending with k1.

Row 2: *p1, k1* rep from *to* ending with p1.

These 2 rows form 1/1 rib, cont as est until work measures **6 cm (2¼ in)** [14 rows] total, **but** on the final row, make **7-9-9-11-11** decreases evenly across row.

Change to 5.0 mm needles & starting with a knit row cont in St st on the rem **86-92-98-106-114** sts until work measures **40-41-41-42-43 cm (15¼-16-16-16½-17 in)** [82-84-84-86-88 rows] total.

Armholes:

Slip a stitch marker into the beg & end of the next row to mark the beginning of the armholes (see diagram), then continue in St st until work measures **58-60-62-64-66 cm (22¾-23½-24½-25-26 in)** [118-122-126-130-134 rows] total.

Shoulders & Neck:

Next row (RS): Cast off **9-10-11-12-13** sts, work **22-23-24-26-28** sts, cast off the central **24-26-28-30-32** sts, work to end.

Next row (WS): Cast off **9-10-11-12-13** sts, work to cast off sts & put rem sts on a stitch holder. Work will now be completed in 2 sections.

***Next row (neck edge):** Cast off 2 sts, work to end.

Cont to cast off at the shoulder edge on every alt row as foll: **10-10-11-12-13** sts **2-1-2-2-2** times, then **0-11-0-0-0** sts **0-1-0-0-0** times.*

With WS facing pick up sts from stitch holder & work from *to* above.

FRONT:

Work as for Back until after armhole marking & work measures **36-37-37-38-39 cm (14-14½-14½-15-15¼ in)** [74-76-76-78-80 rows] total.

Neck:

Next row (RS): Work **43-46-49-53-57** sts, put the rem **43-46-49-53-57** sts on a stitch holder. Work will now be completed in 2 sections.

Work 1 row straight.

Next row (RS-dec): Work until 7 sts rem on LH needle, sl 1, k1, pss0, k5.

Rep this dec on every RS row **13-14-15-16-17** more times.

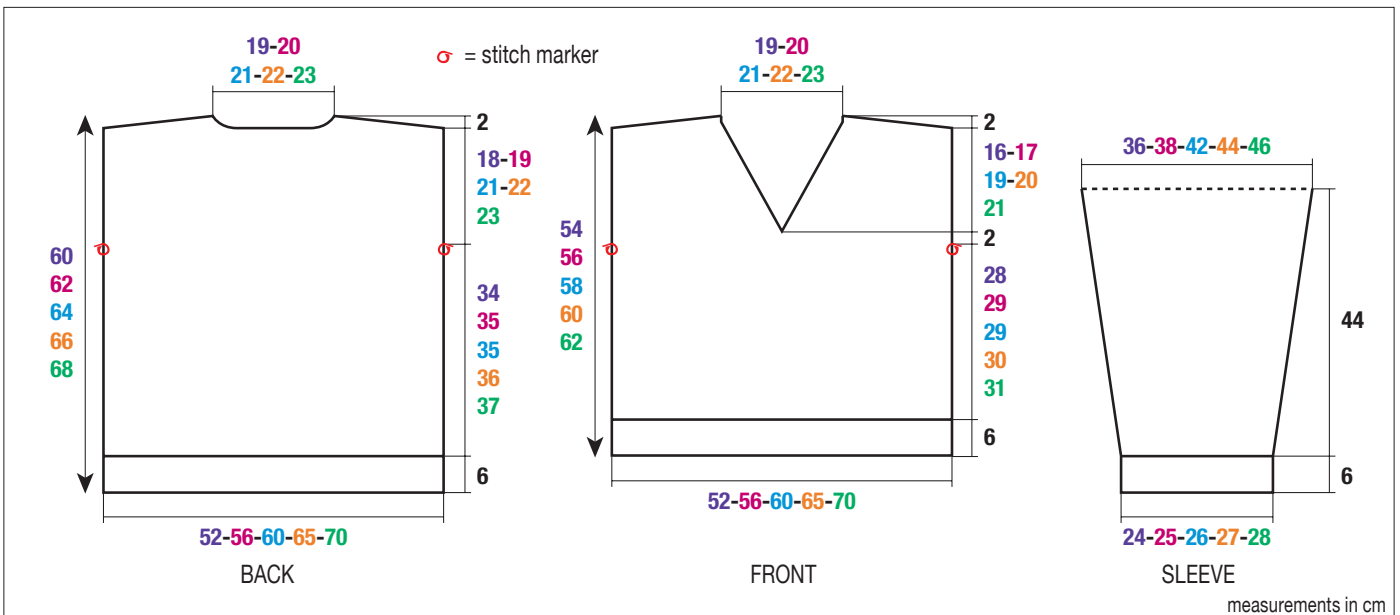

Cont on the rem **29-31-33-36-39** sts until work measures **52-54-56-58-60** cm (**20½-21¼-22-22¾-23½** in) [**106-110-114-118-122** rows] total.

Shoulder:

Cast off at the beg of every RS row as foll: **9-10-11-12-13** sts **1-2-3-3-3** times, then **10-11-0-0-0** sts **2-1-0-0-0** times.

With RS facing pick up sts left on stitch holder.

Next row (RS-dec): k5, k2tog, work to end.

Rep this dec on every RS row **13-14-15-16-17** more times.

Cont on the rem **29-31-33-36-39** sts until work measures **52-54-56-58-60** cm (**20½-21¼-22-22¾-23½** in) [**106-110-114-118-122** rows] total.

Shoulder:

Cast off at the beg of every WS row as foll: **9-10-11-12-13** sts **1-2-3-3-3** times, then **10-11-0-0-0** sts **2-1-0-0-0** times.

SLEEVES:

Using 4.5 mm needles cast on **39-41-43-43-45** sts.

Work in 1/1 rib as for Back until work measures **6** cm (**2¼** in) [**14** rows] total, **but** on the final row **for size XL only** inc 1 st.

Change to 5.0 mm needles & starting with a knit row cont in St st on the **39-41-43-44-45** sts obtained for **8-8-6-6-6** rows.

Next row (RS – inc): k2, inc 1, work to last 2 sts, inc 1, k2.

Rep this inc on every foll **8th-8th-6th-6th-6th** row **9-6-12-11-10** times, then on every foll **0-6th-0-4th-4th** row **0-4-0-2-4** times.

Cont on the **59-63-69-72-75** sts obtained until work measures **50** cm (**19½** in) [**102** rows] total.

Top of sleeve:

Leave all sts on a spare needle.

FINISHING:

Join the shoulder seams.

Using back stitch graft the top of the sleeves to the armhole edge (See 'Knitting: Stitches/Techniques/Tips') between the stitch markers.

Sew the sleeve & side seams leaving the bottom **6** cm (**2¼** in) of the Back open.

Secure & weave in all ends.



CABLE SWEATER WITH HIGH COLLAR



Quality: **FILÉCO**

Needles: **4.5 & 5.0 mm Cable Needle**

Sizes		S	M	L	XL	XXL
Quality FILÉCO		Number of balls				
Ecomauve	54623	12	13	15	16	17

● To make

BACK :

Using 4.5 mm needles CO **79-85-91-99-107** sts.

Row 1 (RS): *k1, p1, rep from * to last st, k1.

Row 2: *p1, k1, rep from * to last st, p1.

These 2 rows form 1/1 rib, rep until work measures **5 cm (2 in) [12 rows]**.

Change to 5.0 mm needles and foll the Chart according to the size you are working, making **14** incs on the 1st row (see placement on the Chart) (= **93-99-105-113-121** sts).

Raglan:

When work measures **37-38-38-39-40** cm (**14½-15-15-15¼-15½** in) [**76-78-78-80-82** rows] total cast off **5-4-5-5-6** sts at beg of next 2 rows. **83-91-95-103-109** sts rem.

Size S:

Next row (RS – 2 st dec): k3, k3tog, patt until there are 6 sts rem on the LH needle, sl1, k2tog, pssso, k3. Work 1 row straight.

Next row (RS – 1 st dec): k3, k2tog, patt until there are 5 sts rem on the LH needle, sl1, k1, pssso, k3.

Rep the 1 st dec row on every RS row 20 more times.

Sizes: M-L-XL & XXL:

* **Next row (RS – 1 st dec):** k3, k2tog, patt until there are 5 sts rem on the LH needle, sl1, k1, pssso, k3. Work 1 row straight.

Next row (RS – 2 st dec): k3, k3tog, patt until there are 6 sts rem on the LH needle, sl1, k2tog, pssso, k3. Work 1 row straight.*

Rep from * to * **2-2-4-5** more times, then rep the 1 st dec row on every RS row **17-19-16-15** more times.

After the final raglan dec, work **1** row on the rem **37-39-39-41-43** sts and cast off all the sts for the neck.

FRONT:

Start the same as for Back up to raglan shaping. **93-99-105-113-121** sts.

Raglan & neck:

When work measures **37-38-38-39-40** cm (**14½-15-15-15¼-15½** in) [**76-78-78-80-82** rows] total cast off **5-4-5-5-6** sts at beg of next 2 rows. **83-91-95-103-109** sts rem.

● Abbreviations

Cross Left = CL

Cross Right = CR

4CL: Slip 2 sts onto a cn at front of work, k2, then k2 from cn.

4CR: Slip 2 sts onto a cn at back of work, k2, then k2 from cn.

1CLK2: Slip 1 st onto a cn at front of work, k2, then k1 from cn.

1CRK2: Slip 2 sts onto a cn at back of work, k1, then k2 from cn.

● Stitches used

1/1 RIB, using 4.5 mm needles.

STOCKING STITCH (St st) & REVERSE STOCKING ST (Rev St st), using 5.0 mm needles.

CABLE PATTERN A, using 5.0 mm needles. Over 16 sts. Follow the Chart.

CABLE PATTERN B, using 5.0 mm needles. Over 16 sts. Follow the Chart.

CABLE PATTERN C, using 5.0 mm needles. Over 17 sts. Follow the Chart.

CABLE PATTERN D, using 5.0 mm needles. Over 17 sts. Follow the Chart.

● Tension/Gauge

To achieve a good result it is essential to make a tension square (see "Check Your Tension" instructions at beginning of book).

16 sts & 20 rows over St st using 5.0 mm needles = 10 cm (4 in) square.

16 sts over Cable Pattern A or B using 5.0 mm needles = 8 cm (3 in) wide.

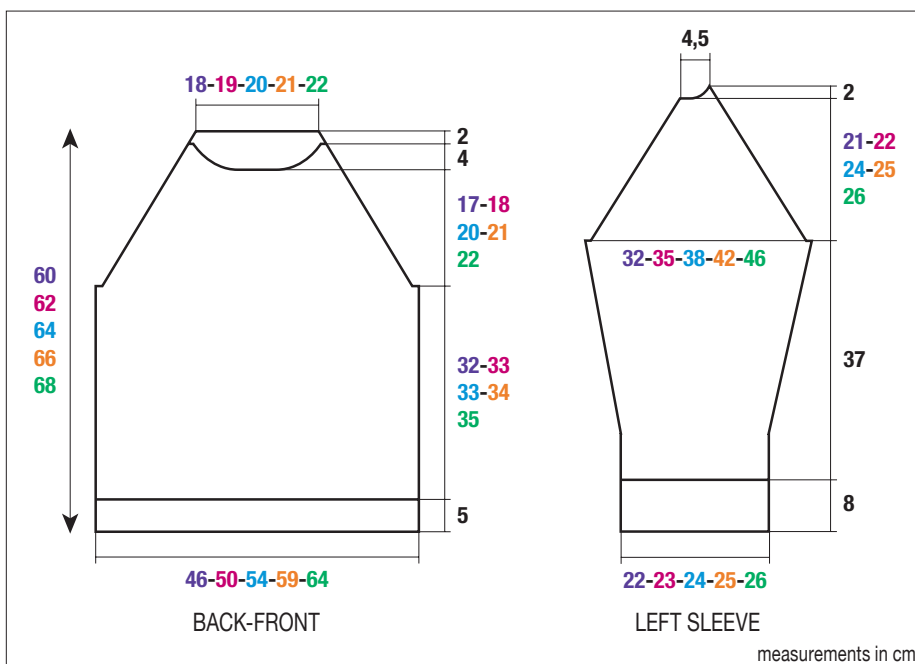

Size S:

Next row (RS – 2 st dec): k3, k3tog, patt until there are 6 sts rem on the LH needle, sl1, k2tog, pssso, k3. Work 1 row straight.

Next row (RS – 1 st dec): k3, k2tog, patt until there are 5 sts rem on the LH needle, sl1, k1, pssso, k3.

Rep the 1 st dec row on every RS row 18 more times.

Sizes: M-L-XL & XXL:

* **Next row (RS – 1 st dec):** k3, k2tog, patt until there are 5 sts rem on the LH needle, sl1, k1, pssso, k3. Work 1 row straight.

Next row (RS – 2 st dec): k3, k3tog, patt until there are 6 sts rem on the LH needle, sl1, k2tog, pssso, k3. Work 1 row straight.*

Rep from * to * 2-2-4-5 more times, then rep the 1 st dec row on every RS row 15-17-14-13 more times.

At the same time, when work measures 54-56-58-60-62 cm (21¼-22-22¾-23½-24¼ in) [110-114-118-122-126 rows] total, cast off the central 21-23-23-25-27 sts for the neck then cont to work each side separately casting off at the neck edge on every alt row: 3 sts once, 2 sts once, 1 st once & the rem 4 sts.

LEFT SLEEVE:

Using 4.5 mm needles CO 37-39-41-43-45 sts.

Work in 1/1 rib as for Back until work measures 8 cm (3 in) [20 rows].

Change to 5.0 mm needles & cont as foll:

Next row (RS): 11-12-13-14-15 st St st, 2 sts Rev St st, 16 st Cable Patt A making 5 incs on the 1st row, 2 sts Rev St st, 11-12-13-14-15 sts St st. 42-44-46-48-50 sts obtained.

Cont in patt as est until work measures 15 cm (6 in) [34 rows] total.

Next row (RS – inc): k2, inc 1, patt to last 2 sts, inc 1, k2.

Rep this inc on every foll 8th-6th-6th-6th-4th row 5-9-5-1-12 more times, then on every foll 6th-0-4th-4th-2nd row 2-0-6-12-3 times.

Cont on the 58-64-70-76-82 sts obtained until work measures 45 cm (17½ in) [94 rows] total

Raglan:

Cast off 4-4-5-5-6 sts at beg of next 2 rows. 50-56-60-66-70 sts rem.

Size S:

Next row (RS – 2 st dec): k3, k3tog, patt until there are 6 sts rem on the LH needle, sl1, k2tog, pssso, k3. Work 1 row straight.

Next row (RS – 1 st dec): k3, k2tog, patt until there are 5 sts rem on the LH needle, sl1, k1, pssso, k3.

Rep the 1 st dec row on every RS row 18 more times.

Sizes M-L-XL & XXL:

* **Next row (RS – 1 st dec):** k3, k2tog, patt until there are 5 sts rem on the LH needle, sl1, k1, pssso, k3. Work 1 row straight.

Next row (RS – 2 st dec): k3, k3tog, patt until there are 6 sts rem on the LH needle, sl1, k2tog, pssso, k3. Work 1 row straight.*

Rep from * to * 2-2-4-5 more times, then rep the 1 st dec row on every RS row 15-17-14-13 more times. Work 1 row straight.

All sizes:

Next row (RS): k3, k2tog, patt to end.

Next row: Cast off 2 sts, patt to end.

Next row: k1, k2tog, patt to end.

Next row: Cast off 1 st, patt to end. Work 1 row straight.

Cast off rem 3 sts.

RIGHT SLEEVE:

Start the same as for Left Sleeve, but replace Cable patt A with Cable patt B.

Work the raglan shaping until 8 sts rem.

All sizes:

Next row (RS): Cast off 2 sts, patt until there are 5 sts rem on LH needle, sl1, k1, pssso, k3. Work 1 row straight.

Next row: Cast off 1 st, patt until there are 3 sts rem on LH needle, sl1, k1, pssso, k1. Work 1 row straight.

Cast off rem 3 sts.

COLLAR:

Using 4.5 mm needles CO 79-81-85-87-91 sts. Work 16 rows in 1/1 rib & leave the sts on a spare needle.

FINISHING:

Join the raglan seams.

Using back stitch graft the collar around the neck and join the short seams. (See: Knitting: Stitches/Techniques/Tips).

Sew sleeve & side seams.

Secure & weave in all ends.

CABLE PATTERN A

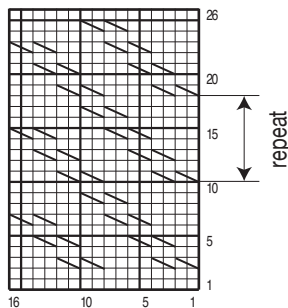

□ = K1 on RS, P1 on WS
▨ = 4CL

CABLE PATTERN B

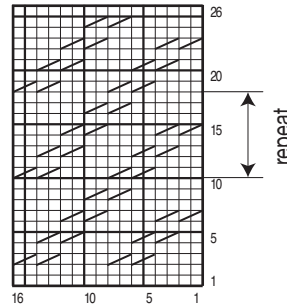

□ = K1 on RS, P1 on WS
▨ = 4CR

BACK-FRONT - Size S

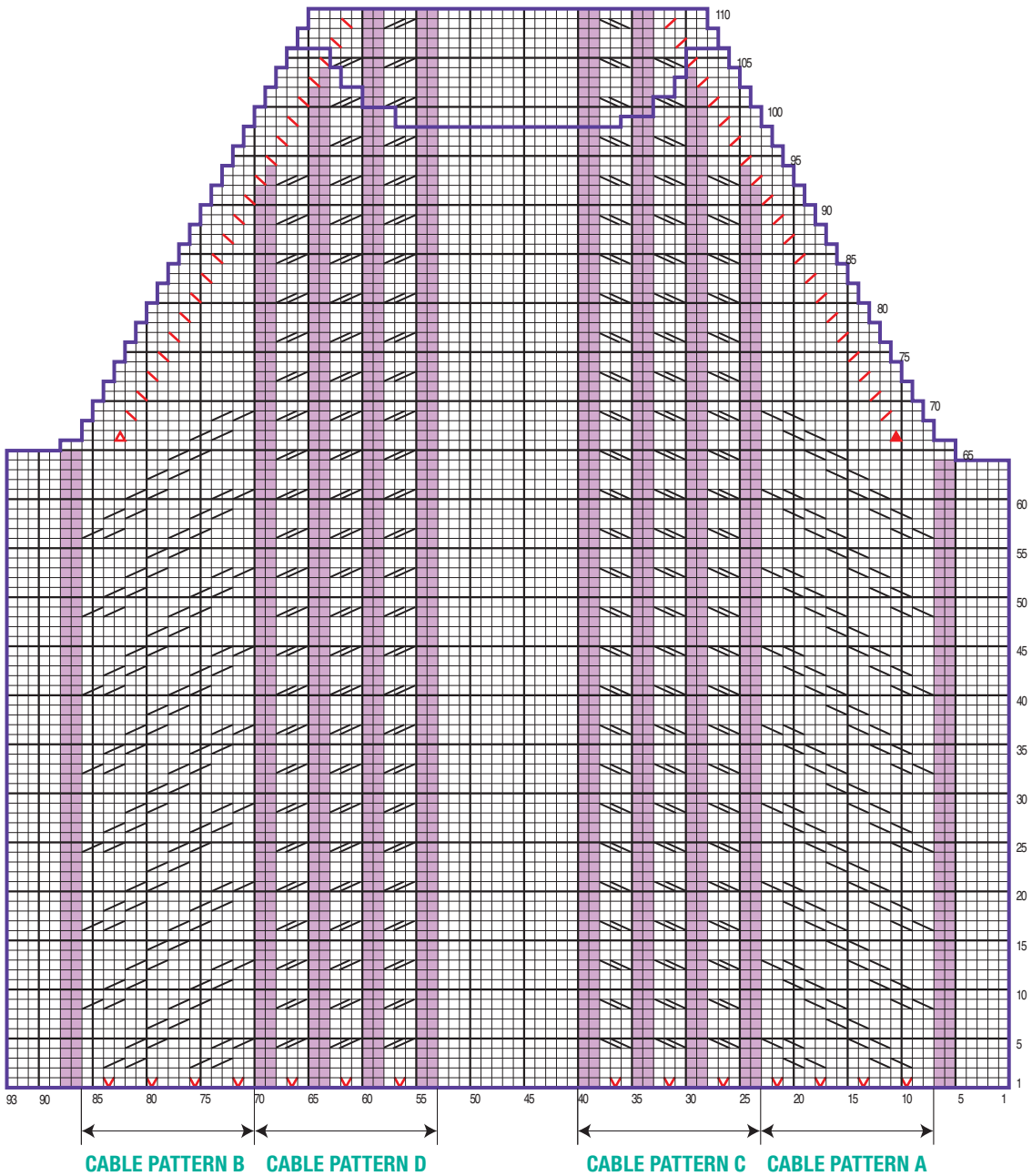

□ = K1 on RS, P1 on WS	▨ = 4CL
■ = P1 on RS, K1 on WS	▩ = 4CR
✓ = inc 1	▧ = CLK2
▲ = k3tog	▦ = CRK2
◻ = sl1, k2tog, pssso	
◻ = k2tog	
◻ = sl1, k1, pssso	

BACK-FRONT - Size M

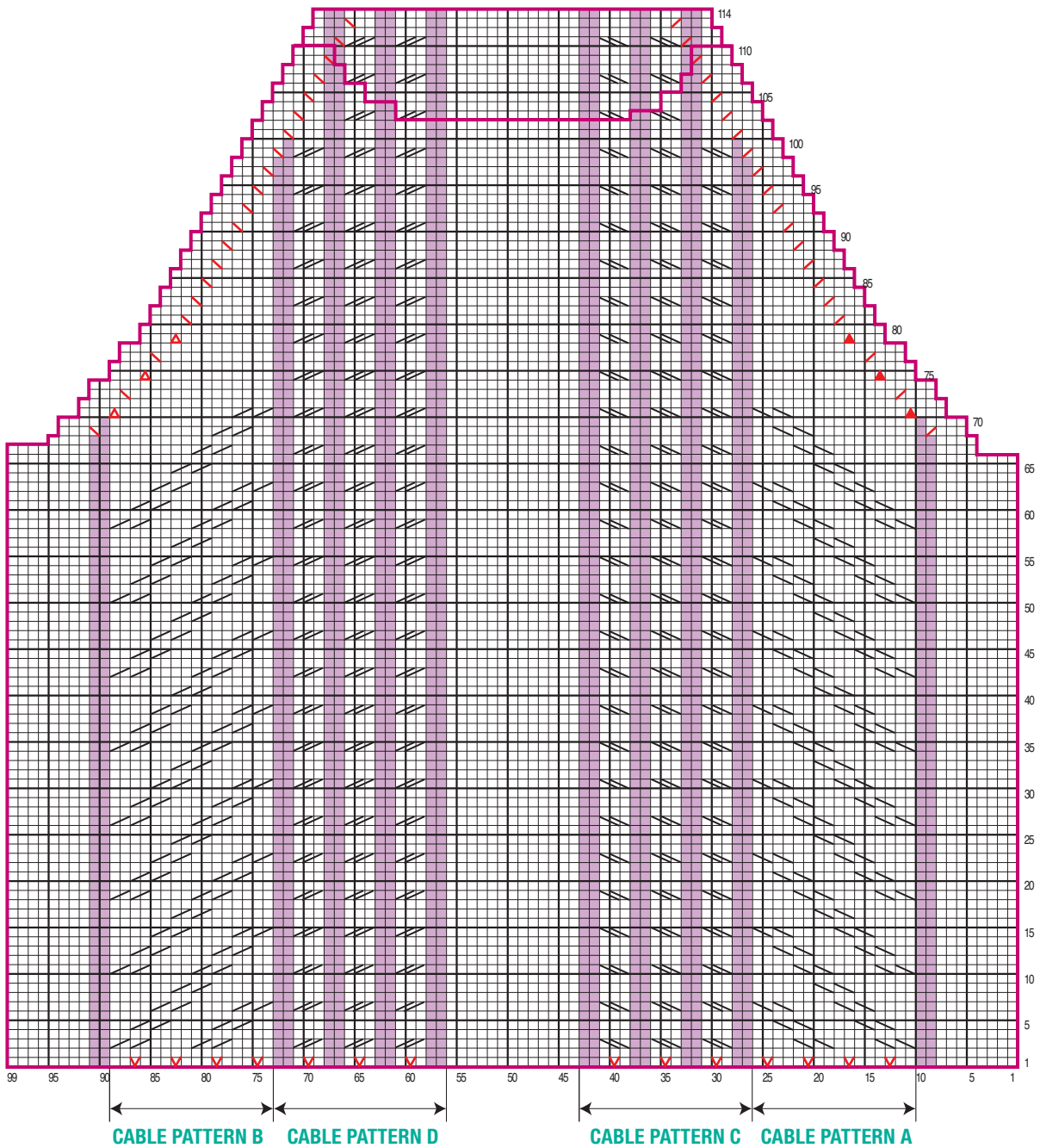

□ = K1 on RS, P1 on WS	▨ = 4CL
■ = P1 on RS, K1 on WS	▩ = 4CR
▣ = inc 1	▧ = CLK2
▤ = k2tog	▦ = CRK2
▥ = sl1, k1, pss0	
▧ = k3tog	
▨ = sl1, k2tog, pss0	

BACK-FRONT - Size L

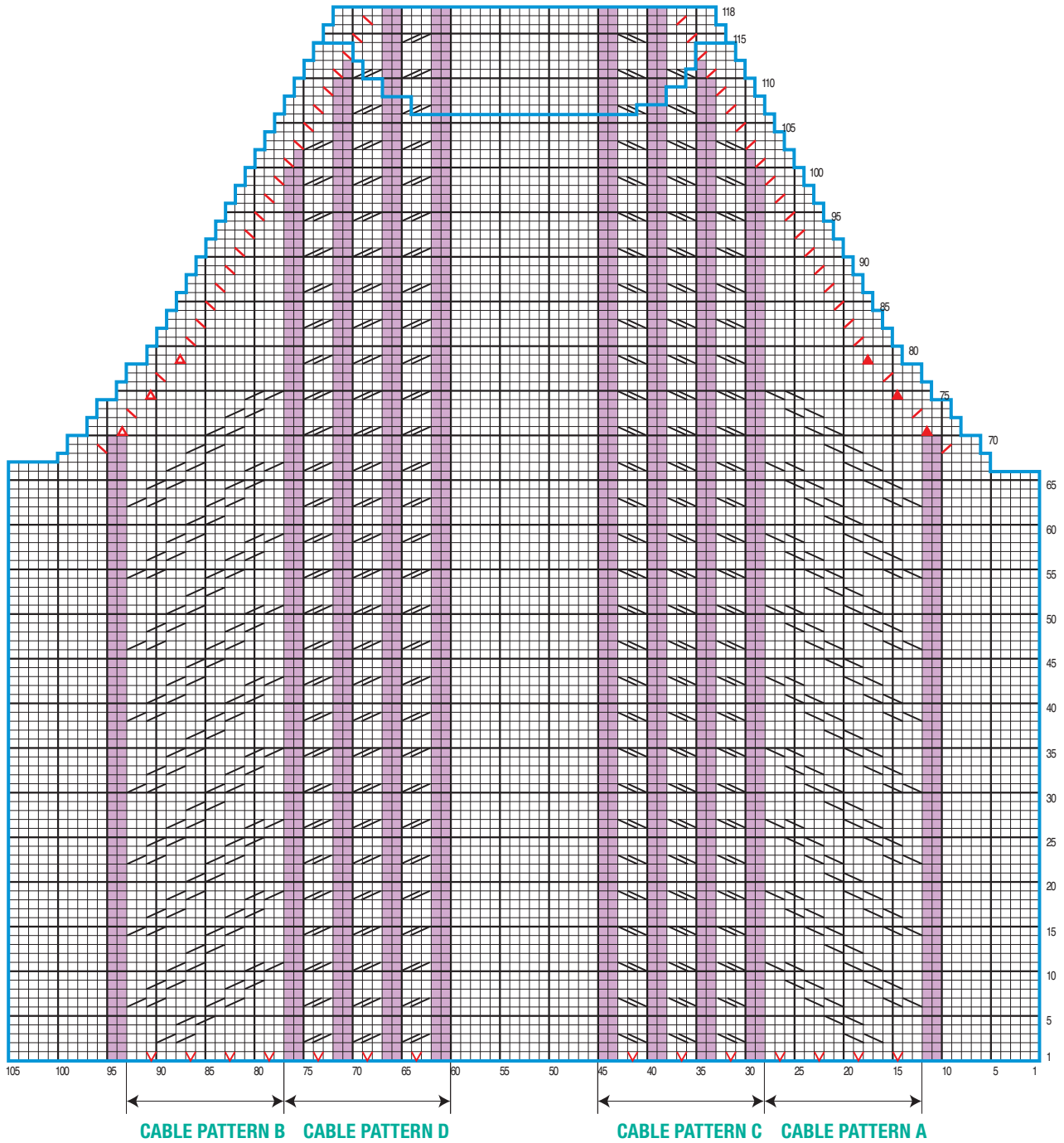

- | | |
|------------------------|----------|
| □ = K1 on RS, P1 on WS | ▨ = 4CL |
| ■ = P1 on RS, K1 on WS | ▩ = 4CR |
| ☑ = inc 1 | ▧ = CLK2 |
| ☒ = k2tog | ▦ = CRK2 |
| ☐ = sl1, k1, pss0 | |
| ▴ = k3tog | |
| ☒ = sl1, k2tog, pss0 | |

BACK-FRONT - Size XL

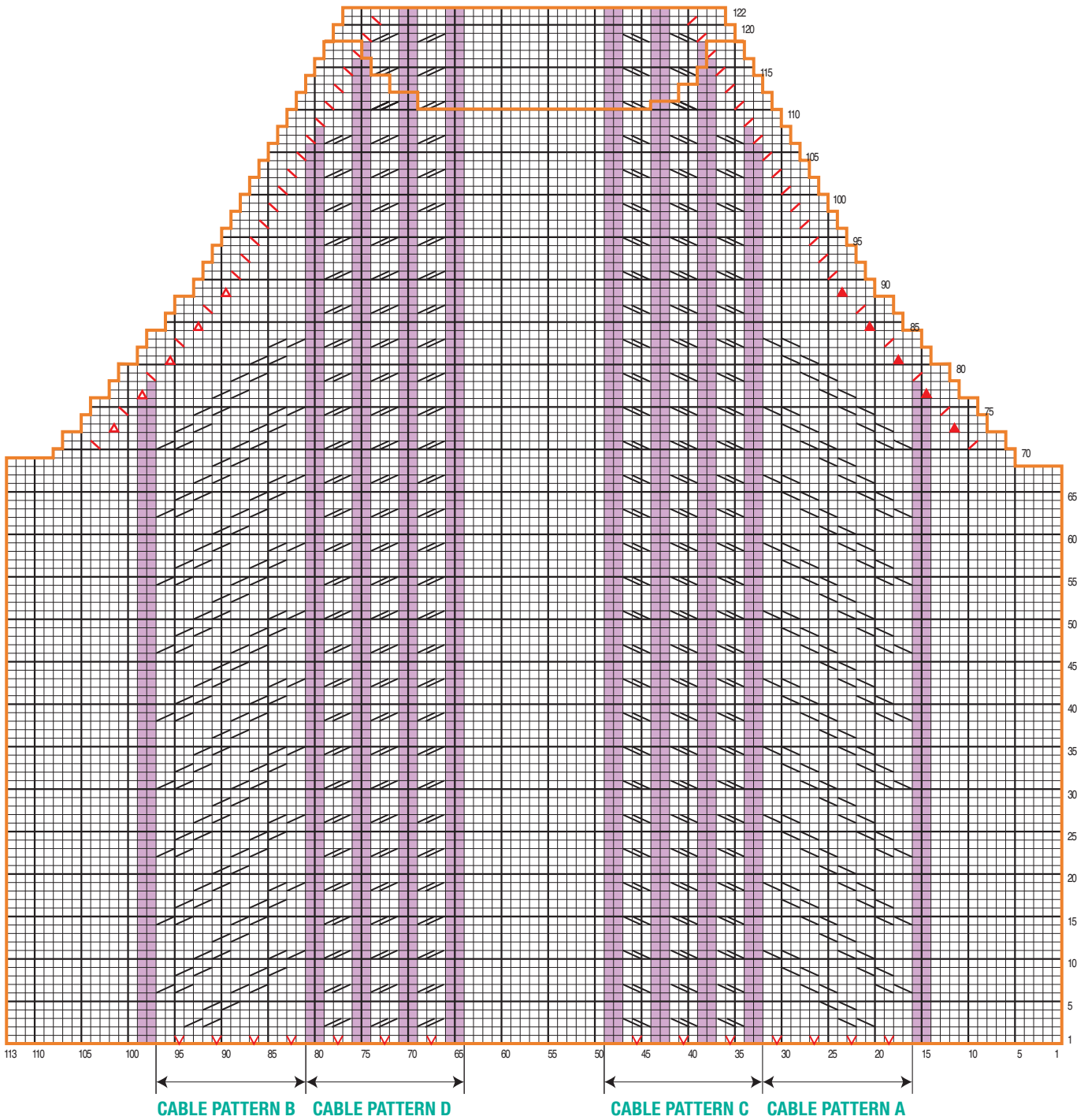

□ = K1 on RS, P1 on WS	▨ = 4CL
■ = P1 on RS, K1 on WS	▩ = 4CR
☑ = inc 1	▧ = CLK2
☒ = k2tog	▦ = CRK2
☐ = sl1, k1, pss0	
☒ = k3tog	
☒ = sl1, k2tog, pss0	

BACK-FRONT - Size XXL

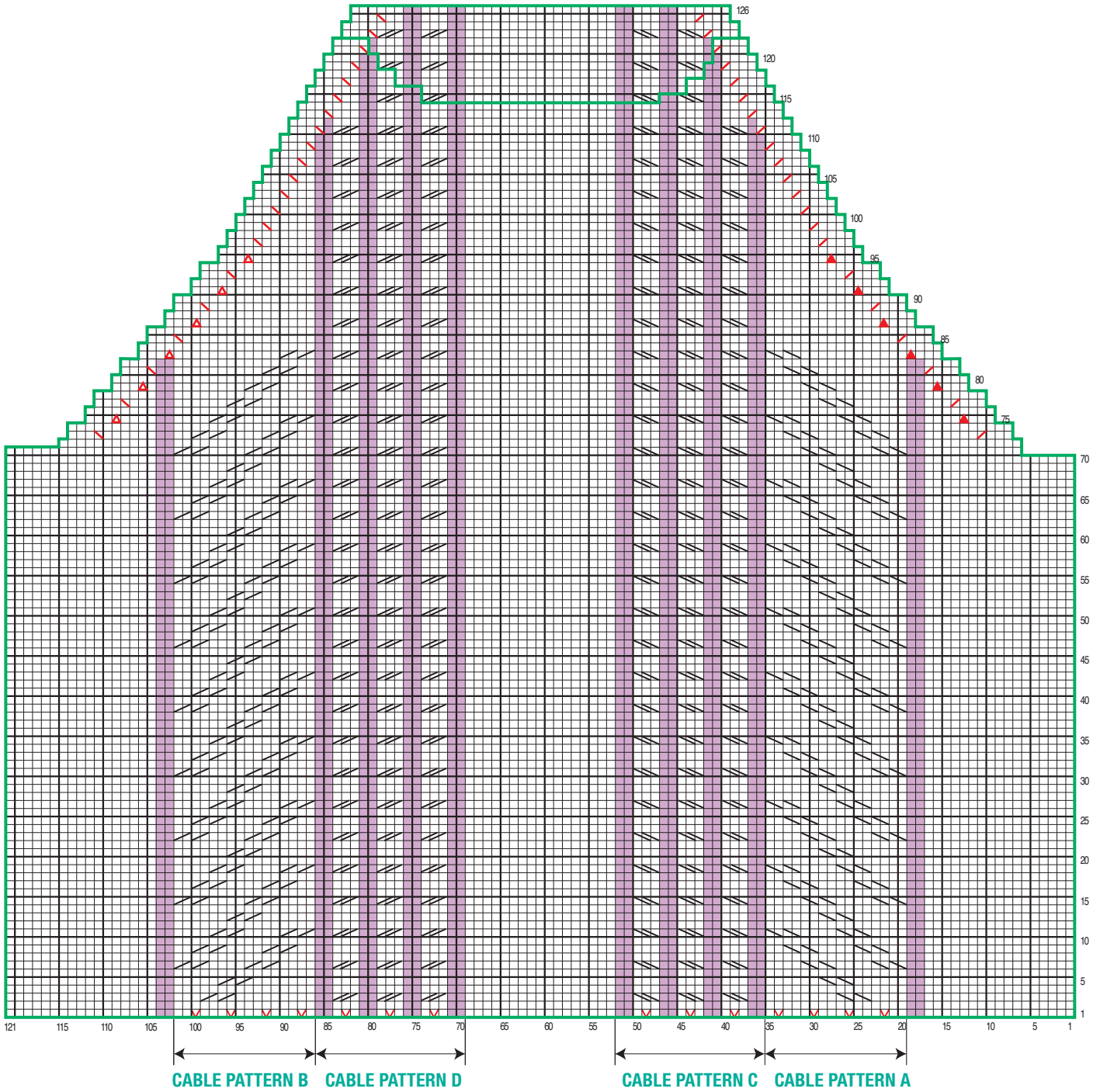

- | | |
|------------------------|----------|
| □ = K1 on RS, P1 on WS | ▨ = 4CL |
| ■ = P1 on RS, K1 on WS | ▩ = 4CR |
| ⊠ = inc 1 | ▧ = CLK2 |
| ⊡ = k2tog | ▦ = CRK2 |
| ⊣ = sl1, k1, pss0 | |
| ⊤ = k3tog | |
| ⊥ = sl1, k2tog, pss0 | |

SLEEPING BAG



Quality:
FILÉCO

Needles:
5.0 mm

Accessories:
8 coconut buttons 15 mm ref. 67715 (pk of 6)

0/6 months

Quality **FILÉCO**

Number of balls

Ecomarine

54642

5

Stitches used

STOCKING ST (St st), using 5.0 mm needles.

Row 1 (RS): Knit.

Row 2: Purl.

Rep these 2 rows.

GARTER STITCH (G.st), using 5.0 mm needles.

Every row knit.

Tension/Gauge

To achieve a good result it is essential to make a tension square (see "Check Your Tension" instructions at beginning of book).

16 sts & 20 rows over St st using 5.0 mm needles = 10 cm (4 in) square.

To make

BACK:

Using 5.0 mm needles CO **62** sts.

Starting with a knit row continue in St st.

When work measures **23 cm (9 in) [46 rows]** total, continue as follows:

Next row (RS): knit.

Next row: k5, p52, k5.

These 2 rows set the pattern for G.st edging and the remainder worked in St st. Continue as established until work measures **44 cm (17¼ in) [88 rows]** total, then continue in G.st across all the sts.

Armholes:

When work measures **47 cm (18½ in) [95 rows]** total, cast off **15** sts at the beginning of the next 2 rows.

Continue in G.st on the remaining **32** sts until work measures **58 cm (22¾ in) [124 rows]** total.

Neck & shoulder tabs:

Next row (RS): k7, cast off the central 18 sts for the neck, k7.

Next row (WS): k7. Put remaining sts on a stitch holder, work will now be completed in 2 sections.

***Next row (RS):** k3, yo, k2tog, (= 1 buttonhole), k2.

Work **3** more rows on the remaining **7** sts and cast off*.

With WS facing pick up sts left on stitch holder & knit 1 row, then repeat from *to* above.

FRONT:

Using 5.0 mm needles CO **62** sts.

Starting with a knit row continue in St st.

When work measures **23 cm (9 in) [46 rows]** total, continue as follows:

Next row (RS): knit.

Next row: k5, p52, k5.

These 2 rows set the pattern for G.st edgings and the remainder worked in St st. Continue as established until work measures **26 cm (10¼ in) [52 rows]** total.

Buttonholes:

Next row (RS): k1, k2tog, yo (= 1 buttonhole), knit to end of row until 3 sts remain on the LH needle, yo, k2tog (= 1 buttonhole), k1.

When work measures **36 cm (14 in) [72 rows]** total, make 2 buttonholes in the same way as before.

When work measures **44 cm (17¼ in) [88 rows]** total, continue in G.st across all the sts.

When work measures **46 cm (18 in) [92 rows]** total, make 2 buttonholes in the same way as before.

Armholes:

When work measures **47 cm (18½ in) [95 rows]** total, cast off 15 sts at the beginning of the next 2 rows.

Continue in G.st on the remaining **32** sts until work measures **54 cm (21¼ in) [114 rows]** total.

Neck & shoulder tabs:

Next row (RS): k7, cast off the central 18 sts for the neck, k7.

Next row (WS): k7. Put remaining sts on a stitch holder, work will now be completed in 2 sections.

*Continue in G.st on these **7** sts. When work measures **59 cm (23 ¼ in) [126 rows]** total, cast off*.

With WS facing pick up sts left on stitch holder & repeat from *to* above.

FINISHING:

Sew the side seams of the sleeping bag (red lines on the diagram).

Sew on the buttons (see position on the diagram).

Secure & weave in all ends.

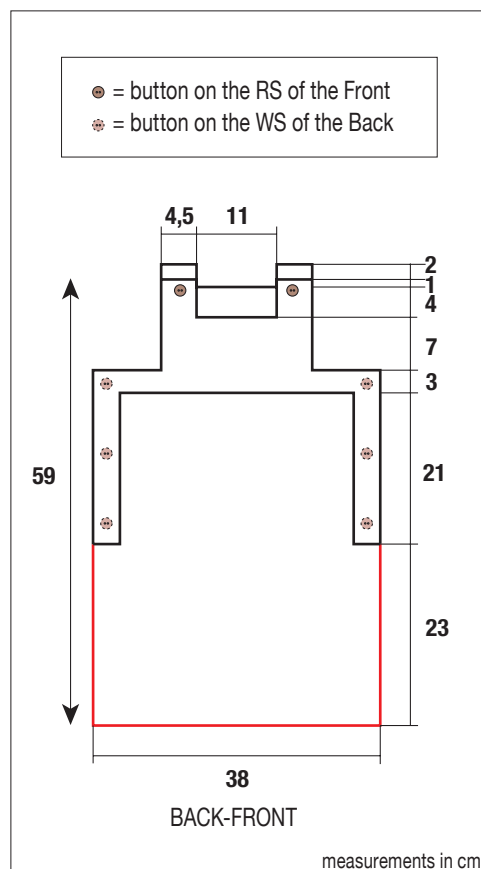

STRIPED SWEATER



Quality:
FILÉCO

Needles:
4.5 & 5.0 mm
5.0 mm long
double pointed
needles or circular needles



Accessories:
3 yellow buttons 13mm. ref. 64786 (pk of 7)
Blue sewing thread (not sold)

Sizes	4 yrs	6 yrs	8 yrs	10 yrs	12 yrs
Quality FILÉCO	Number of balls				
Ecobleu (A) 54640	4	5	5	6	7
Ecoocre (B) 54723	1	2	2	2	2

Stitches used

1/1 RIB, using 4.5 mm needles.

STOCKING ST (St st), using 5.0 mm needles.

STRIPED ST ST, 5.0 mm double pointed needles (or circular needles): work 1 row col B, 3 rows col A, rep these 4 rows (using double pointed needles enables you to continue without having to break the yarn).

Tension/Gauge

To achieve a good result it is essential to make a tension square (see "Check Your Tension" instructions at beginning of book).

16 sts & 20 rows over St st using 5.0 mm needles = 10 cm (4 in) square.

To make

BACK:

Using 4.5 mm needles & col A CO **51-57-61-65-69** sts.

Row 1 (RS): *k1, p1, rep from * to last st, k1.

Row 2: *p1, k1, rep from * to last st, p1.

These 2 rows form 1/1 rib, rep until work measures **3 cm (1 in) [8 rows]** total, **but** on the final row, **for sizes 4 yrs – 10 yrs & 12 yrs** inc 1 st (= **52-57-61-66-70** sts).

Change to 5.0 mm double pointed needles or circular needles and cont as folls:

4 yrs – 8 yrs & 12 yrs: 2 rows St st in col A, then cont in **Striped St st**.

6 yrs & 10 yrs: **Striped St st**.

Armholes:

When work measures **24-27-30-33-36** cm (**9½-10½-11¼-13-14** in) [**50-56-62-68-74** rows] total cast off: **2-3-3-3-3** sts at beg of next **4-2-2-2-2** rows, **0-2-2-2-2** sts at beg of foll **0-2-2-2-2** rows, 1 st at beg of foll **2-2-2-4-4** rows.

Cont on the rem **42-45-49-52-56** sts until work measures **28.5-31.5-34.5-37.5-40.5** cm (**11¼-12½-13½-14¾-16** in) [**59-65-71-77-83** rows] total, after 1 row of col B, cont in St st using col A & 5.0 mm needles.

Shoulders & neck:

When work measures **38-42-46-50-54** cm (**15-16½-18-19½-21¼** in) [**78-86-94-102-110** rows] total cont as foll:

Next row (RS): Cast off **4-4-5-5-5** sts, **k11-12-12-13-14**, cast off the central **12-13-15-16-18** sts **for the neck**, work to end.

Next row (WS): Cast off **4-4-5-5-5** sts, work to cast off sts. Put rem sts on a stitch holder, work will now be completed in 2 sections.

***Next row (neck edge):** Cast off 2 sts, work to end. **9-10-10-11-12** sts rem.

Next row (shoulder edge): Cast off **4-5-5-5-6** sts, work to end. Work 1 row straight.

Cast off rem **5-5-5-6-6** sts*.

With WS facing pick up sts left on stitch holder & rep from *to* above.

FRONT:

Work the same as for Back to armhole shaping.

Armholes:

Cast off as for Back then cont on the rem **42-45-49-52-56** sts until work measures **28.5-31.5-34.5-37.5-40.5** cm (**11¼-12½-13½-14¾-16** in) [**59-65-71-77-83** rows] total, after 1 row of col B, cont in St st using col A & 5.0 mm needles.

Neck:

When work measures **35-39-43-46-50** cm (**13¾-15-17-18-19½** in) [**72-80-88-94-102** rows] total shape neck as foll:

Next row (RS): k**16-17-18-20-21**, cast off the central **10-11-13-12-14** sts for the neck, work to end.

Next row (WS): purl to cast off sts. Put rem sts on a stitch holder, work will now be completed in 2 sections.

*Cont to cast off at neck edge on next & every alt row: 2 sts once, 1 st **1-1-1-2-2** times. **13-14-15-16-17** sts rem*.

