

# le Wooling

SPECIAL ISSUE

*Orilis*



BERGERE  
DE FRANCE

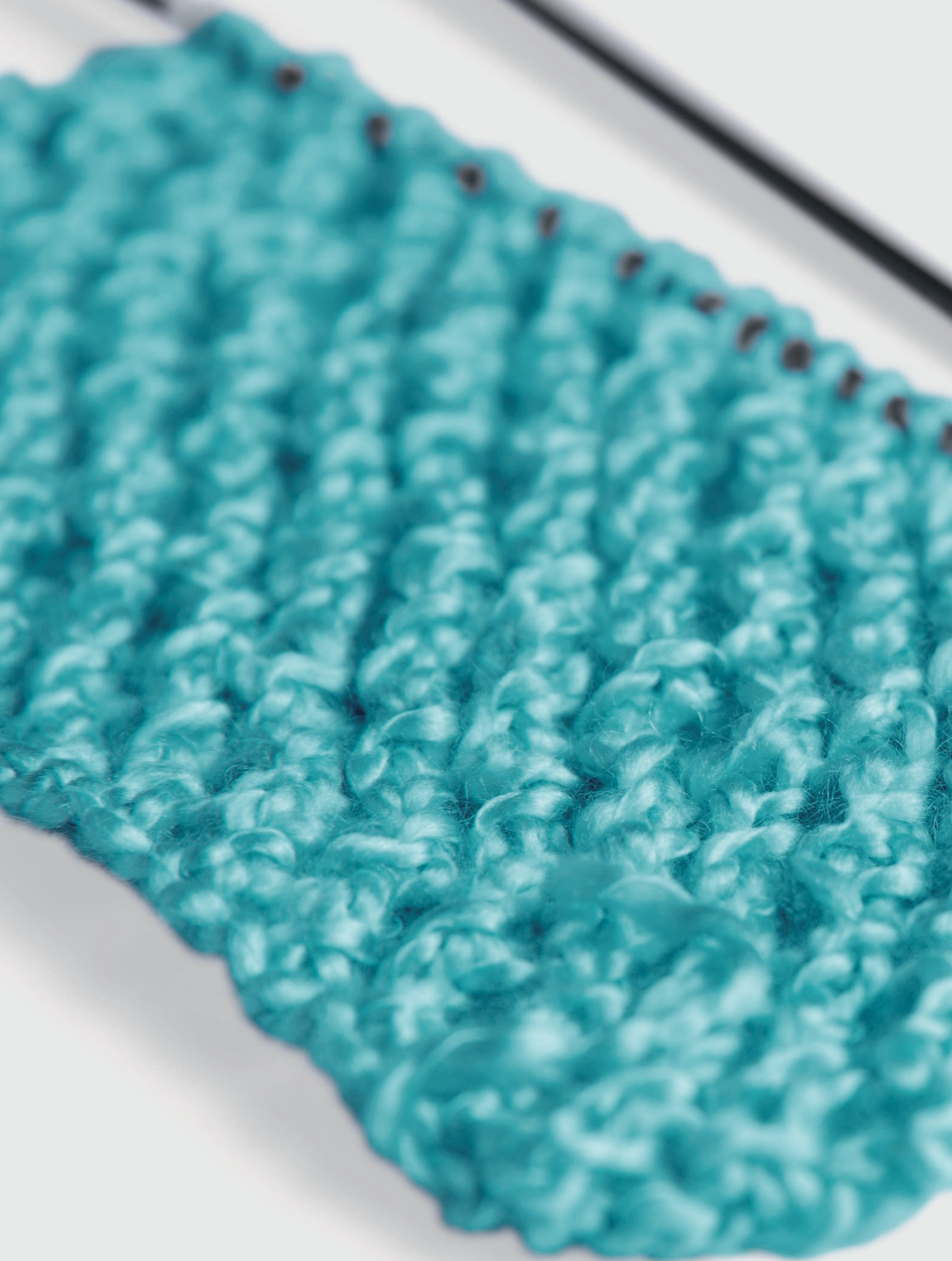

10 PATTERNS

# Orilis

Lightweight, ultra soft and flexible, this yarn is slightly wavy. It can be knitted for the whole family and is perfect for baby. Used in double yarn, this complements our winter range very well: you will be able to quickly produce mid-season creations.

## PRESENTATION

50g ball of yarn = 145 meters approximately



DK

## SHADES

Range of 12 shades (to discover on page 14).

## COMPOSITION

77% acrylic  
18% Tencel®  
5% polyester

## CARE INSTRUCTIONS

Machine wash, wool cycle.



01

TOP

Sizes **S M L XL XXL**

**ORILIS**

Pierre 4 5 5 6 6 balls

Needles 6.0 & 7.0 mm

**BBBBBB**  
EASY



02

¾ SLEEVE SWEATER

Sizes **S M L XL XXL**

**ORILIS**

Écru 7 8 8 9 10 balls

Needles 3.5 & 4.0 mm

Cable Needle

**BBBBBB**  
INTERMEDIATE



03

**STOLE****One size****ORILIS**

Sable 4 balls

Bois 3 balls

Noir 1 ball

Needles 6.0 mm

4 black buttons Ø 30 mm

ref. 55731

**BBBBBB**  
BEGINNER

04

SWEATER

Sizes S M L XL XXL

ORILIS

Astral 6 7 8 8 9 balls

Needles 3.5 & 4.0 mm

Stitch markers ref. 68395

BBBBBB  
INTERMEDIATE





05

PONCHO

One size

ORILIS

Sable 11 balls

Crochet hook 3.5 mm

**BBBBBB**  
INTERMEDIATE

06

**CROSS OVER****Sizes** S M L XL XXL**ORILIS**

Bordeaux 6 6 7 7 8 balls

Needles 4.0 mm

90 cm red grosgrain ribbon

10 mm ref. 30926

4 transparent press studs

13 mm ref. 60467

**BBBBBB**  
INTERMEDIATE

07

## CARDIGAN

Sizes	1	3	6	12 mths
-------	---	---	---	---------

**ORILIS**

Malabar	3	3	4	4 balls
---------	---	---	---	---------

Needles 6.0 mm

Stitch markers ref. 68395

3 pink printed 'heart' buttons

Ø 12 mm ref. 67871

**BBBBBB**  
EASY





08

## CROSS OVER

Sizes	4	6	8	10 yrs
-------	---	---	---	--------

**ORILIS**

Fraise	4	4	5	6 balls
--------	---	---	---	---------

Crochet hook 4.0 mm

Stitch markers ref. 68395

1 metre of pink reversible woven ribbon ref. 67859

**BBBBBB**  
 INTERMEDIATE



09

## T SWEATER

Sizes 4 6 8 10 12 yrs

## ORILIS

Ananas 3 4 5 5 6 balls

Crochet hook 4.0 mm

BBBBBB  
INTERMEDIATE

10

## SHORTS &amp; SWEATER

<b>Sizes</b>	<b>3 6 12 18 mths</b>
--------------	-----------------------

**ORILIS****SWEATER**

Pistache	1	2	2	2	balls
----------	---	---	---	---	-------

Tourmaline	1	2	2	2	balls
------------	---	---	---	---	-------

**SHORTS**

Tourmaline	2	2	2	2	balls
------------	---	---	---	---	-------

Needles 4

1 transparent press stud

10 mm ref. 60467

White elastic ribbon ref. 65635

**BBBBBB**  
EASY



# Orilis



ÉCRU  
20101



ANANAS  
20104



PISTACHE  
20103

## SHADES



SABLE  
20108



BOIS  
20110



BORDEAUX  
20102



FRAISE  
20121



MALABAR  
20109



PIERRE  
20111



ASTRAL  
20105



TOURMALINE  
20112



NOIR  
20107

# PATTERN INSTRUCTIONS

BERGERE  
DE FRANCE

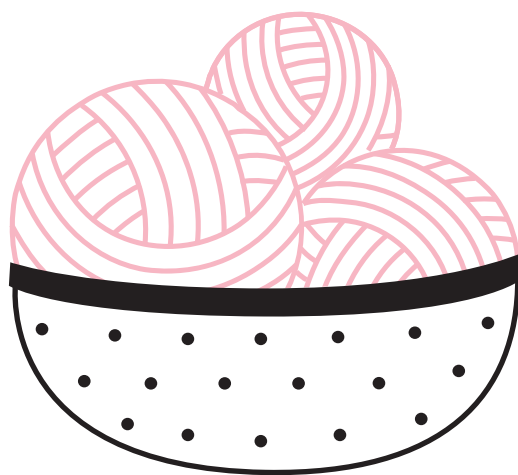

DON'T PANIC !

BERGERE DE FRANCE IS  
ACCOMPANYING ME STEP BY STEP



### OUR DEDICATED EMAIL

Stuck in the middle of your work? Need a clarification concerning the instructions? Do not hesitate to contact us. An expert knitter will take the time to provide the answers and all the help you need.

[knittingquery@bergeredefrance.com](mailto:knittingquery@bergeredefrance.com)

From Monday to Friday, during office hours



### OUR WEBSITE

[www.bergeredefrance.co.uk/knitting-basics-get-started](http://www.bergeredefrance.co.uk/knitting-basics-get-started)

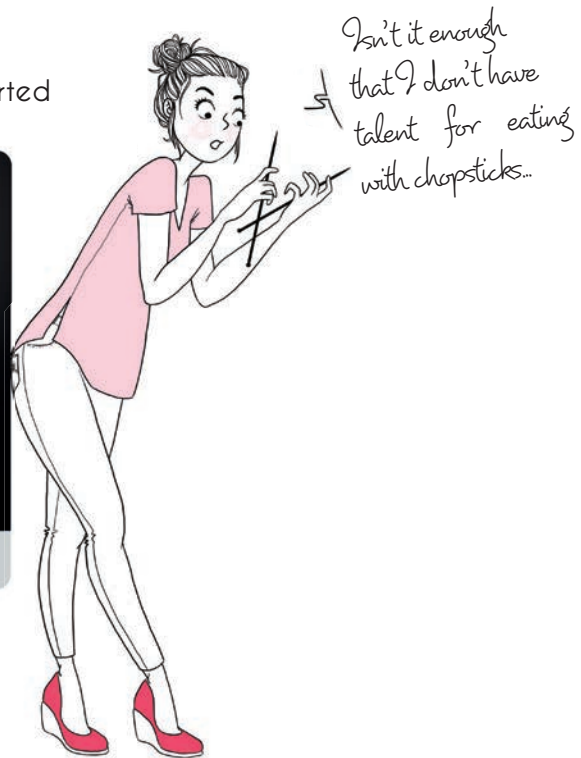
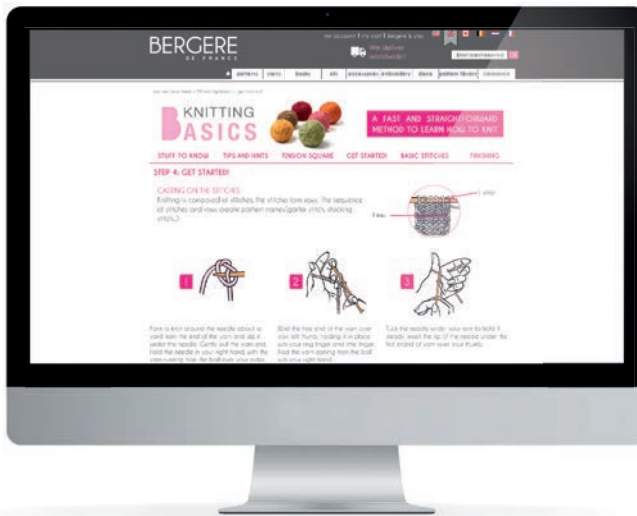

### OUR YOUTUBE CHANNEL

All our video tutorials (in french) are available at :  
[www.youtube.com/bergerefr](http://www.youtube.com/bergerefr)

Stuck in the middle of your work... Need some advice from an expert?



[knittingquery@bergeredefrance.com](mailto:knittingquery@bergeredefrance.com)

From Monday to Friday, during office hours

## CHECK YOUR TENSION

Before you start working on a pattern, make sure that the end-result will be perfect by making a swatch.

*You've got to make sure that your knitting tension is exactly the same as the tension in our pattern. If it isn't, your garment is likely to be too big or too small.*

### HOW TO MAKE A SWATCH ?

Using the yarn, needles, and stitch specified for the pattern, work a square at least 6 in (15 cm) on a side.

Iron the square lightly on the wrong side under a damp cloth or using a steam iron. If the swatch is worked in ribbing, stretch it slightly. With a ruler, count the sts to equal 4 in (10 cm) widthways and 4 in (10 cm) lengthways.

Compare the result with the sample given in our instructions.

#### *Your tension square matches ours !*

You can start your knitting, you can be sure your project will have the same dimensions as the grid.

#### *Your sample has more stitches and rows ?*

Your knitting is too tight. Make another swatch with needles one size larger.

#### *Your sample has fewer stitches and rows ?*

Your knitting is too loose. Make another swatch with needles one size smaller. When your swatch matches ours, you're ready to follow the instructions. You can expect to end up with a garment that's just right.

**BEWARE:** It is important to achieve an exact number of stitches for the design to fit correctly. However, the number of rows can be adapted depending on the height indicated in cm.



### Read the instructions

Before you start knitting we advise you to read through the instructions, trying to imagine all of the steps you will be taking. All patterns are well detailed.

The instructions are given for several sizes. We suggest that you circle or underline the numbers that correspond to the size you intend to make. If there's only one number, it applies to all the sizes.

## CASTING OFF THE STITCHES

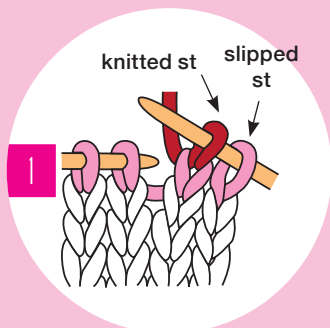

On the right side of work, slip 1 stitch onto the right needle as if to purl.

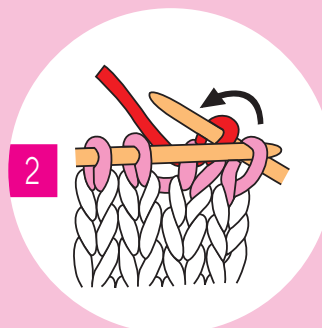

Using the left needle pass the slipped stitch over the top of the 2nd stitch on the right hand needle. You have cast off 1 stitch.

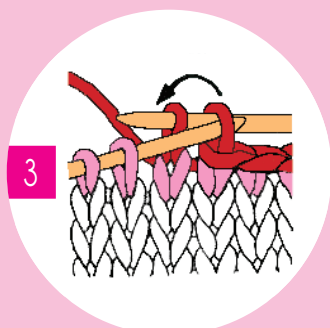

Knit the next stitch and with the left needle, pass the 1st stitch on needle over the top of the current stitch. One stitch remains on right needle.

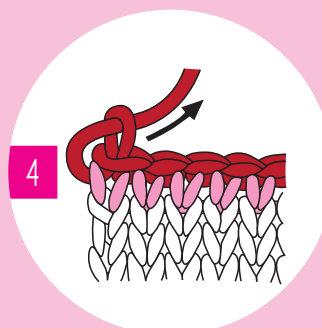

Repeat this sequence until all stitches from the left needle have been worked and only one stitch remains on right needle. Cut thread 10 cm from work and pull through remaining stitch using needle.

## WEAVING IN THE YARN

After sewing together the pieces you must weave in the loose ends. On the wrong side of the knitting using the yarn needle, slip the yarn end through a few stitches and then cut the yarn.

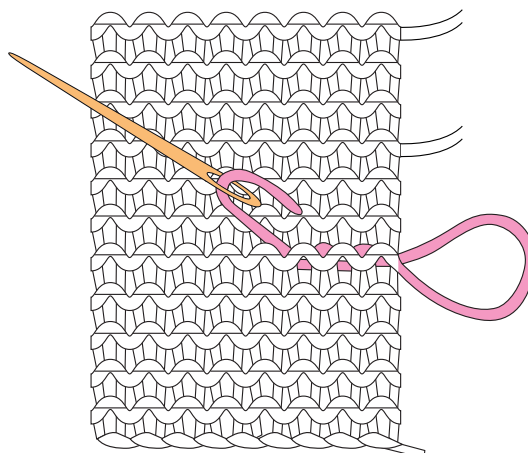

# BASIC KNITTING STITCHES

## 1/1 rib

Cast on an uneven number of stitches.

**Row 1 :** knit 1, purl 1, and repeat these 2 stitches to the last stitch, knit 1.

**Row 2 and subsequent rows :** purl over the purl stitches, knit over the knit stitches. Repeat these 2 rows.

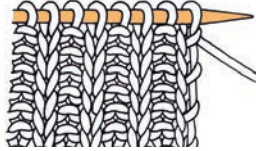

## Yarn forward

By bringing the yarn forward you add a stitch and make an eyelet.

Bring the yarn in front of the work then over the right-hand needle.

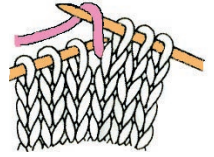

Work the next stitch on the left-hand needle. The yarn forward loop forms an extra stitch with a hold at its base on the right-hand needle.

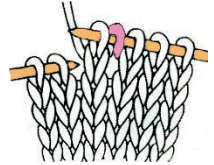

**Next row :** When you come to the yarn forward loop, purl it as you would any other stitch; you now have 1 extra stitch.

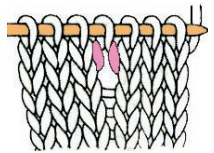

## 2/2 rib

Cast on a multiple of 4 stitches + 2 (e.g., 22 stitches).

**Row 1 :** knit 2, purl 2, and repeat to the last stitches, knit 2.

**Row 2 and subsequent rows :** purl over the purl stitches, knit over the knit stitches. Repeat these 2 rows.

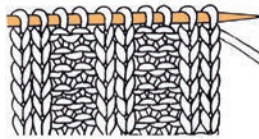

## Knit 2 together

Put the right needle through the 2nd then the 1st stitch on the left hand needle.

Knit the 2 stitches together (wrap yarn around right hand needle and pull through the 2 stitches on the left needle).

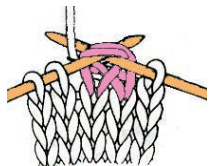
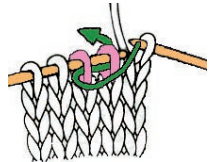

By knitting 2 stitches together you will have 1 less stitch on the needle..

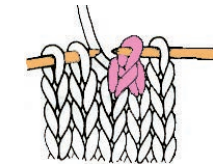

## Seed or moss stitch

Cast on an uneven number of stitches.

**Row 1 :** knit 1, purl 1, repeat these 2 stitches.

**Row 2 and subsequent rows :** purl over knit stitches, knit over purl stitches.

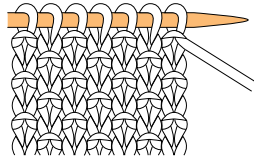

## Slipped stitch

With the yarn at the back of the work, insert the right-hand needle into the next stitch from right to left, as if to purl. Slip the stitch on to the right-hand needle and continue working as given.

**Next row :** Purl the slipped stitch.

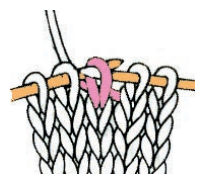

## Corn stitch

Cast on an uneven number of stitches.

**Row 1 :** knit 1, purl 1, repeat these 2 stitches, ending with knit 1.

**Row 2 :** purl over purl stitches, knit over knit stitches.

**Row 3 :** purl over knit stitches, knit over purl stitches.

**Row 4 :** purl over purl stitches, knit over knit stitches. Repeat these 4 rows.

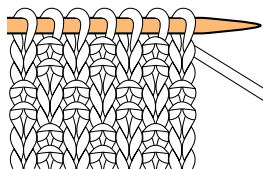

## Single decrease

Slip a stitch on to the right-hand needle as if to knit.  
Knit the next stitch.

Using the left-hand needle, pass the slipped stitch over the stitch you just worked.

After working a single decrease, you have 1 less stitch on the needle.

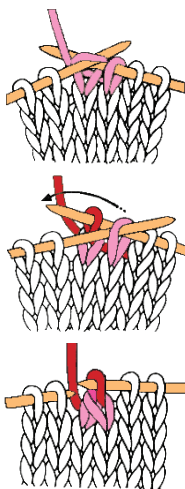

## Double decrease

Slip a stitch on to the right-hand needle as if to knit.  
Knit the next 2 stitches together.

Using the left-hand needle, pass the slipped stitch over the 2 stitches you just worked.

After working a double decrease, you have 2 fewer stitches on the needle.

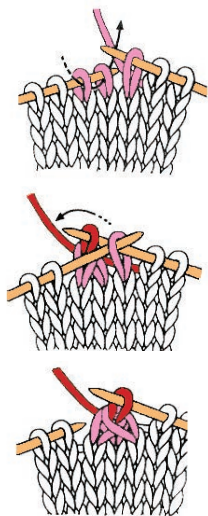

## Twisted knit stitch

Knit the stitch, inserting the needle through the back loop to twist the new stitch.



## Twisted purl stitch

Purl the stitch, inserting the needle under the back loops to twist the new stitch.



## Nonstitch or suppressed stitch

Sometimes, the number of stitches varies from row to row in a pattern; the nonstitches or suppressed stitches are represented by black squares on the chart. When you follow the chart, do not try to work the black squares but go directly to the next square.

## Working in reverse

When instructed on the front of a garment, for example a jacket, to work the other front in reverse. If you increased or decreased at the beginning of a right side row on the first front you must increase or decrease at the end of the right side row on the second front at the same measurement. The positions of the stitches used will also be reversed, if you ended with a ribbed section for a border on the first front you will start with the ribbed section on the second front. However the pattern should remain the same (do not reverse a cable twist for example).

## Double decrease slip slip knit

Slip 2 stitches as if to knit. Knit 1.  
Pass the 2 slipped stitches over the stitch just worked..

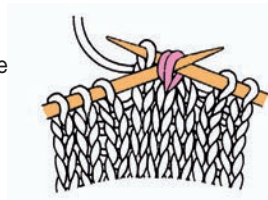

## Raglan decreases

This method of decreasing is always used for Raglan sleeves. It forms a line of slanting stitches parallel with the seam. The decrease is worked with the right side facing, one or more stitches from the edge.

The example shows decreases 1 stitch from the edge :

At beginning of row, with right side facing, knit 1, slip 1, knit 1, pass slipped stitch over (See above).

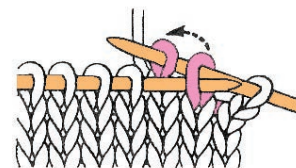

Continue the row as indicated. When 3 sts are left on the left-hand needle, knit the next 2 sts together (see knit 2 together, page 7), knit the last stitch.

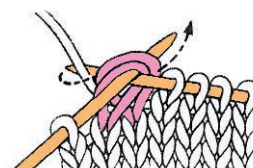

## Cables

It is easy to work narrow cables over 2 stitches :

**Right cross 2 (2CR):** Passing in front of the work, knit the 2nd st on the left-hand needle then knit the first stitch; slip both stitches on to the right-hand needle at once.

**Left cross 2 (2CL):** Passing behind the work, knit the 2nd st on the left-hand needle then knit the first stitch as usual; slip both stitches on to the right-hand needle at once.

A cable made up of 3 or more stitches requires the use of a cable needle.

### Cable 4 left (front) :

Slip 2 stitches on to a cable needle in front of work, knit 2, then slip the 2 stitches from the cable needle on to the left-hand needle and knit 2.

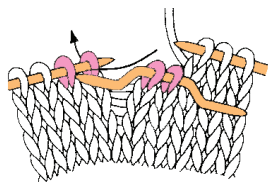

### Cable 4 right (back) :

Slip 2 stitches on to a cable needle at back of work, knit 2, then slip the 2 stitches from the cable needle on to the left-hand needle and knit 2.

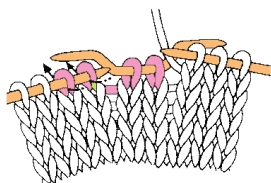

## Picking up stitches

When the different sections of the garment are completed, you may need to pick up stitches at the edge of your work, for example on the collar or front borders

To pick up the stitches knit wise, put needle through the middle of each stitch on the last row and pick up the loop. When you are picking up stitches on rows where there are more rows than stitches required work through 2 or 3 rows then skip 1 row to obtain the number of stitches required in the pattern.

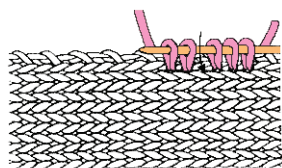
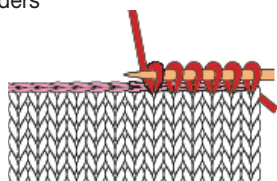

## Backstitched seam

Place the 2 pieces right sides together. Thread a tapestry needle with the matching yarn, insert the needle through both thicknesses, matching stitch for stitch, and bring the needle out 2 rows further along.

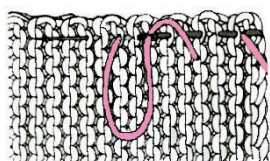

## Grafting

This technique is widely used in European patterns, but is not so popular among UK and US knitters. When you have completed the sections, do not cast off, but leave the stitches on a spare needle.

Thread a tapestry needle with the matching yarn. Work with right side facing. Place the 2 spare needles together.

Insert the tapestry needle through the centre of the first stitch on the front needle as if to purl (leave the stitch on the needle),

– and bring the tapestry needle out at the centre of the first stitch on the back needle as if to knit (leave the stitch on the needle),

\*bring the tapestry needle through the center of the first stitch on the front needle again as if to knit and slip off the stitch,

– Insert the tapestry needle through the centre of the next stitch on the front needle as if to purl (leave the stitch on the needle),

– bring the tapestry needle out at the center of the next (first) stitch on the back needle again as if to purl and slip off the stitch,

– Insert the tapestry needle through the center of the next stitch on the back needle as if to knit (leave the stitch on the needle)\*, maintaining an even tension. Repeat the movement until the seam is complete.

Work all the free stitches into the seam one by one and let the stitches drop off the spare needles as they are grafted together.

The finished seam will look identical to a row of knitting.

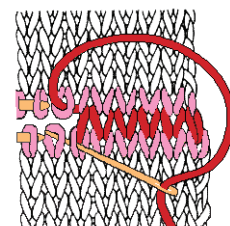
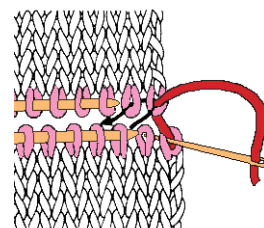

## Invisible seam

Following the sketch, working with the 2 pieces to be joined, pick up the horizontal thread between the first and second stitches and pull firmly to bring the edges together and make the join invisible. If the edge is very uneven, work the thread between the second and third stitches.

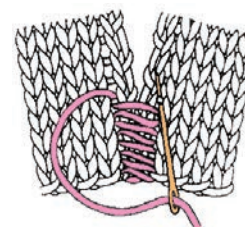

You may also use an invisible seam to join at the shoulder. In that case, pick up the 2 upright strands of a stitch 1 row in from the edge.

## Fair Isle

Fair Isle and contrasting colour patterns.

These patterns are worked in stocking stitch using several colours to make a design shown on a chart.]

Each square on the chart represents 1 stitch and 1 row. A legend accompanying the chart indicates the colours. Read the chart beginning at the bottom row, from right to left for the right side of the work, and from left to right for the wrong side rows.

### KNITTED PATTERNS

Various techniques are used according to the complexity of the pattern.

- When the motifs of the design are small and close together, you may let the yarn not in use run loosely at the back of the work. Make sure that you don't pull the yarn taut or it will pucker the pattern.
- When the motifs are far apart or very wide, pass the yarn not in use behind the work attaching it along with the one that is in use : hold the yarn not in use in your left hand, then work a stitch passing the right-hand needle under that yarn but taking care not to actually knit the yarn. Repeat this movement every other stitch.
- When the motifs are very large or use several colours, do not try to pass the yarn at the back of the work. Instead, use several balls of each colour, as needed, using the intarsia technique. Each time you change yarn colour, make sure that you twist the yarns loosely at the back of the work to avoid forming holes in the texture.

In all three cases, take care to work evenly, especially where the colours change and stitches tend to be loose.

### EMBROIDERED PATTERNS

Embroidery can be used to advantage instead of knitted patterns when the motifs are made up of relatively few stitches.

This technique avoids the problems of disposing of extra yarns at the back of the work. For embroidery, form open chain stitch with a tapestry needle, working from right to left.

Bring the needle from wrong side to right side at the base of the first stitch, insert the needle from right to left under both strands of the stitch above the one being worked (see sketch no. 1), then insert the needle again at the base of the stitch being worked and bring it out at the base of the next stitch (see sketch no. 2).

Use this technique to embroider the number of stitches indicated. After the last stitch, bring the needle out at the base of the row above. Turn the work to start again from right to left.

Sketch no 1

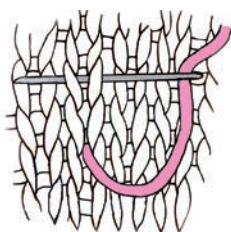

Sketch no 2

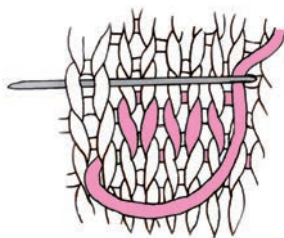

## Grafting a border

When the border is finished, work a few rows of stocking stitch using a contrasting yarn.

Take the work off the needle and press the stocking stitch section with a warm iron under a damp cloth to prevent it from unraveling. Pin the border to the finished garment, matching the stitches. Unravel all but the last row of stocking stitch. Now graft the stitches, waving the tapestry needle in and out, and unravel the last row of stocking stitch as you go. Bring the needle from back to front through the centre of the second stitch, work a back stitch into the first stitch and bring the needle out again at the centre of the third stitch; now work a backstitch again into the second stitch and continue thus with backstitching as far as the last stitch.

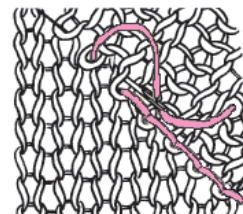

## Chainstitch shoulder seam

### CHAINSTITCH SHOULDER SEAMS

or 3 needles cast off or 3 needles bind off

Leave the remaining shoulder stitches on a spare needles. Place back and front with wrong sides together.

Using a third needle, knit together the first stitch from the front needle with the first from the back needle, and repeat with the second stitch from each needle. You now have 2 stitches on the right-hand needle.

Pass the first stitch over the second, as in casting off. Continue thus until you have cast off all the shoulder stitches. The result is a chain that shows on the right side and a shoulder seam that will not go out of shape. To obtain an invisible seam on the right side, place back and front with right sides together.



# BASIC CROCHET STITCHES

## Chain stitch (ch or ch st)

The first stitch in crochet. Make a loop. Insert the hook in the loop. \* Pass the hook under the yarn for a yarn over (yo), and pull the yo through the loop = 1 ch st. Rep from \* to work as many ch sts as needed.

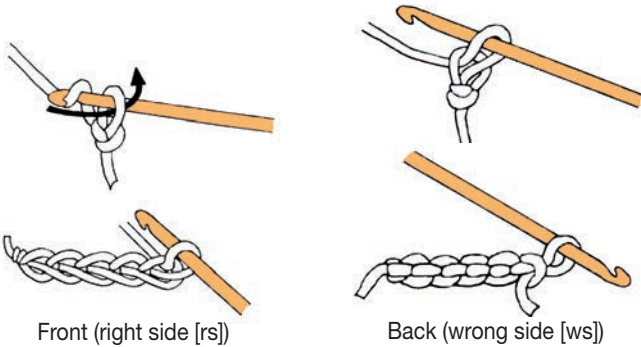

## Slit stitch (sl st)

Insert the hook into a stitch, yo and pull through the loop on the hook in a single movement.

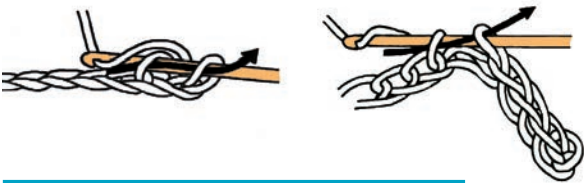

## Single Crochet (

UK: Double Crochet) = sc (uk: dc)

Insert the hook into a stitch, yo and draw up loop, yo and through both loops on hook.

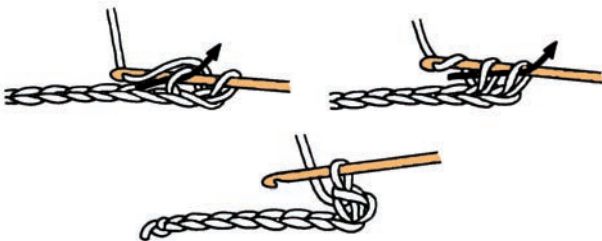

## Crab Stitch (sc (uk: dc) worked from left to right)

Beg at left edge: \* insert hook into a stitch, yo and draw up lp, yo and through both lps on hook \*, rep from \* to \*, inserting hook into preceding st..

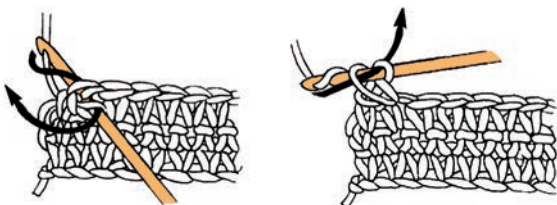

## Half Double Crochet

(UK: Half Treble) = hdc (uk: half tr)

Yo, insert the hook into a stitch, yo and draw up loop, yo and through all 3 loops.

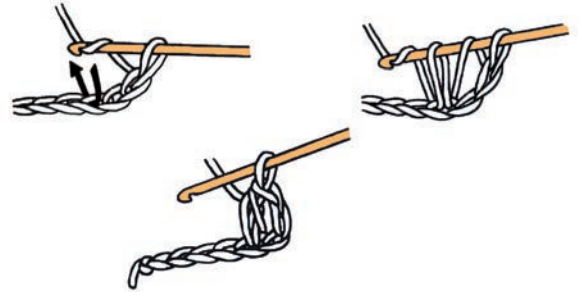

## Double Crochet

(UK: Treble) = dc (uk: tr)

Yo, insert the hook into a st, yo and draw up loop, yo and through first 2 loops on hook, yo and through remaining 2 loops.

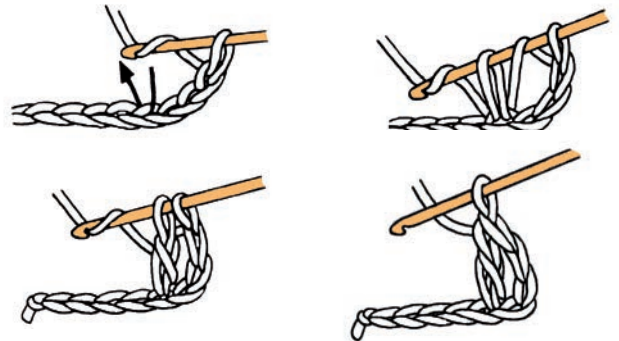

## Treble (UK: Double Treble) = tr (uk: dbl tr)

Yo twice, insert the hook into a stitch, yo and draw up loop, yo and through first 2 loops on hook, yo and through 2 loops on hook, yo and through remaining 2 loops.

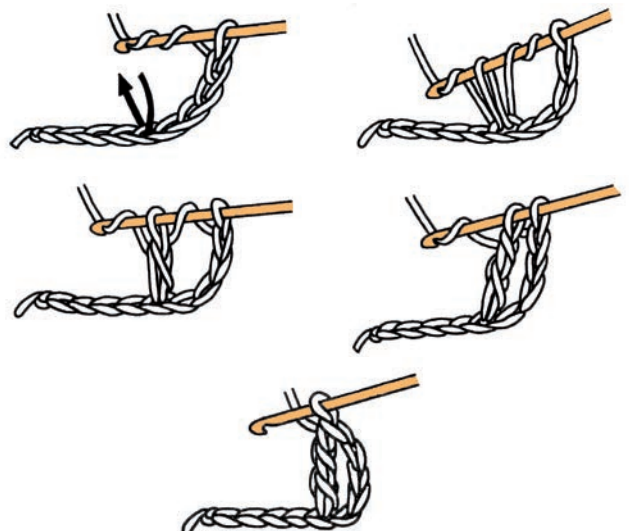

## Double Treble

(UK: Triple Treble) = dbl tr (uk: tr tr)

Yo 3 times, insert the hook in a stitch, yo and draw up loop, yo and through first 2 loops on hook, yo and through 2 loops on hook, yo and through 2 loops on hook, yo and through remaining 2 loops.

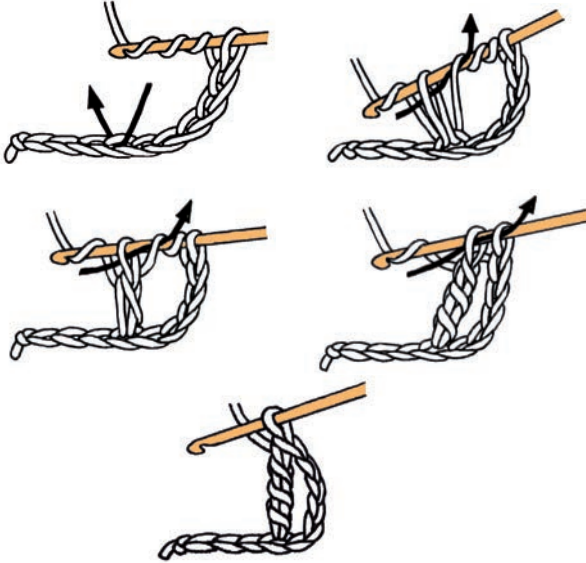

## Beginning with a round

Wind the yarn around the tip of your index finger, slip the hook through the loop, yo and draw up lp, yo and through the loop as shown, then work as many dc as indicated. To end the first round, work a sl st over the first dc and pull gently but firmly on the end of yarn to close up the initial ring..

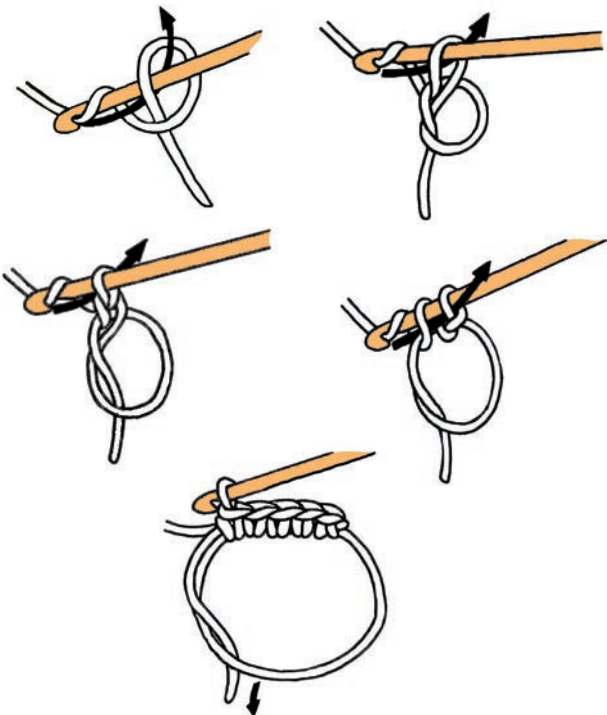

## 2 Single Crochet Together (UK: 2 Double Crochet Together) = 2 sc tog (uk: 2 dc tog)

Leaving last loop of each st on the hook, work incomplete sc as follows: Insert hook into a st, yo and draw up loop, insert hook into next st, yo and draw up loop, yo and through all remaining 3 loops.

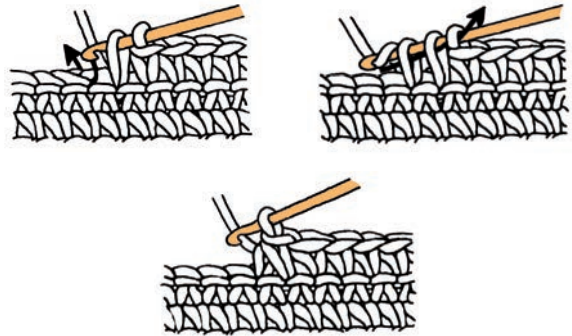

## 3 single crochets together (3 sc tog) [3 double crochets together : 3 dc tog (UK)]

Leaving last loop of each stitch on the hook, work incomplete sc as follows; insert hook in a stitch, yo and draw up loop, insert hook in next stitch, yo and draw up loop, insert hook in next stitch, yo and draw up loop, yo and through all remaining 4 loops at once.

## 2 Double Crochets Together

(UK: 2 Trebles Together) = 2 dc tog (uk: 2 tr tog)

Leaving last loop of each st on the hook, work incomplete dc as follows : yo, insert the hook into a st, yo and draw up loop, yo and through first 2 loops on hook, yo, insert hook into next st, yo and draw up loop, yo and through first 2 loops, yo \* and through all 3 remaining loops.

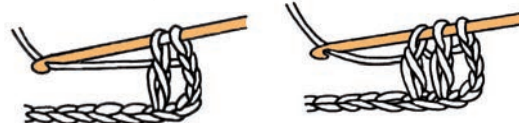

## 3 Double Crochets Together (UK: 3 Trebles Together) = 3 dc tog (uk: 3 tr tog)

As for 2 dc tog as far as \*, then insert hook into next st, yo and draw up loop, yo and through 2 loops on hook, yo and through all 4 remaining loops.

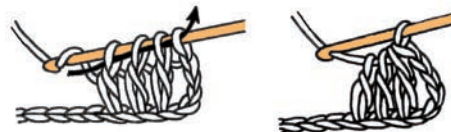

## 2 or 3 Double Crochets Together (UK: 2 or 3 Trebles Together) = 2 or 3 dc tog (uk: 2 or 3)

As for dc tog (tr tog), but beg by working yo twice.



Quality: **ORILIS**  
Needles: **6.0 & 7.0 mm**

Sizes		S	M	L	XL	XXL
Quality <b>ORILIS</b>		Number of balls				
Pierre	20111	4	5	5	6	6

**Shoulder:**

Cont on the rem **5-6-6-7-8** sts until work measures **56-58-60-62-64** cm (**22-22½-23½-24½-25¼** in) [**78-82-84-88-92** rows] total then cast off all sts.

With WS facing pick up sts left on stitch holder. Cast off 2 sts at beg of next WS row, then 1 st at beg of next WS row for the neck.

Cont on the rem **5-6-6-7-8** sts until work measures **56-58-60-62-64** cm (**22-22½-23½-24½-25¼** in) [**78-82-84-88-92** rows] total then cast off all sts for the shoulder.

**FRONT:**

Work as for Back until work measures **37-38-38-39-40** cm (**14½-15-15-15¼-15¾** in) [**52-54-54-56-58** rows] total. **47-52-56-63-68** sts rem.

**Armholes & Neck:**

**Next row (RS):** Cast off **3-3-4-5-6** sts, work **20-23-24-26-28** sts, cast off **1-0-0-1-0** sts, put rem **23-26-28-31-34** sts on a stitch holder. Work will now be completed in 2 sections.

**Next row (WS):** Work 1 row straight.

**Next row (RS – dec):** k3, k2tog, work to last 5 sts, sl 1, k1, pssso, k3.

Rep this dec on every foll RS row **4-5-5-6-6** times. **10-11-12-12-14** sts rem.

**Next row (RS- dec):** Work to last 5 sts, sl 1, k1, pssso, k3.

Rep this dec on every foll RS row **4-4-5-4-5** times.

**Shoulder:**

Cont on the rem **5-6-6-7-8** sts until work measures **56-58-60-62-64** cm (**22-22½-23½-24½-25¼** in) [**78-82-84-88-92** rows] total then cast off all sts.

With RS facing pick up the **23-26-28-31-34** sts left on stitch holder and work 1 row straight.

**Next row (WS):** Cast off **3-3-4-5-6** sts. **20-23-24-26-28** sts rem.

**Next row (RS – dec):** k3, k2tog, work to last 5 sts, sl 1, k1, pssso, k3.

Rep this dec on every foll RS row **4-5-5-6-6** times. **10-11-12-12-14** sts rem.

**Next row (RS- dec):** k3, k2tog, work to end.

Rep this dec on every foll RS row **4-4-5-4-5** times.

Cont on the rem **5-6-6-7-8** sts until work measures **56-58-60-62-64** cm (**22-22½-23½-24½-25¼** in) [**78-82-84-88-92** rows] total then cast off all sts for shoulder.

**FINISHING:**

Join shoulder seams.

Sew the side seams.

Allow the base of the Top to roll up.

Secure & weave in all ends.

● **Stitches used**

**STOCKING STITCH (St st)**, using 6.0 mm & 7.0 mm needles.

**Row 1 (RS):** knit. **Row 2:** purl.

Rep these 2 rows.

● **Tension/Gauge**

To achieve a good result it is essential to make a tension square (see “Check Your Tension” instructions at beginning of book).

12 sts & 14 rows over St st using 7.0 mm needles = 10 cm (4 in) square.

● **To make**

**BACK:**

Using 6.0 mm needles CO **55-60-64-71-76** st. Starting with a knit row work in St st for **2.5** cm (1 in) [**4** rows].

Change to 7.0 mm needles & cont until work measures **8.5** cm (**3¼** in) [**12** rows] total.

**Next row (RS – dec):** k2, k2tog, work to last 4 sts, sl 1, k1, pssso, k2.

Rep this dec on every foll 10th row 3 more times.

Then cont on the rem **47-52-56-63-68** sts until work measures **37-38-38-39-40** cm (**14½-15-15¼-15¾** in) [**52-54-54-56-58** rows] total.

**Armholes:**

Cast off **3-3-4-5-6** sts at beg of next 2 rows. **41-46-48-53-56** sts rem.

**Next row (RS – dec):** k3, k2tog, work to last 5 sts, sl 1, k1, pssso, k3.

Rep this dec on every foll RS row **4-5-5-6-6** more times.

After the final dec cont on the rem **31-34-36-39-42** sts until work measures **52-54-56-58-60** cm (**20½-21¼-22-22½-23½** in) [**72-76-78-82-86** rows] total.

**Neck:**

**Next row (RS):** Work **8-9-9-10-11** sts, cast off the central **15-16-18-19-20** sts, work to end.

**Next row (WS):** Work to cast off sts, put rem sts on a stitch holder. Work will now be completed in 2 sections.

Cast off 2 sts at beg of next RS row, then 1 st at beg of next RS row for the neck.

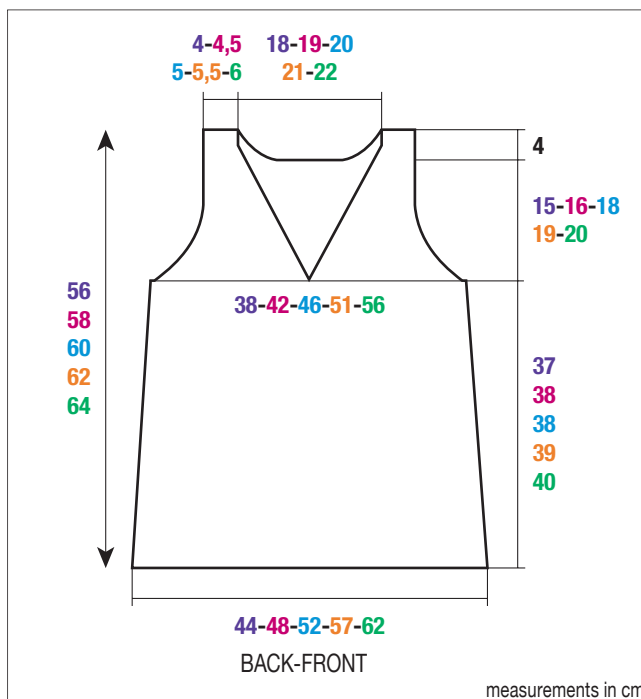

# ¾ SLEEVE SWEATER



Quality:  
**ORILIS**

Needles:  
**3.5 & 4.0 mm**  
Cable Needle (cn)

Sizes		S	M	L	XL	XXL
Quality <b>ORILIS</b>		Number of balls				
Ecru	20101	7	8	8	9	10

## ● Abbreviations

**Right Cross** = CR

**Left Cross** = CL

**4CR:** Slip 2 sts onto cn at back of work, k2, then k2 from cn

**4CL:** Slip 2 sts onto cn at front of work, k2, then k2 from cn

## ● Stitches used

**GARTER STITCH (G.st)**, using 3.5 mm needles.

**PATTERN STITCH (Patt St)**, using 4.0 mm needles. Over a number of sts divisible by 3 (+2).

**Row 1 (RS) & 3:** k2, \*p1, k2\* rep from \*to\*.

**Row 2:** p2, \*k1, p2\* rep from \*to\*.

**Row 4:** knit.

After Row 4 rep from Row 1.

**REVERSE STOCKING STITCH (Rev St st) & STOCKING STITCH (St st)**, using 4.0 mm needles.

**CABLE**, using 4.0 mm needles. Over 8 sts.

**Row 1 (RS) & 3:** knit.

**Row 2 & every WS row:** purl.

**Row 5:** 4CR, 4CL.

**Row 7 & 9:** purl.

After Row 10 rep from Row 5.

## ● Tension/Gauge

To achieve a good result it is essential to make a tension square (see "Check Your Tension" instructions at beginning of book).

22 sts & 32 rows over Pattern St using 4.0 mm needles = 10 cm (4 in) square.

## ● To make

### BACK:

Using 3.5 mm needles CO **128-138-146-158-168** sts.

Work in G.st for 2 rows.

Change to 4.0 mm needles & work as foll:

**27-29-33-36-41** sts Pattern St starting as foll:

**S, L & XL:** From Stitch 3 on the Chart

**M & XXL:** From Stitch 1 on the Chart

**2** sts Rev St st,  
**8** sts Cable,  
**2** sts Rev St st,  
**14-17-17-20-20** sts Pattern St,  
**2** sts Rev St st,  
**8** sts Cable,  
**2** sts Rev St st,  
**8** sts Cable,  
**2** sts Rev St st,  
**14-17-17-20-20** sts Pattern St,  
**2** sts Rev St st,  
**8** sts Cable,  
**2** sts Rev St st,  
**27-29-33-36-41** sts Pattern St.

Cont as est until work measures **4 cm (1½ in)** [12 rows] total.

**Next row (RS – dec):** patt 2 sts, k2tog or p2tog, work to last 4 sts, sl 1, k1, pssso or p2tog, patt 2 sts.

Rep this dec on every foll 8th row **5-5-5-8-8** times, then on every foll 6th row **3-3-3-0-0** times.

Then cont on the rem **110-120-128-140-150** sts until work measures **24-25-25-26-27 cm (9½-9¾-9¾-10¼-10½ in)** [78-80-80-84-88 rows] total.

### Raglan:

Cast off **2-3-3-5-8** sts at beg of next 2 rows. **106-114-122-130-134** sts rem.

Work **2-2-2-0-0** rows straight. Then dec for raglan as foll working the first & last 4 sts as St st.

**Next row (RS – dec):** k3, k2tog, work to last 5 sts, sl 1, k1, pssso, k3.

**Next row (WS):** p4, patt to last 4 sts, p4.

Work **2-0-0-0-0** rows straight.

Rep the dec on every foll RS row **26-29-32-35-36** times.

After the final raglan dec work 1 row on the rem **52-54-56-58-60** sts, then cast off all sts for neck.

### FRONT:

Work as for Back until raglan shaping.

### Raglan:

Cast off **2-3-3-5-8** sts at beg of next 2 rows. **106-114-122-130-134** sts rem.

Work **2-2-2-0-0** rows straight. Then dec for raglan as foll working the first & last 4 sts as St st.

**Next row (RS – dec):** k3, k2tog, work to last 5 sts, sl 1, k1, pssso, k3.

**Next row (WS):** p4, patt to last 4 sts, p4.

Work **2-0-0-0-0** rows straight.

Rep the dec on every foll RS row **23-26-29-32-33** times, **but at the same time**, when work measures **38-40-42-44-46 cm (15-15¼-16½-17¼-18 in)** [122-128-134-142-148 rows] total, cast off the central **34-36-38-40-42** sts for the neck, then cont each side separately, casting off at the next edge on every alt row as foll: 3 sts once, 2 sts once, 1 st twice & the rem 5 sts.

### LEFT SLEEVE:

Using 3.5 mm needles CO **80-88-94-104-112** sts. Work in G.st for 2 rows.

Change to 4.0 mm needles & cont as foll:

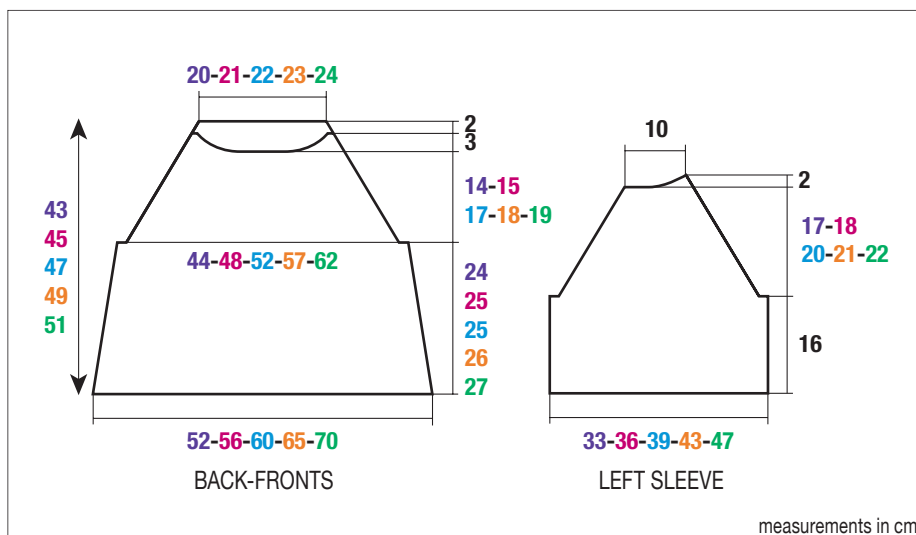

**18-22-25-30-34** sts Patt St starting as foll:

**S & XL:** From St 3 of Chart,

**M, L & XXL:** From St 2 of Chart,

**2** sts Rev St st,

**8** sts Cable,

**2** sts Rev St st,

**20** sts Patt St,

**2** sts Rev St st,

**8** sts Cable,

**2** sts Rev St st,

**18-22-25-30-34** sts Patt St.

Cont in patt as est until work measures **16 cm** (**6¼ in**) [**52 rows**] total.

### Raglan:

Cast off **2-3-3-5-8** sts at beg of next 2 rows.

Work **2-2-2-0-0** rows straight. Then dec for raglan as foll working the first & last **4** sts as St st.

**Next row (RS – dec):** k3, k2tog, work to last 5 sts, sl 1, k1, pss0, k3.

**Next row (WS):** p4, patt to last 4 sts, p4.

Work **2-0-0-0-0** rows straight.

Rep the dec on every foll RS row **23-26-29-32-33** times. 28 sts rem.

**Next row (RS):** k3, k2tog, work to end. 27 sts rem.

**Next row (WS):** Cast off 15 sts, work to end. 12 sts rem.

**Next row (RS):** k3, k2tog, work to end. 11 sts rem.

**Next row (WS):** Cast off 3 sts, work to end. 8 sts rem.

**Next row (RS):** k3, k2tog, work to end. 7 sts rem.

**Next row (WS):** Cast off 2 sts, work to end. 5 sts rem.

Cast off the rem **5** sts.

### RIGHT SLEEVE:

Work as for Left Sleeve until 28 sts rem.

**Next row (RS):** Cast off 15 sts, work to last 5 sts, sl 1, k1, pss0, k3. Work 1 row straight. 12 sts rem.

**Next row (RS):** Cast off 3 sts, work to last 5 sts, sl 1, k1, pss0, k3. Work 1 row straight. 8 sts rem.

**Next row (RS):** Cast off 2 sts, work to last 5 sts, sl 1, k1, pss0, k3. Work 1 row straight. 5 sts rem.

Cast off the rem **5** sts.

### FINISHING:

Join the raglan seams leaving the raglan between the Back & the Right sleeve open.

#### Neck border:

- With RS facing & 3.5 mm needles pick up **128-132-136-140-144** sts around neck edge.

- Work **1** row of knit on the WS of work.

- Cast off all sts purlwise on the RS of work.

Join the final raglan seam & the edge of the border.

Sew side & sleeve seams.

Secure & weave in all ends.

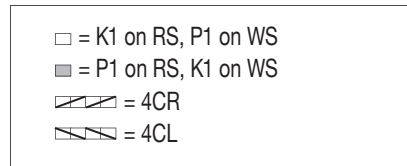
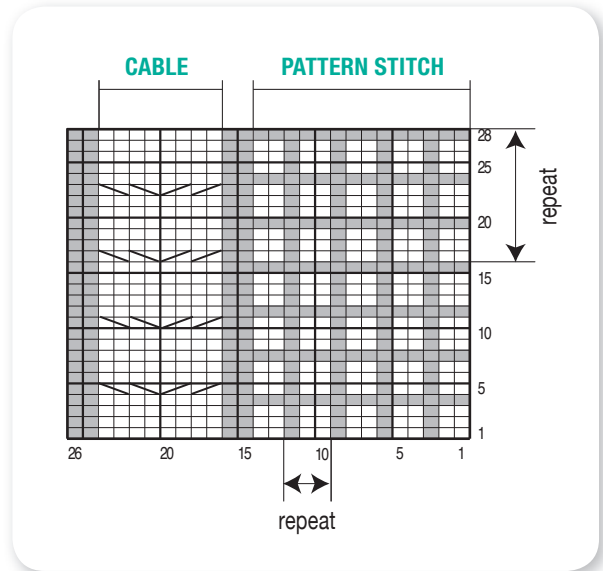

# 3 STOLE



Quality:  
**ORILIS**



Needles:  
**6.0 mm**  
**1 x Wool Needle (for sewing in ends)**



Accessories:  
**4 black buttons Ø 30 mm**  
**ref. 55731 (pk of 6)**

## One Size

Quality <b>ORILIS</b>		Number of balls
Sable (A)	20108	4
Bois (B)	20110	3
Noir (C)	20107	1

## ● Abbreviations

**k1tbl**: knit the next stitch by knitting into the back of the loop instead of the front.

## ● Stitches used

**TWISTED GARTER STITCH (G.st)**, using 6.0 mm needles.

Work all sts on all rows as k1tbl

## ● Tension/Gauge

To achieve a good result it is essential to make a tension square (see "Check Your Tension" instructions at beginning of book).

17 sts & 23.5 rows over Twisted Garter St using 6.0 mm needles = 10 cm (4 in) square.

## ● To make

Using 6.0 mm needles & col B cast on **89** sts.

Work in Twisted G.st as foll:

- **39** rows of col B, do not cut thread but leave it to the side for the next stripe of that colour,
- Using col C work **1** row, do not cut thread but leave it to the side for the next stripe of that colour,
- Using col A work **1** row, do not cut thread but leave it to the side for the next stripe of that colour.

Then, for each of the follow stripes, use the correct colour yarn, then do not cut yarn until instructed.

- **1** row col B
- **1** row col C
- **1** row col A
- **1** row col B
- **1** row col C
- **1** row col A
- **1** row col B
- **1** row col C
- **1** row col A
- **1** row col B
- **1** row col C

- **1** row col A
- **1** row col B
- **1** row col C
- **1** row col A
- **1** row col B
- **1** row col C
- **1** row col A

- **1** row col B, cut yarn **10 cm (4 in)** from work
- **1** row col C, cut yarn **10 cm (4 in)** from work
- **10** rows col A, cut yarn **10 cm (4 in)** from work
- Using col C work **1** row
- Using col A work **1** row
- Using col B work **1** row
- **1** row col C

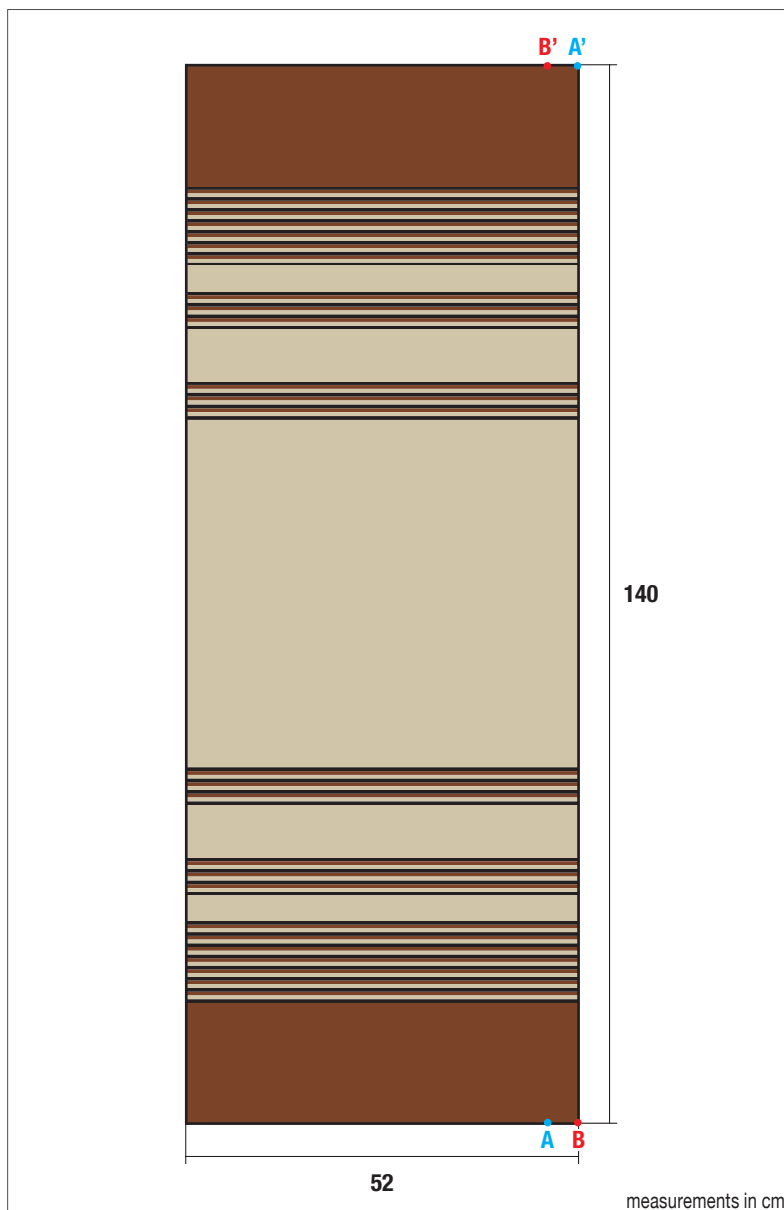

- 1 row col A
- 1 row col B
- 1 row col C
- 1 row col A
- 1 row col B, cut yarn **10 cm (4 in)** from work
- 1 row col C, cut yarn **10 cm (4 in)** from work
- **18** rows col A, cut yarn **10 cm (4 in)** from work
- Using col C work **1** row
- Using col A work **1** row
- Using col B work **1** row
- 1 row col C
- 1 row col A
- 1 row col B
- 1 row col C
- 1 row col A
- 1 row col B, cut yarn **10 cm (4 in)** from work
- 1 row col C, cut yarn **10 cm (4 in)** from work
- **110** rows col A, cut yarn **10 cm (4 in)** from work
- Using col C work **1** row
- Using col A work **1** row
- Using col B work **1** row
- 1 row col C
- 1 row col A
- 1 row col B
- 1 row col C
- 1 row col A
- 1 row col B, cut yarn **10 cm (4 in)** from work
- 1 row col C, cut yarn **10 cm (4 in)** from work
- **18** rows col A, cut yarn **10 cm (4 in)** from work
- Using col C work **1** row
- Using col A work **1** row
- Using col B work **1** row
- 1 row col C
- 1 row col A
- 1 row col B
- 1 row col C
- 1 row col A
- 1 row col B, cut yarn **10 cm (4 in)** from work
- 1 row col C, cut yarn **10 cm (4 in)** from work
- **10** rows col A, cut yarn **10 cm (4 in)** from work
- Using col C work **1** row
- Using col A work **1** row
- Using col B work **1** row
- 1 row col C
- 1 row col A
- 1 row col B
- 1 row col C
- 1 row col A
- 1 row col B
- 1 row col C
- 1 row col A

- 1 row col B
  - 1 row col C
  - 1 row col A
  - 1 row col B
  - 1 row col C
  - 1 row col A
  - 1 row col B
  - 1 row col C
  - 1 row col A, cut yarn **10 cm (4 in)** from work
  - 1 row col B, cut yarn **10 cm (4 in)** from work
  - 1 row col C, cut yarn **10 cm (4 in)** from work
  - Using col B, work **40** rows.
- Cast off all sts (see 'Beginners Notes') then cut yarn **10 cm (4 in)** from work.

**FINISHING:**

Darning in ends:

Using the wool needle darn the ends of the yarn through a few sts on the WS of work, then cut off excess yarn (see 'Beginners Notes').

**Following the diagram:**

- Fold the stole in matching point **A** to point **A'** then point **B** to point **B'**.
- Then sew buttons on through both layers.

To wear, place the button edge over one shoulder. It is shown in the photo with the buttons at the Front.

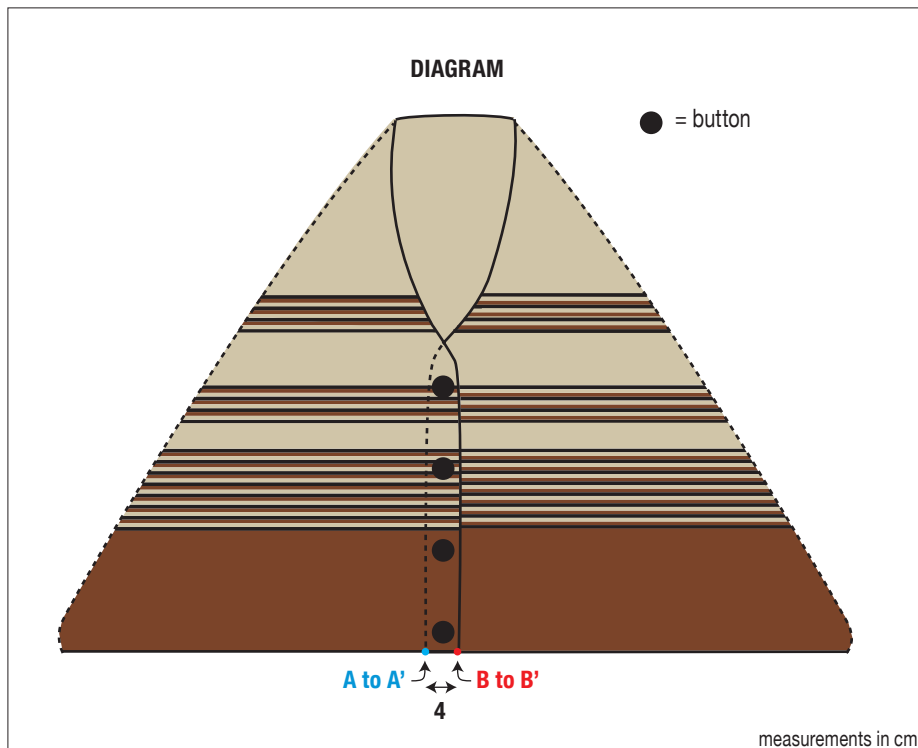

SWEATER



Quality:  
**ORILIS**

Needles:  
3.5 & 4.0 mm

Accessories:  
Stitch markers ref. 68395 (pk of 48)

Sizes		S	M	L	XL	XXL
Quality <b>ORILIS</b>		Number of balls				
Astral	20105	6	7	8	8	9

Stitches used

**STOCKING ST (St st)**, using 3.5 mm & 4.0 mm needles.

**GARTER ST (G.st)**, using 4.0 mm needles.

**LACE STITCH A**, using 4.0 mm needles. Over an even number of sts.

**Row 1 (RS):** k1, \*yfwd, k2tog\* rep from \*to\* ending with k1.

**Row 2:** knit.

Rep these 2 rows.

**LACE STITCH B**, using 4.0 mm needles. Over an even number of sts.

**Row 1 (RS):** k2, \*yfwd, k2\* rep from \*to\* ending with k2.

**Row 2 & 4:** purl.

**Row 3:** k3, \*yfwd, sl 1, k1, pss0\* rep from \*to\* ending with k1.

Rep Rows 1 to 4.

Tension/Gauge

To achieve a good result it is essential to make a tension square (see "Check Your Tension" instructions at beginning of book).

22 sts & 27 rows over Stocking st using 4.0 mm needles = 10 cm (4 in) square.

18 sts & 28 rows over Lace Stitch B using 4.0 mm needles = 10 cm (4 in) square.

To make

BACK:

Using 3.5 mm needles CO 96-104-114-124-136 sts. Starting with a knit row cont in St st for 2 cm (¾ in) [6 rows] total.

Change to 4.0 mm needles & cont as foll:

4 rows St st,

2 rows G.st,

2 rows **Lace St A**,

12-12-12-14-14 rows St st,

2 rows G.st,

2 rows **Lace St A**,

6 rows St st,

2 rows G.st,  
2 rows **Lace St A**,  
6 rows St st,  
2 rows G.st,  
2 rows **Lace St A**,  
12-12-12-14-14 rows St St,  
2 rows G.st,  
2 rows **Lace St A**,  
12 rows St st,  
2 rows G.st,  
8 rows St st,  
2 rows G.st,

Then cont in St st until work measures 34-35-35-36-37 cm (13¼-13¾-13¾-14-14½ in) [94-98-98-100-102 rows] total.

Armholes:

Slip a stitch marker into the first & last stitch of the next row to mark the beg of the armholes (see diagram) & then cont in St st.

When work measures approx. 37-38-38-39-40 cm (14½-15-15-15¼-15¾ in) [101-105-105-107-109 rows] total, work next WS row as foll:

**S:** p2, p2tog, \*p4, p2tog\* rep from \*to\* ending with p2 (= 16 dec).

**M:** p5, \*p2tog, p3, p2tog, p4\* rep from \*to\* (= 18 dec).

**L:** p4, \*p2tog, p3, p2tog, p4\* rep from \*to\* (= 20 dec).

**XL:** p4, \*p2tog, p3, p2tog, p4\* rep from \*to\* ending with p2tog, p3, p2tog, p3 (= 22 dec).

**XXL:** p4, \*p2tog, p3, p2tog, p4\* rep from \*to\* (= 24 dec).

Cont on the rem 80-86-94-102-112 sts using **Lace Stitch B** until work measures 49-51-53-55-57 cm (19¼-20-20¾-21¼-22½ in) [134-142-148-152-158 rows] total.

Neck:

**Next row (RS):** Work 29-31-34-37-41 sts, cast off the central 22-24-26-28-30 sts for the neck, work to end.

**Next row (WS):** Work to cast off sts, put rem sts on a spare needle. Work will now be completed in 2 sections.

\*Cont to cast off at neck edge on every alt row as foll: 3 sts once, 2 sts once.

Cont on the rem 24-26-29-32-36 sts until work measures 51-53-55-57-59 cm (20-20¾-21¼-22½-23¼ in) [140-148-154-158-164 rows] total.

Shoulders:

Cast off all sts.\*

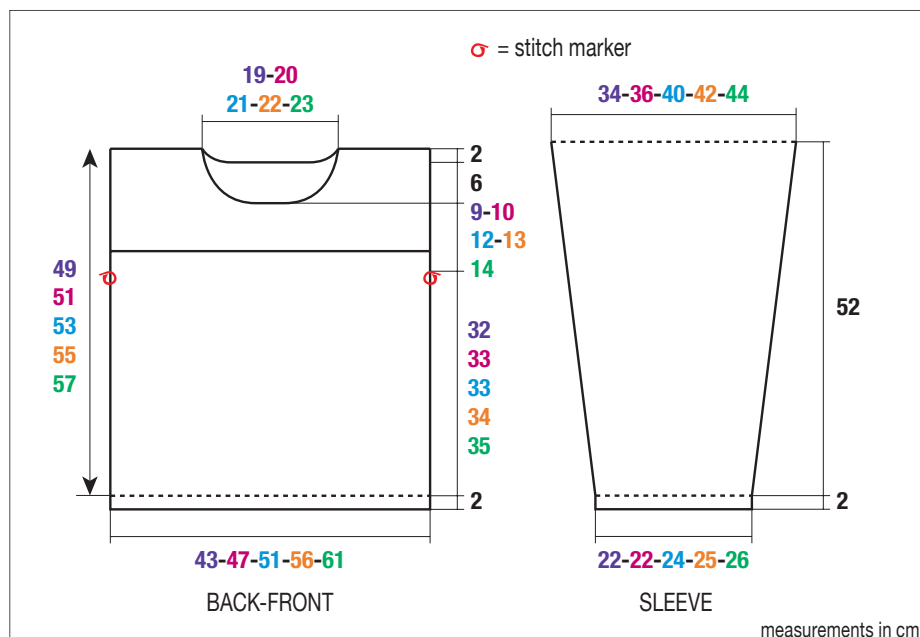



# PONCHO



Quality:  
**ORILIS**



Crochet hook size:  
**3.5 mm**

**One size**

Quality <b>ORILIS</b>		Number of balls
Sable	20108	11

## ● Abbreviations

**Chain St** = Ch

**Single Crochet (UK: Double Crochet)** = sc (uk: dc)

**Half Double Crochet (UK: Half Treble)** = hdc (uk: half tr)

**Double Crochet (UK: Treble)** = dc (uk: tr)

**Treble (UK: Double Treble)** = tr (uk: dbl tr)

**3 Treble Crochets Together (UK: 3 Double Trebles Together)** = 3 tr tog (uk: 3 dbl tr tog):

\*yo twice, put hook into next st, yo, draw loop through, yo, pass through 2 loops on hook\* rep from \*to\* twice more, then yo, pass through the 4 loops on hook.

**15 Treble Crochets Together (UK: 15 Double Trebles Together)** = 15 tr tog (uk: 15 dbl tr tog):

\*yo twice, put hook into next st, yo, draw loop through, yo, pass through 2 loops on hook\* rep from \*to\* 14 more times, then yo, pass through the 16 loops on hook.

## ● Stitches used

**PATTERN ST**, using 3.5 mm hook. Over a number of sts divisible by 48 + 1 for the chain + 4 for the beg of the 1st row (these 4 sts replace the 1st tr (uk: dbl tr)).

**Row 1 (RS):** 7 tr (uk: dbl tr) into the 5th ch, • \*skip 7 ch, 3 tr (uk: dbl tr) into the foll st\* rep from \*to\* 4 more times, skip 7 ch, 15 tr (uk: dbl tr) into the foll st • rep from •to• ending with 8 tr (uk: dbl tr) into the last ch instead of 15.

**Row 2:** 2 ch (replaces the 1st hdc (uk: half tr)), 1 hdc (uk: half tr) into the 2nd tr (uk: dbl tr) then every foll tr (uk: dbl tr).

**Row 3:** 2 ch (replaces the 1st hdc (uk: half tr)), 1 hdc (uk: half tr) into the 2nd hdc (uk: half tr) then every foll hdc (uk: half tr).

**Row 4:** 12 ch, skip the first 2 hdc (uk: half tr), 3 tr tog (uk: 3 dbl tr tog), 7 ch, 3 tr tog (uk: 3 dbl tr tog), 7 ch, 15 tr tog (uk: 15 dbl tr tog), 7 ch, • \*3 tr tog (uk: 3 dbl tr tog), 7 ch\* rep from \*to\* 4 more times,

then 15 tr tog (uk: 15 dbl tr tog), 7 ch • rep from •to• ending with 3 tr tog (uk: 3 dbl tr tog), 7 ch, 3 tr tog (uk: 3 dbl tr tog), 7 ch, 1 tr (uk: dbl tr) into the last st.

**Row 5:** 6 ch, 1 sc (uk: dc) into the 1st loop, 7 ch, \*1 sc (uk: dc) into the foll loop, 7 ch\* rep from \*to\* **but** in the last loop work 1 sc (uk: dc), 3 ch, then 1 dc (uk: tr) into the 6th ch at beg of preceding row.

**Row 6:** 10 ch, skip the 1st loop, \*1 sc (uk: dc) into the foll loop, 7 ch\* rep from \*to\* **but** in the last loop work 1 dc (uk: tr) into the 3rd ch at beg of the preceding row.

**Row 7:** 6 ch, 1 sc (uk: dc) into the 1st loop, 7 ch, \*1 sc (uk: dc) into the foll loop, 7 ch\* rep from \*to\* **but** in the last loop work 1 sc (uk: dc), 3 ch, then 1 dc (uk: tr) into the 3rd ch at the beg of the preceding row.

**Row 8:** 4 ch, 7 tr (uk: dbl tr) into the dc (uk: tr), skip the 1st loop, then work \*3 tr (uk: dbl tr) into the 4th ch of each of the foll 5 loops, then 15 tr (uk: dbl tr) into the 4th ch of each loop\* rep from \*to\* ending with 8 tr (uk: dbl tr) into the 3rd ch of the last loop of 15.

Rep from Row 2.

**Crochet Terms:** See 'Crochet: Stitches/Techniques'

## ● Tension/Gauge

To achieve a good result it is essential to make a tension square (see "Check Your Tension" instructions at beginning of book).

1 motif = 14.5 cm (5¾ in) width

7 rows = 12.5 cm (5 in) height.

## ● To make

### BACK:

Make a chain of **341** sts. Work in Pattern St (= 7 motifs).

When work measures approx. **75** cm (**29½** in) [**42** rows] total, after a 7th row of Pattern St, fasten off.

### FRONT:

Work as for Back.

### FINISHING:

Join the top of the Back & Front leave the central **7** loops open **for the neck**.

Secure & weave in all ends.

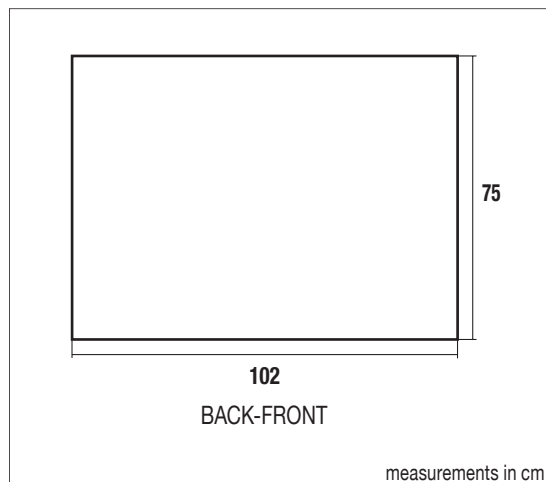

**PATTERN ST**

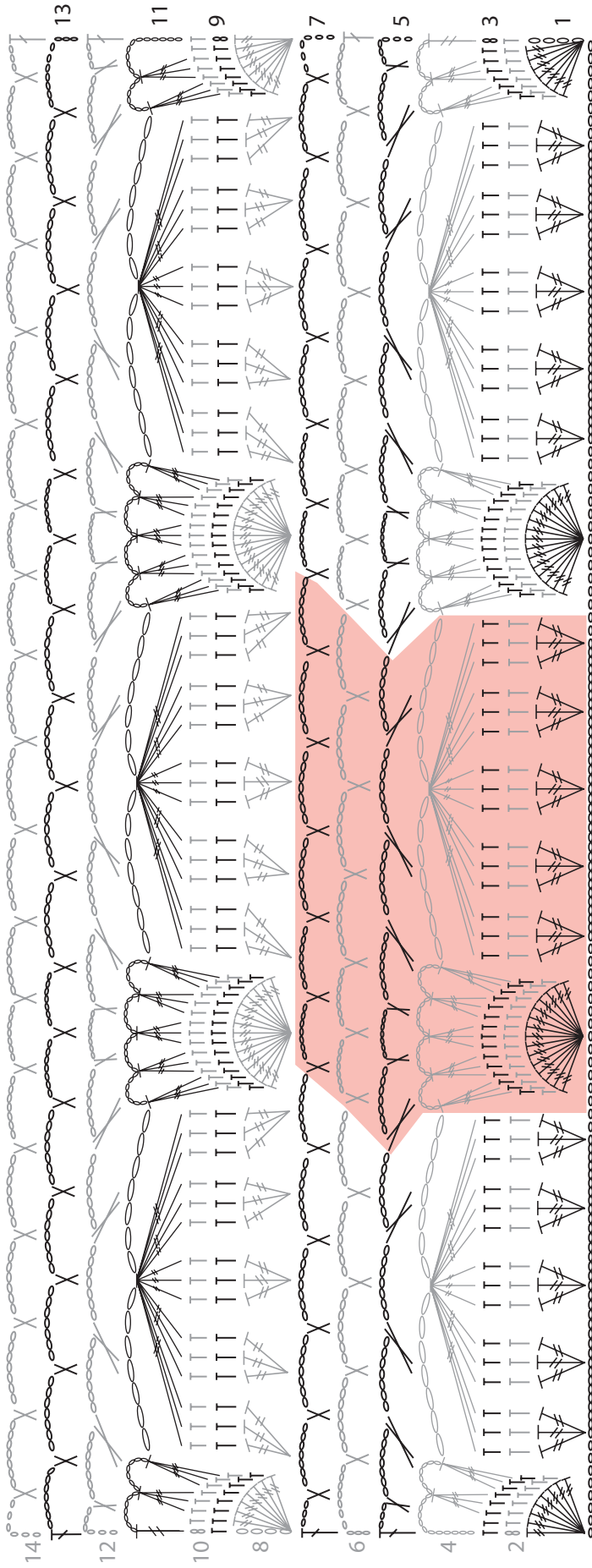

- or ○ = 1 Ch
- ⌋ or ⌋ = 1 tr (uk: dbl tr)
- ┆ or ┆ = 1 hdc (uk: half tr)
- ┆ or ┆ = 1 dc (uk: tr)
- X or X = 1 sc (uk: dc)

- ⌋ or ⌋ = 3 tr tog (uk: 3 dbl tr tog)
- ┆ or ┆ = 15 tr tog (uk: 3 dbl tr tog)

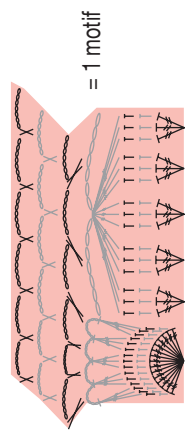

# CROSS OVER



Quality:  
**ORILIS**

Needles:  
4.0 mm



Accessories:

90 cm red grosgrain ribbon 10 mm ref. 30926 (sold in 1 metre lengths)  
4 transparent press studs 13 mm ref. 60467 (pk of 59 assorted)

Sizes		S	M	L	XL	XXL
Quality <b>ORILIS</b>		Number of balls				
Bordeaux	20102	6	6	7	7	8

## Stitches used

**GARTER STITCH (G.st)**, using 4.0 mm needles.

**LACE STITCH**, using 4.0 mm needles. Over a number of sts divisible by 8 + 1. Follow the Chart.

**STOCKING STITCH (St st)**, using 4.0 mm needles.

## Tension/Gauge

To achieve a good result it is essential to make a tension square (see "Check Your Tension" instructions at beginning of book).

22 sts & 27 rows over Lace St using 4.0 mm needles = 10 cm (4 in) square.

## To make

### BACK:

Using 4.0 mm needles CO 97-105-113-125-137 sts. Work 2 rows in G.st.

Cont as foll:

#### Note:

- 1 yo should always be compensated with sl1, k1, pssso or k2tog.
- 2 yo should always be compensated with sl1, k2tog, pssso.

**Row 1 (RS):** k0-0-0-2-0, work in Lace st starting at st 1-5-1-1-1 on the Chart until 0-0-0-2-0 sts rem, k0-0-0-2-0.

**Row 2:** p0-0-0-2-0, work in Lace st until 0-0-0-2-0 sts rem, p0-0-0-2-0.

These 2 rows set the patt, cont until work measures 36-37-37-38-39 cm (14-14½-14½-15-15¼ in) [98-100-100-102-106 rows] total.

### Armholes:

Cast off 5-5-6-7-10 sts at beg of next 2 rows, then cont as foll:

**Next row (RS – dec):** k1, sl1, k1, pssso, patt until 3 sts rem on LH needle, k2tog, k1.

Rep this dec row on every RS row 5-6-6-9-10 more times.

Cont in Lace st on the rem 75-81-87-91-95 sts until work measures 51-53-55-57-59 cm (20-20¼-21½-22½-23 in) [138-142-148-154-160 rows] total.

### Neck:

**Next row (RS):** Patt 26-28-30-31-32, cast off the central 23-25-27-29-31 sts, patt to end.

**Next row (WS):** Patt to central cast off sts. Put rem sts on a stitch holder. Work will now be completed in 2 sections.

\*Cast off at neck edge on next & foll alt row: 3 sts once, 2 sts once.

### Shoulders:

When work measures 53-55-57-59-61 cm (20¼-21½-22½-23-24 in) [144-148-154-160-166 rows] total leave the rem 21-23-25-26-27 sts on a spare needle\*.

With WS facing pick up sts left on stitch holder & rep from \*to\* above.

### LEFT FRONT:

**Note:** There will not be a border later so avoid changing balls at neck edge.

Using 4.0 mm needles CO 66-70-74-84-90 sts. Work 2 rows in G.st.

**Row 1 (RS):** k0-0-0-2-0, starting at st 1-5-1-1-1 on the Chart work 65-69-73-81-89 sts in Lace st from the Chart, k1.

**Row 2:** p1, work 65-69-73-81-89 sts in Lace st from the Chart, p0-0-0-2-0.

These 2 rows set the patt, cont until work measures 27 cm (10½ in) [74 rows] total.

### Neck & Armholes:

\***Next row (neck edge – 1 st dec):** Patt until 3 sts rem on LH needle, k2tog, k1. Work 1 row straight. Rep this 1 st dec 1 more time. Work 1 row straight.

**Next row (neck edge – 2 st dec):** Patt until 4 sts rem on LH needle, k3tog, k1. Work 1 row straight\*.

Rep from \* to \* 7-7-7-8-9 more times, then work the 1 st dec on every RS row 2-3-4-5-2 more times.

**At the same time**, when work measures 36-37-37-38-39 cm (14-14½-14½-15-15¼ in) [98-100-100-102-106 rows] total, cast off & dec at the beg of every RS row for the armholes in the same way as for Back.

After the final neck dec cont on the rem 21-23-25-26-27 sts.

### Shoulder:

When work measures 53-55-57-59-61 cm (20¼-21½-22½-23-24 in) [144-148-154-160-166 rows] total leave the rem sts on a spare needle.

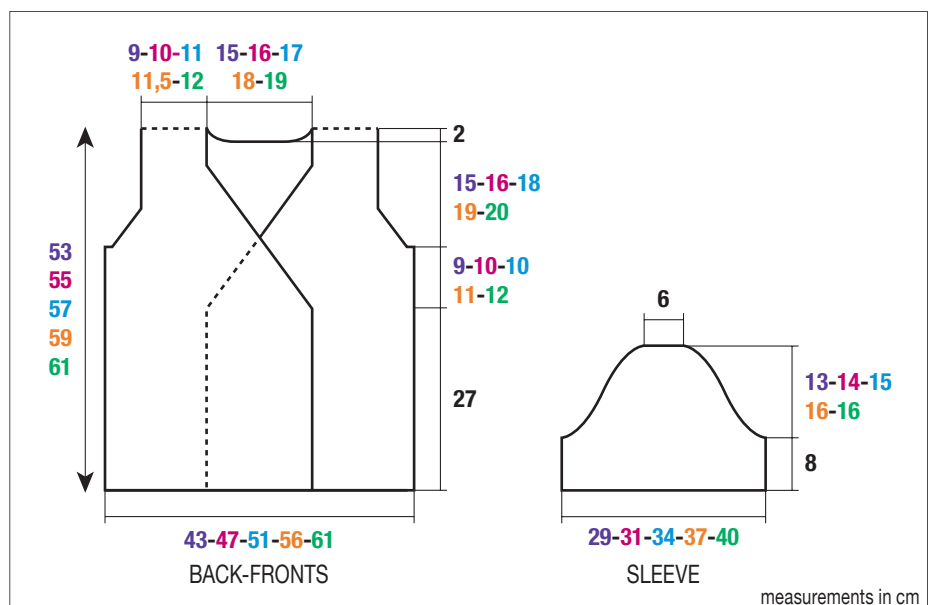

## RIGHT FRONT:

Using 4.0 mm needles CO **66-70-74-84-90** sts.  
Work 2 rows in G.st.

**Row 1 (RS):** k1, starting at st 1 on the Chart work **65-69-73-81-89** sts in Lace st from the Chart, **k0-0-0-2-0**

**Row 2:** **p0-0-0-2-0**, work **65-69-73-81-89** sts in Lace st from the Chart, p1.

These 2 rows set the patt, cont until work measures **27 cm (10½ in) [74 rows]** total.

### Neck & Armholes:

**\*Next row (neck edge – 1 st dec):** k1, sl1, k1, pssso, patt to end. Work 1 row straight.

Rep 1 st dec 1 more time. Work 1 row straight.

**Next row (neck edge – 2 st dec):** sl1, k2tog, pssso, patt to end. Work 1 row straight\*.

Rep from \* to \* **7-7-7-8-9** more times, then work the 1 st dec on every RS row **2-3-4-5-2** more times.

**At the same time**, when work measures **36-37-37-38-39** cm (**14-14½-14½-15-15¼** in) [**98-100-100-102-106** rows] total, cast off **5-5-6-7-10** sts at the beg of next WS row, then cont to dec at the end of every RS row for the armholes in the same way as for Back.

After the final neck dec cont on the rem **21-23-25-26-27** sts.

## Shoulder:

When work measures **53-55-57-59-61** cm (**20¾-21½-22½-23-24** in) [**144-148-154-160-166** rows] total leave the rem sts on a spare needle.

## SLEEVES:

Using 4.0 mm needles CO **65-69-77-83-89** sts.  
Work 2 rows in G.st.

Cont as foll:

**Row 1 (RS):** **k0-2-2-1-0**, work in Lace st until **0-2-2-1-0**, sts rem, **k0-2-2-1-0**.

**Row 2:** **p0-2-2-1-0**, work in Lace st until **0-2-2-1-0** sts rem, **p0-2-2-1-0**.

These 2 rows set the patt, cont until work measures **8 cm (3 in) [22 rows]** total.

### Top of sleeve:

Cast off: 3 sts at beg of next **2-2-2-4-4** rows, 2 sts at beg of next **2-4-6-4-6** rows, 1 st at beg of next **26-26-24-28-24** rows, 2 sts at beg of next **4-4-4-4-6** rows, 3 sts at beg of next **2-2-4-4-2** rows, **0-0-0-0-4** sts at beg of next 2 rows. Cast off rem 15 sts.

## FINISHING:

Join the shoulders using chain st on the WS of work (see “Knitting: Stitches/Techniques/Tips”).

Sew the tops of the sleeves into the armholes.

Sew the sleeve & side seams.

Ribbon: Cut the ribbon into 4 equal lengths. Fold over 1 cm at one end of each length of ribbon.

Following the diagram:

① Sew the folded end of 2 lengths of ribbon onto the WS of the Right Front.

② Sew the folded end of the rem 2 lengths of ribbon onto the WS of the Left Front. Then, pull the ribbons through to the RS.

③ Sew the concave part of the press studs on the WS of the Right Front.

④ Sew the convex part of the press studs on the RS on the Left Front.

Secure & weave in all ends.

## LACE STITCH

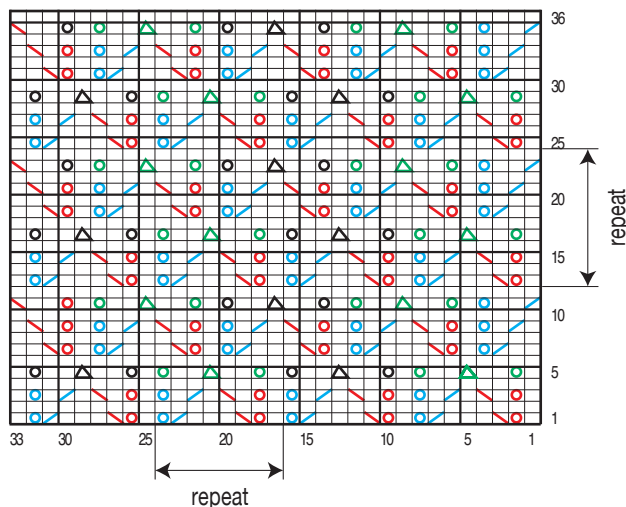

- = K1 on RS, P1 on WS
- ◻ or ◻ or ◻ or ◻ = 1 yo
- ◻ = sl1, k1, pssso
- ◻ = k2tog
- ◻ or ◻ = sl1, k2tog, pssso

DIAGRAM

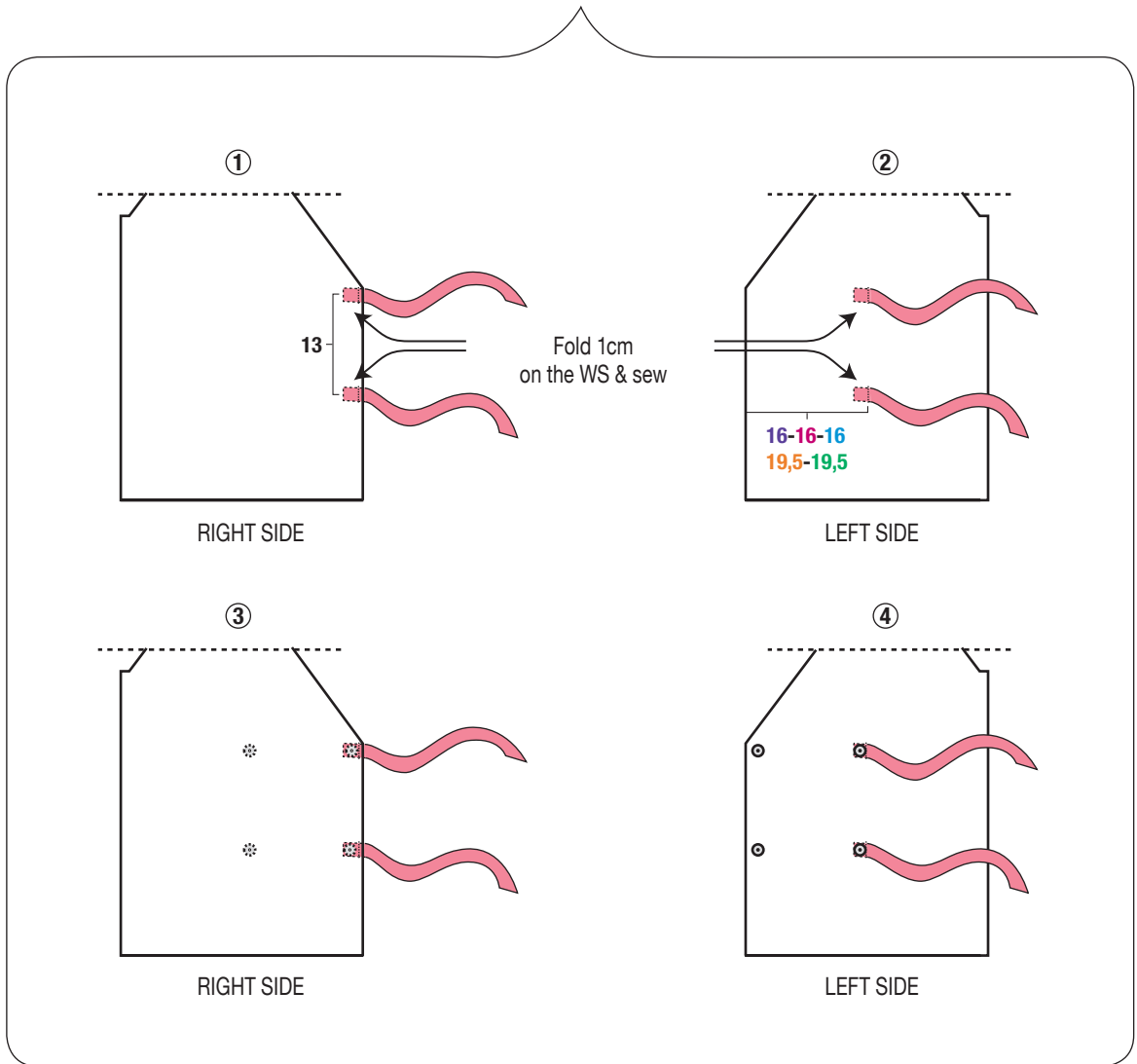
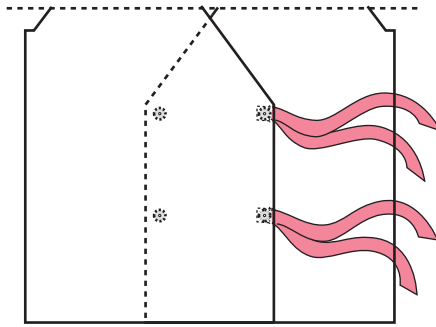

= ribbon  
 ✱ = concave part of the press studs on the WS of Right Front  
 ○ = convex part of the press studs on the RS of Left Front

# CARDIGAN



Quality:  
**ORILIS**

Needles:  
**6.0 mm**



Accessories:

**Stitch markers ref. 68395 (pk of 48)**

**3 pink printed 'heart' buttons Ø 12 mm ref. 67871 (pk of 6)**

Sizes		1 mths	3 mths	6 mths	12 mths
Quality <b>ORILIS</b>		Number of balls			
Malabar	20109	3	3	4	4

## Stitches used

The cardigan is made using 2 strands of yarn held together throughout.

**GARTER STITCH (G.ST)**, using 6.0 mm needles. Knit every row.

## Tension/Gauge

To achieve a good result it is essential to make a tension square (see "Check Your Tension" instructions at beginning of book).

14 sts & 26 rows over G.st using 6.0 mm needles & 2 strands of yarn held together = 10 cm (4 in) square.

## To make

### BACK:

Using 6.0 mm needles & 2 strands of yarn held together cast on **30-33-36-38** sts.

Work in G.st (knit every row).

### Armholes:

When work measures **14-15-17-19** cm (**5½-5¾-6½-7½** in) [**38-40-44-50** rows] total, slip a stitch marker into the first and last st to mark the start of the armholes (see diagram) and continue in G.st until work measures **22-24-27-30** cm (**8½-9¼-10½-11¼** in) [**58-62-70-78** rows] total.

### Neck & shoulders:

**Next row (RS):** **k9-10-11-12**, cast off the following **12-13-14-14** sts for the neck, knit to end.

Leave the rem **9-10-11-12** sts each side of neck on a spare needle **for the shoulders**.

### LEFT FRONT:

Using 6.0 mm needles & 2 strands of yarn held together cast on **17-19-20-21** sts.

Work in G.st (knit every row).

### Armhole:

When work measures **14-15-17-19** cm (**5½-5¾-6½-7½** in) [**38-40-44-50** rows] total, slip a stitch marker into the first st to mark the start of the armholes and continue in G.st until work measures **18-20-23-26** cm (**7-8-9-10** in) [**48-52-60-68** rows] total.

### Neck:

Work 1 row straight.

Cast off **4-5-5-5** sts at beg of next WS row, knit to end.

**Next row (RS – 2 st dec):** knit until there are 5 sts remaining on the LH needle, sl1, k2tog, pssso, k2. Knit one row.

**Next row row (RS – 1 st dec):** knit until there are 4 sts remaining on the LH needle, sl1, k1, pssso, k2. Repeat the 1 st decrease 1 more time.

### Shoulder:

When work measures **22-24-27-30** cm (**8½-9¼-10½-11¼** in) [**58-62-70-78** rows] total. Leave the rem **9-10-11-12** sts on a spare needle for the shoulder.

### RIGHT FRONT:

Using 6.0 mm needles & 2 strands of yarn held together cast on **17-19-20-21** sts.

Work in G.st (knit every row).

### Armhole:

When work measures **14-15-17-19** cm (**5½-5¾-6½-7½** in) [**38-40-44-50** rows] total, slip a stitch marker into the LAST st to mark the start of the armholes and continue in G.st until work measures **18-20-23-26** cm (**7-8-9-10** in) [**48-52-60-68** rows] total.

### Neck:

Cast off **4-5-5-5** sts at beg of next RS row, knit to end. Work 1 row straight.

**Next row (RS – 2 st dec):** k2, k3tog, knit to end of row. Knit one row.

**Next row row (RS – 1 st dec):** k2, k2tog, knit to end of row.

Repeat the 1 st decrease 1 more time.

### Shoulder:

When work measures **22-24-27-30** cm (**8½-9¼-10½-11¼** in) [**58-62-70-78** rows] total.

Leave the rem **9-10-11-12** sts on a spare needle for the shoulder.

### SLEEVES:

Using 6.0 mm needles & 2 strands of yarn held together cast on **22-23-24-25** sts.

Work in G.st for **10-14-12-12** rows then continue as follows:

**Next row (RS – inc):** k2, inc 1, knit to last 2 sts, inc 1, k2.

Repeat this increase row on following **0-14th-12th-12th** row **0-1-2-3** more times.

Continue in G.st on the **24-27-30-33** sts obtained.

### Top of sleeve:

When work measures **15-17-19-22** cm (**6-6½-7¼-8½** in) [**40-44-50-58** rows] total, leave the sts on a spare needle.

### FINISHING:

Join the shoulders using chain st on the WS of work (see "Knitting: Stitches/Techniques/Tips").

Graft the tops of the sleeves into the armholes using back stitch, placing them either side of the shoulder seam and between the stitch markers. (See "Knitting: Stitches/Techniques/Tips").

Sew the sleeve & side seams of the cardigan.

Sew the buttons down the Left Front 1 cm in from the edge: placing the 1st 1 cm down from the neck, the others spaced at **4-5-6-7** cm (**1½-2-2¼-2¾** in) intervals.

To wear, slip the buttons between the sts on the Right Front.

Secure & weave in all ends.

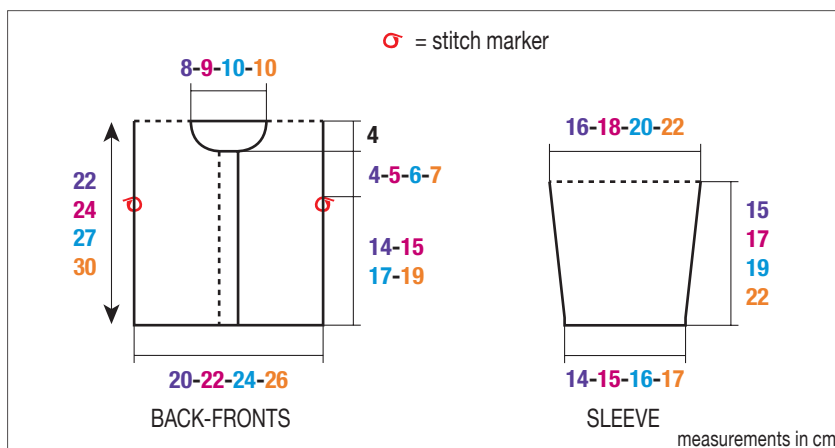

# CROSS OVER



Quality: **ORILIS**



Crochet hook size: **4.0 mm**



Accessories:

**Stitch markers ref. 68395 (pk of 48)**

**1 metre of pink reversible woven ribbon ref. 67859 (sold in 1 metre lengths)**

Sizes		4 yrs	6 yrs	8 yrs	10 yrs
Quality <b>ORILIS</b>		Number of balls			
Fraise	20121	4	4	5	6

## ● Abbreviations

**Chain st** = ch st

**Double crochet (UK: Treble crochet)** = dc (UK: tr)

**2 dc together (UK: 2 tr together)** = 2 dc tog (UK: 2 tr tog): See 'Crochet: Stitches/Techniques'.

## ● Stitches used

**DOUBLE CROCHET (UK: treble crochet) PATTERN**, using 4.0 mm crochet hook.

**Row 1 (RS):** 1 dc (UK: tr) into the 4th ch (= the first 2 dc (UK: tr)), 1 dc (UK: tr) into every foll ch.

**Row 2 & every foll row:** 3 ch (replaces the 1st dc (UK: tr)), 1 dc (UK: tr) in the 2nd dc (UK: tr), then 1 dc (UK: tr) in every foll dc (UK: tr).

### DC (UK: TR)

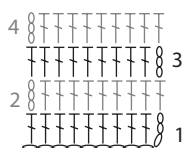

○ or ○ = 1 ch

⌋ or ⌋ = 1 dc (UK: tr)

**Crochet basics:** See 'Crochet: Stitches/Techniques'.

## ● Tension/Gauge

To achieve a good result it is essential to make a tension square (see "Check Your Tension" instructions at beginning of book).

19 dc (UK: tr) & 11.5 rows over dc (UK: tr) using 4.0 mm crochet hook = 10 cm (4 in) square.

## ● To make

### BACK:

Using 4.0 mm hook make a chain of **53-59-64-70** sts. Work in dc (UK: tr) pattern (= **51-57-62-68** dc (UK: tr)) until work measures **20-22-24-26** cm (**7¾-8½-9½-10¼** in) [**23-25-27-30** rows] total.

### Armholes:

Slip a stitch marker into the 1st & last st to mark the start of the armholes (see diagram) & cont in dc (UK: tr).

### Shoulders & neck:

When work measures **31-34-37-40** cm (**12-13¼-14½-15¾** in) [**36-39-42-46** rows] total, fasten off.

### RIGHT FRONT:

Using 4.0 mm hook make a chain of **52-58-63-69** sts. Work in dc (UK: tr) pattern (= **50-56-61-67** dc (UK: tr)).

Middle Front angle & armholes:

### For the angle:

Work 1 row straight.

**Next row (WS – dec):** Work to the end of the row until there are 4 dc (UK: tr) rem work 2 dc tog (UK: 2 tr tog).

**Next row (RS – dec):** 3 ch (replaces the 1st dc (UK: tr)) 1 dc (UK: tr) in the 2nd dc (UK: tr), 2 dc tog (UK: 2 tr tog), work to end of row.

Cont to work these dec on every row **31-35-38-42** times.

**At the same time**, when work measures **20-22-24-26** cm (**7¾-8½-9½-10¼** in) [**23-25-27-30** rows] total, at the opposite edge to the front angle slip a stitch marker into the first st **to mark the start of the armhole.**

After the final dec for the angle, cont on the rem **17-19-21-23** sts.

### Shoulder:

When work measures **31-34-37-40** cm (**12-13¼-14½-15¾** in) [**36-39-42-46** rows] total, fasten off.

### LEFT FRONT:

Using 4.0 mm hook make a chain of **52-58-63-69** sts. Work in dc (UK: tr) (= **50-56-61-67** dc (UK: tr)).

### Middle Front angle & armholes:

#### For the angle:

Work 1 row straight.

**Next row (WS – dec):** 3 ch (replaces the 1st dc (UK: tr)) 1 dc (UK: tr) in the 2nd dc (UK: tr), 2 dc tog (UK: 2 tr tog), work to end of row.

**Next row (RS – dec):** Work to the end of the row until there are 4 dc (UK: tr) rem work 2 dc tog (UK: 2 tr tog).

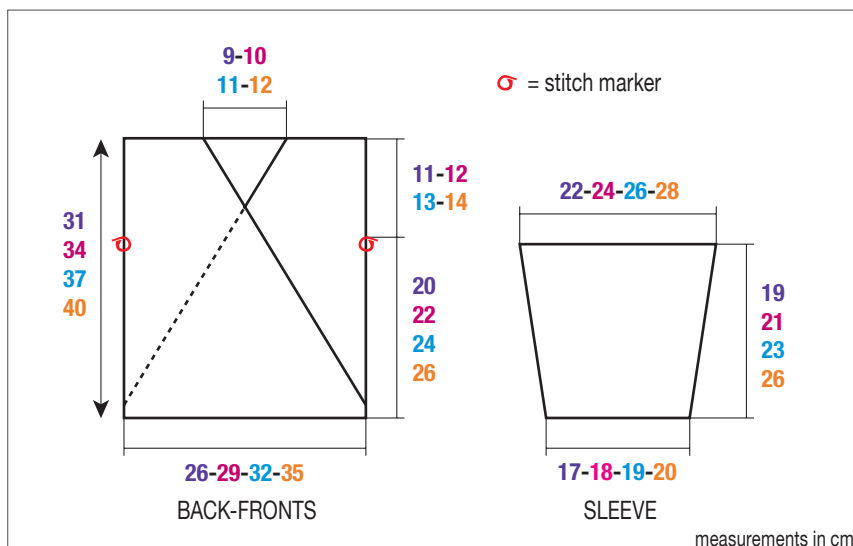



# T SWEATER



Quality: **ORILIS**

Crochet hook size: **4.0 mm**

Sizes		4 yrs	6 yrs	8 yrs	10 yrs	12 yrs
Quality <b>ORILIS</b>		Number of balls				
Ananas	20104	3	4	5	5	6

### Start of sleeves:

Foll diagram no. 1 inc 12 sts at each edge.

Cont in Pattern st on the **86-92-98-104-110** sts obtained, until work measures **28-32-36-40-44** cm (**11-12½-14-15¼-17¼** in) [**20-24-28-30-34** rows] total.

### Neck:

The work will now be separated into 2 pieces leaving the central **8-8-14-14-14** sts unworked.

#### 1st part:

Cont on the first **39-42-42-45-48** sts dec & inc at the neck edge foll **diagram no. 2**. After you have worked the chain of **20-20-26-26-26** sts, fasten off.

#### 2nd part:

Cont on the last **39-42-42-45-48** sts dec & inc at the neck edge foll **diagram no. 2**. **But at the same time** as the inc, close the neck as foll: 4 ch, 1 sl st in the last st of the ch, then cont along the row.

Cont in Pattern st on the **86-92-98-104-110** sts obtained.

### PATTERN STITCH

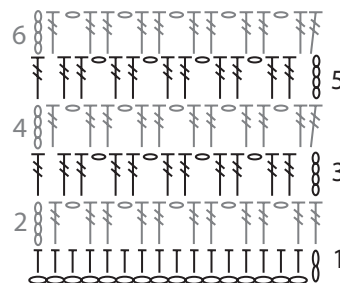

○ or ○ = 1 ch  
 † = 1 hdc (UK: hlf tr)  
 † or † = 1 tr (UK: dbl tr)

## ● Abbreviations

Chain st = ch st

Slip st = sl st

Half double crochet (UK: half treble) = hdc (UK: hlf tr)

Treble (UK: Double treble) = tr (UK: dbl tr)

2 trebles together (UK: 2 Double trebles together) = 2 tr tog (UK: 2 dbl tr tog): See 'Crochet: Stitches/Techniques'.

## ● Stitches used

**PATTERN STITCH**, using 4.0 mm crochet hook. Over a number of sts divisible by 3 + 2 for the chain + 1 for the start of the 1st row.

**Row 1 (RS):** 1 hdc (UK: hlf tr) into the 3rd ch (= the first 2 hdc (UK: hlf tr)), 1 hdc (UK: hlf tr) in every foll ch.

**Row 2:** 4 ch, 1 tr (UK: dbl tr) in the 2nd hdc (UK: hlf tr), \*1 ch, skip 1 hdc (UK: hlf tr), 1 tr (UK: dbl tr) in each of the foll 2 hdc (UK: hlf tr)\*, rep from \* to \*.

**Row 3:** 4 ch, 2 tr (UK: dbl tr) into the 1st ch space of 1 ch, \*1 ch, 2 tr (UK: dbl tr) in the foll ch space\*, rep from \* to \*, ending with 1 tr (UK: dbl tr) in the 4th ch on the previous row.

Rep Rows 3 & 4.

**Crochet basics:** See 'Crochet: Stitches/Techniques'.

## ● Tension/Gauge

To achieve a good result it is essential to make a tension square (see "Check Your Tension" instructions at beginning of book).

19 sts & 7.5 rows over Pattern st using 4.0 mm crochet hook = 10 cm (4 in) square.

## ● To make

Made in one piece starting at the Front.

Using 4.0 mm hook make a chain of **63-69-75-81-87** sts. Work in Pattern st (1st row = **62-68-74-80-86** hdc (UK: hlf tr)) until work measures **21-25-27-31-33** cm (**8¼-9¼-10½-12-13** in) [**15-19-21-23-25** rows] total.

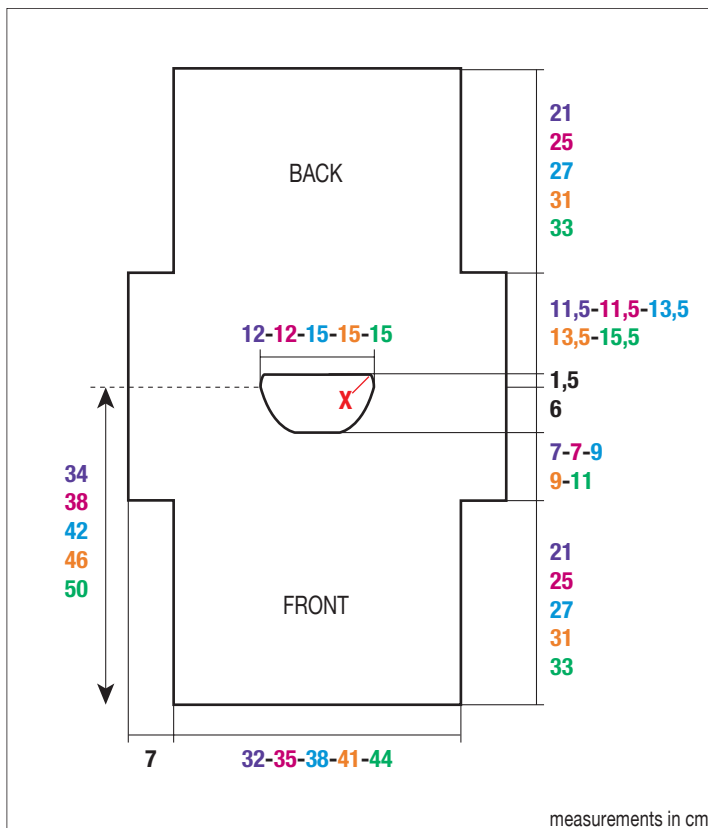

**End of sleeves:**

When work measures **47-51-57-61-67** cm (**18½-20-22¼-24-26¼** in) [**35-39-45-47-53** rows] total, leave 12 sts unworked at each edge.

Cont on the rem **62-68-74-80-86** sts until work measures **67-75-83-91-99** cm (**26¼-29½-32½-35¼-39** in) [**49-57-65-69-77** rows] total, work 2 ch, 1 hdc (UK: hlf tr) in the 2nd st, then 1 hdc (UK: hlf tr) in every foll st & fasten off.

**FINISHING:**

**Neck border:**

Starting at point **X** (see diagram), work 1 round as foll:

1 sl st, 2 ch (= 1 hdc (UK: hlf tr)), then 1 hdc (UK: hlf tr) in every st or 3 hdc (UK: hlf tr) along the stem of each tr (UK: dbl tr). Close the round with 1 sl st in the 2nd ch at the start of the round.

**Sleeve borders:**

Work 1 row as foll:

1 sl st in 1 st, 2 ch (= 1 hdc (UK: hlf tr)), then 3 hdc (UK: hlf tr) along the stem of each tr (UK: dbl tr), ending the row with 1 hdc (UK: hlf tr) in the final st.

Sew the sleeve & side seams.

Secure & weave in all ends.

**DIAGRAM NO. 2**

**FRONT & BACK NECK**

**Size 4 years & 6 years**

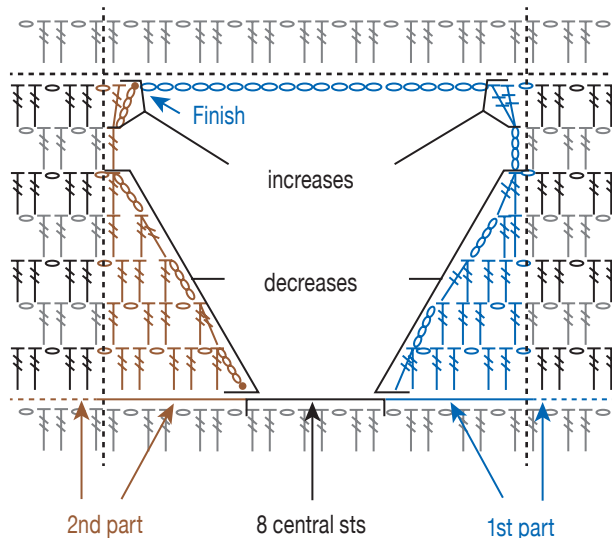

**FRONT & BACK NECK**

**Size 8 years - 10 years & 12 years**

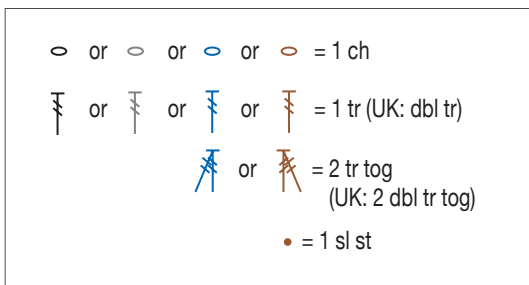
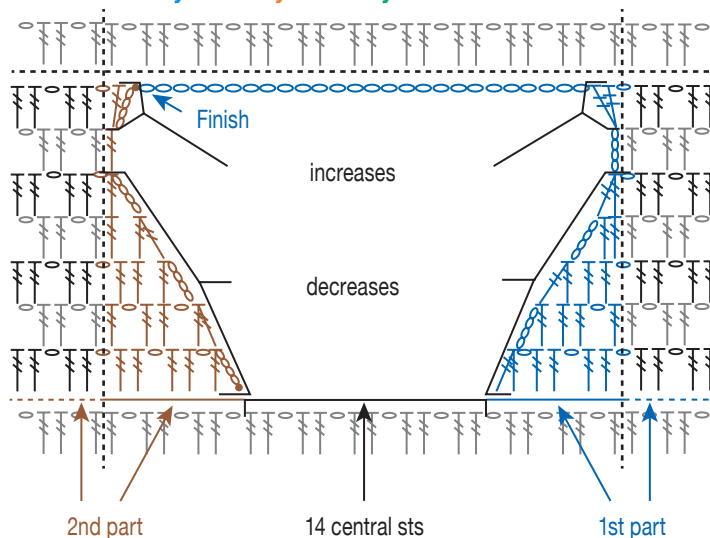

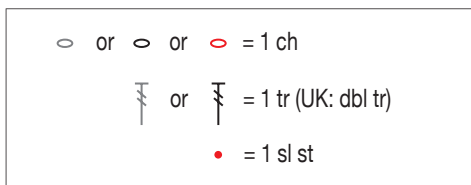
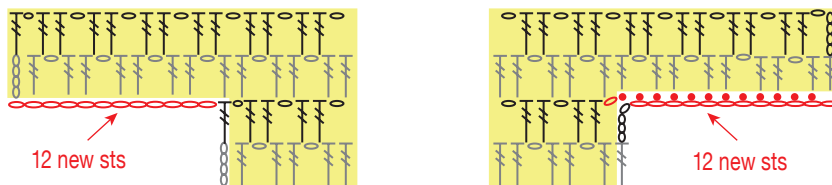

**DIAGRAM NO. 1  
START OF SLEEVES**



# SHORTS & SWEATER



-  Quality: **ORILIS**
-  Needles: **4.0 mm**
-  Accessories:  
**Sweater:**  
1 transparent press stud  
10 mm ref. 60467  
(pk of 59 assorted)
- Shorts:**  
White elastic ribbon ref. 65635 (sold in 1.75 metre lengths)

Sizes	3 mths	6 mths	12 mths	18 mths	
Quality <b>ORILIS</b>		Number of balls			
<b>Sweater:</b>					
Pistache (A) 20103	1	2	2	2	
Tourmaline (B) 20112	1	2	2	2	
<b>Shorts:</b>					
Tourmaline (B) 20112	2	2	2	2	

## Stitches used

**MOSS ST**, using 4.0 mm needles.

**Stripes:** Work 2 rows col B, 2 rows col A.

Rep these 4 rows.

**STOCKING STITCH (St st)**, using 4.0 mm needles.

## Tension/Gauge

To achieve a good result it is essential to make a tension square (see "Check Your Tension" instructions at beginning of book).

21 sts & 40 rows over Moss St using 4.0 mm needles = 10 cm (4 in) square.

22 sts & 27 rows over St st using 4.0 mm needles = 10 cm (4 in) square.

## To make

### SWEATER

#### FRONT:

Using 4.0 mm needles & col B cast on **51-55-59-63** sts. Continue in Moss st stripes as follows:

**Row 1 (RS):** Using col B \*k1, p1\*, rep from \* to \*, ending with k1.

This row forms Moss st, repeat throughout working the Stripe pattern at the same time.

#### Sleeves:

When work measures **14-16-18-19** cm (**5½-6¼-7-7½** in) [**56-64-72-76** rows] total, cast on **3-3-3-4** new sts at beginning of next 2 rows.

Continue on the **57-61-65-71** sts obtained until work measures **20-23-26-28** cm (**8-9-10-11** in) [**80-92-104-112** rows] total.

#### Neck:

**Next row (RS):** Pattern **24-25-27-29** sts, cast off the central **9-11-11-13** sts, pattern to end.

**Next row (WS):** Pattern to central cast off sts. Put remaining sts on a stitch holder. Work will now be completed in 2 sections.

**Next row (RS - dec):** Work 2 sts Moss st, k3tog, pattern to end.

Rep the dec row on every following 4th row 2 more times.

#### Shoulder:

When work measures **24-27-30-32** cm (**9¼-10½-11¼-12½** in) [**96-108-120-128** rows] total leave the remaining **18-19-21-23** sts on a spare needle.

With WS facing pick up sts left on stitch holder & work as follows:

Work 1 row in Moss st.

**Next row (RS - dec):** Work in Moss st until 5 sts remain on LH needle, sl1, k2tog, pssso, work 2 sts Moss st.

Rep the dec row on every following 4th row 2 more times.

#### Shoulder:

When work measures **24-27-30-32** cm (**9¼-10½-11¼-12½** in) [**96-108-120-128** rows] total leave the remaining **18-19-21-23** sts on a spare needle.

#### BACK:

Using 4.0 mm needles & col B cast on **51-55-59-63** sts. Continue in Moss st stripes as for Front.

#### Sleeves:

When work measures **14-16-18-19** cm (**5½-6¼-7-7½** in) [**56-64-72-76** rows] total, cast on **3-3-3-4** new sts at beginning of next 2 rows.

Continue on the **57-61-65-71** sts obtained.

#### Opening:

The sweater will now be worked in 2 separate pieces.

#### 1ST PART:

When work measures approximately **16-19-22-24** cm (**6¼-7½-8½-9½** in) [**65-77-89-97** rows] ending on a RS row cont as follows:

**Next row (WS):** Work **30-32-34-37** sts in Moss st and leave the remaining **27-29-31-34** sts on a spare needle.

Continue in Moss st on these **30-32-34-37** sts.

#### Neck:

When work measures **23-26-29-31** cm (**9-10-11¼-12** in) [**92-104-116-124** rows] total cast off **10-11-11-12** sts at the beginning of next RS row (opening edge). Work 1 row in Moss st.

**Next row (RS - dec):** Work 2 sts Moss st, k3tog, pattern to end. Work 1 row in Moss st.

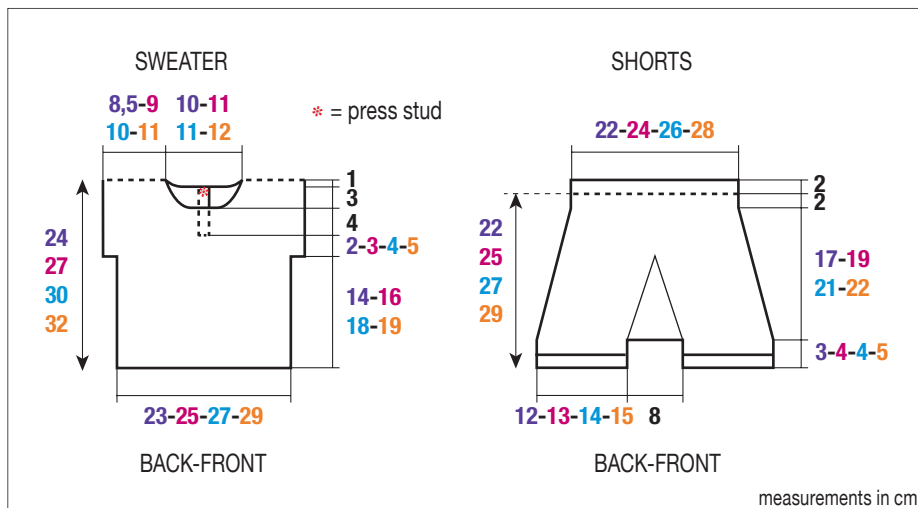

### Shoulder:

When work measures **24-27-30-32** cm (**9¼-10½-11¼-12½** in) [**96-108-120-128** rows] total leave the remaining **18-19-21-23** sts on a spare needle.

### 2ND PART:

Pick up the **27-29-31-34** sts left on the spare needle, pick up 1 st behind each of the 1st 3 sts at the opening edge of the 1st part. Continue on these **30-32-34-37** sts in Moss st.

### Neck:

When work measures **23-26-29-31** cm (**9-10-11¼-12** in) [**92-104-116-124** rows] total cast off **10-11-11-12** sts at the beginning of next WS row (opening edge).

**Next row (RS - dec):** Work in Moss st until 5 sts remain on LH needle, sl1, k2tog, pssso, work 2 sts Moss st.

### Shoulder:

When work measures **24-27-30-32** cm (**9¼-10½-11¼-12½** in) [**96-108-120-128** rows] total leave the remaining **18-19-21-23** sts on a spare needle.

### FINISHING:

Join the shoulder seams using a chain stitch seam on the WS (see: Knitting: Stitches/Techniques/Tips).

Sew side seams.

Sew on press stud (see diagram for positioning).

Secure & weave in all ends.

## SHORTS

### BACK:

#### Right leg:

Using 4.0 mm needles & col B cast on **29-31-33-35** sts. Continue in Moss st stripes as for Sweater for 6 rows.

Starting with a knit row continue in St st.

When work measures **3-4-4-5** cm (**1-1½-1½-2** in) [**10-12-12-14** rows] total, leave the sts on a spare needle.

#### Left leg:

Work as for Right leg.

#### Crotch:

Pick up the sts for the two legs on the same needle, casting on 17 new sts between each leg.

Starting with a knit row continue in St st over the **75-79-83-87** sts obtained until work measures **1.5** cm (**1/2** in) [**4** rows] total from the start of the crotch.

**Next row (RS - dec):** k**27-29-31-33**, sl1, k1, pssso, k**17**, k2tog, k**27-29-31-33**.

Work **3** rows in St st on the remaining **73-77-81-85** sts.

**Next row (RS - dec):** k**27-29-31-33**, sl1, k1, pssso, k**15**, k2tog, k**27-29-31-33**.

Work **3** rows in St st on the remaining **71-75-79-83** sts.

Rep the last 4 rows, working 2 sts less in the middle on every decrease row, 5 more times.

Continue on the remaining **61-65-69-73** sts until work measures **20-23-25-27** cm (**7¾-9-9¾-10½** in) [**56-64-68-74** rows] total.

**Next row (RS - dec):** k**2-4-6-8**, k2tog, \*k4, k2tog\*, rep from \* to \*, ending with k**3-5-7-9** (= 10 decreases).

Continue on the remaining **51-55-59-63** sts until work measures **24-27-29-31** cm (**9¼-10½-11¼-12** in) [**68-76-80-86** rows] total, cast off all the sts.

### FRONT:

Work the same as for Back.

### FINISHING:

Sew each leg up to the crotch, then sew the side seams of the shorts.

Fold 2 cm to the WS of the waist and hem in place, slip the elastic through adjusting to the correct size.

Secure & weave in all ends.

## NOTES

# le Wooling

## SPECIAL ISSUE

NEW

2  
DIFFERENT  
LE WOOLING  
SPECIAL  
ISSUES



SPECIAL ISSUE - ORILIS  
WOMEN - KIDS - LAYETTE  
10 PATTERNS - REF. 72688

SPECIAL ISSUE - COTON SATINÉ  
WOMEN - KIDS - LAYETTE  
10 PATTERNS - REF. 72683

*Browse the  
magazines online*

ref. 726.88

