

le Wooling

SPECIAL ISSUE

Coton Satiné



BERGERE
DE FRANCE

10 PATTERNS

Coton Satiné

With its even brightness this remarkable yarn knits as easily as it crochets. With its pleasant, soft feel you can create beautiful summer outfits for the whole family. Satin-finish cotton is the biggest cotton in the Bergère de France collection. You're going to love how quickly you'll complete your creations with this yarn.

PRESENTATION

50g ball of yarn = 115 meters approximately



DK

SHADES

Range of 13 shades (to discover on page 14).

COMPOSITION

100% mercerized cotton

CARE INSTRUCTIONS

Machine wash, wool cycle.

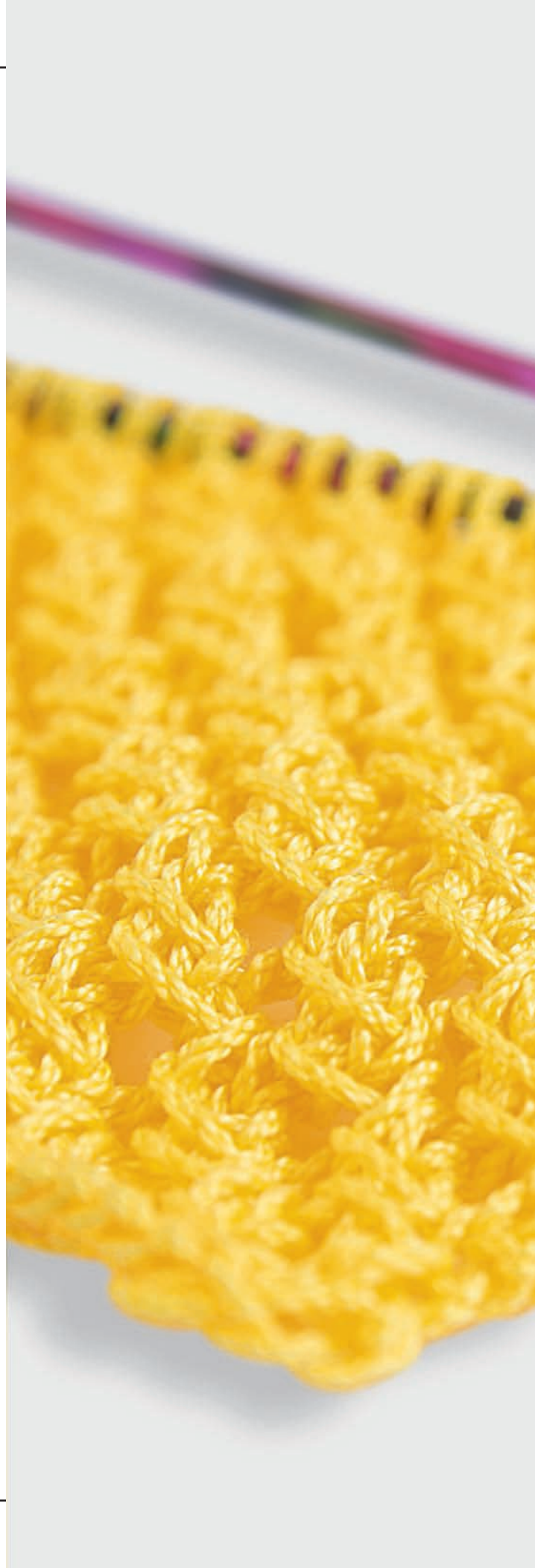

01

TOP

Sizes S M L XL

COTON SATINÉ

Jaune 5 6 6 7 balls

Needles 4.5 mm**BBBBBB**
INTERMEDIATE

SUN



02

WRAP CARDIGAN**One size****COTON SATINÉ**

Blanc 11 balls

Crochet hook 3.5 mm

5 meters of white double

sided satin ribbon

10 mm ref. 53610

BBBBBB
EASY

HOODED JACKET

Sizes	S	M	L	XL	XXL
-------	---	---	---	----	-----

COTON SATINÉ

Kaki	14	16	17	19	20 balls
Framboise	3	3	3	4	4 balls
Jaune	3	3	3	3	3 balls
Noir	2	3	3	3	3 balls

Crochet hook 3.5 mm

Stitch markers ref. 68395

1 khaki separating zipper:

60 cm long ref. 50102

65 cm long ref. 25911

BBBBBB
INTERMEDIATE



04

LACY SWEATER**Sizes S M L XL****COTON SATINÉ**

Écru 10 11 12 13 balls

Needles 3.5 & 4.0 mm

BBBBBB
INTERMEDIATE

05

TOP

Sizes	S	M	L	XL
-------	---	---	---	----

COTON SATINÉ

Gris	2	3	3	3 balls
Noir	2	2	2	2 balls
Fushia	1	1	2	2 balls

Needles 4.0 mm

1 cable needle

Crochet hook 3.5 mm

Stitch markers ref. 68395

1 black non separating zipper

22 cm (8½ in) ref. 43716

BBBBBB
INTERMEDIATE



06

SLEEVELESS TOP

Sizes 4 6 8 10 12 yrs**COTON SATINÉ**

Rouge 3 4 4 5 6 balls

Needles 5.5 mm

Stitch markers ref. 68395

BBBBBB
BEGINNER



07

KNIT OVERALLS

Sizes	1	3	6	12 mths
-------	---	---	---	---------

COTON SATINÉ

Framboise	2	3	3	4 balls
-----------	---	---	---	---------

Needles 3.5 & 4.0 mm

90 cm (35½ in) of red gros

grain ribbon 10 mm ref. 30926

5 see-through press studs

Ø 10 mm ref. 60467

BBBBBB
 EASY

08

VEST

Sizes	4	6	8	10	12 yrs
-------	---	---	---	----	--------

COTON SATINÉ

Turquoise	3	3	4	4	5 balls
-----------	---	---	---	---	---------

Marine	1	1	1	1	1 ball
--------	---	---	---	---	--------

Needles 3.5 & 4.0 mm

BBBBBB
 INTERMEDIATE
I
C
EC
R
E
A
M

09

HOODED JACKET

Sizes	3	6	12	18	24 mths
-------	---	---	----	----	---------

COTON SATINÉ

Beige	3	4	4	5	5 balls
Paille	1	1	1	1	1 ball

Needles 3.5 & 4.0 mm

1 ecru thin separating zipper:

20 cm long ref.67961

25 cm long ref.67966

30 cm long ref.67974

BBBBBB
EASY



10

SUMMER DRESS**Sizes 3 6 12 24 mths****COTON SATINÉ**

Paille 2 2 3 3 balls

Blanc 1 1 1 1 ball

Needles 4.0 mm

2 pearly square buttons

10 mm ref. 42513

BBBBBB
EASY

Coton Satiné

SHADES



ÉCRU
35231



PAILLE
35199



JAUNE
35216



ROUGE
35219



FRAMBOISE
35225



FUSHIA
35205



KAKI
35242



BEIGE
35214



BLANC
35208



GRIS
35227



TURQUOISE
35236



MARINE
35203



NOIR
35238

PATTERN INSTRUCTIONS

BERGERE
DE FRANCE

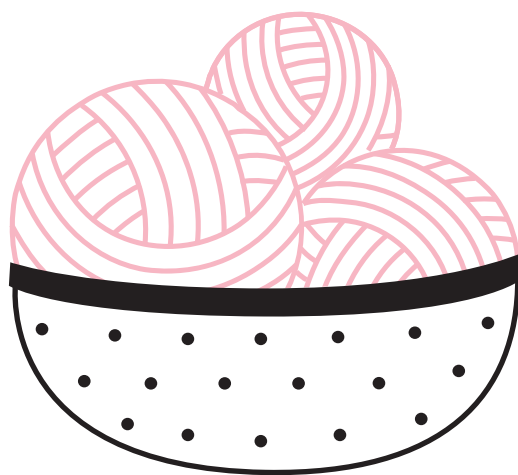

DON'T PANIC !

BERGERE DE FRANCE IS
ACCOMPANYING ME STEP BY STEP



OUR DEDICATED EMAIL

Stuck in the middle of your work? Need a clarification concerning the instructions? Do not hesitate to contact us. An expert knitter will take the time to provide the answers and all the help you need.

knittingquery@bergeredefrance.com

From Monday to Friday, during office hours



OUR WEBSITE

www.bergeredefrance.co.uk/knitting-basics-get-started

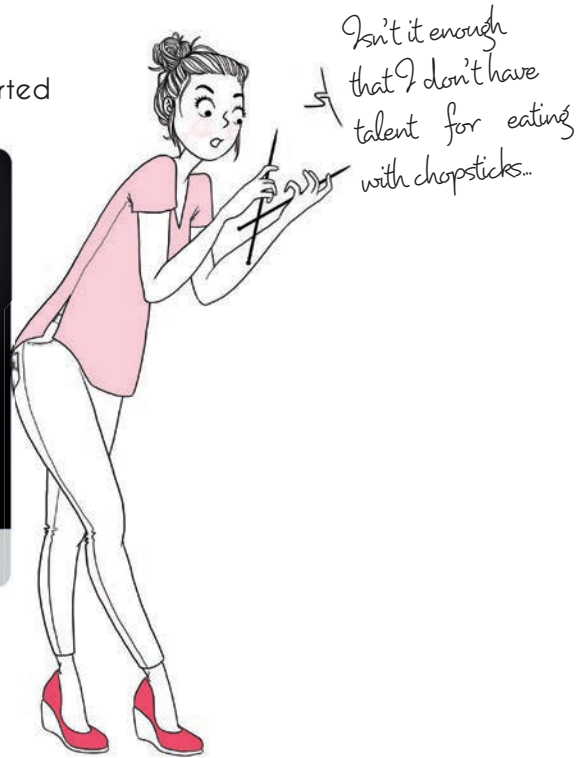
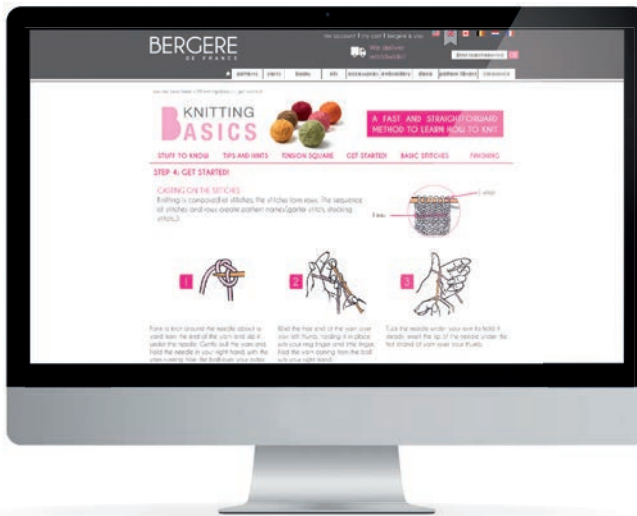

OUR YOUTUBE CHANNEL

All our video tutorials (in french) are available at :
www.youtube.com/bergerefr

Stuck in the middle of your work... Need some advice from an expert?



knittingquery@bergeredefrance.com

From Monday to Friday, during office hours

CHECK YOUR TENSION

Before you start working on a pattern, make sure that the end-result will be perfect by making a swatch.

You've got to make sure that your knitting tension is exactly the same as the tension in our pattern. If it isn't, your garment is likely to be too big or too small.

HOW TO MAKE A SWATCH ?

Using the yarn, needles, and stitch specified for the pattern, work a square at least 6 in (15 cm) on a side.

Iron the square lightly on the wrong side under a damp cloth or using a steam iron. If the swatch is worked in ribbing, stretch it slightly. With a ruler, count the sts to equal 4 in (10 cm) widthways and 4 in (10 cm) lengthways.

Compare the result with the sample given in our instructions.

Your tension square matches ours !

You can start your knitting, you can be sure your project will have the same dimensions as the grid.

Your sample has more stitches and rows ?

Your knitting is too tight. Make another swatch with needles one size larger.

Your sample has fewer stitches and rows ?

Your knitting is too loose. Make another swatch with needles one size smaller.

When your swatch matches ours, you're ready to follow the instructions.

You can expect to end up with a garment that's just right.

BEWARE: It is important to achieve an exact number of stitches for the design to fit correctly. However, the number of rows can be adapted depending on the height indicated in cm.



Read the instructions

Before you start knitting we advise you to read through the instructions, trying to imagine all of the steps you will be taking. All patterns are well detailed.

The instructions are given for several sizes. We suggest that you circle or underline the numbers that correspond to the size you intend to make. If there's only one number, it applies to all the sizes.

CASTING OFF THE STITCHES

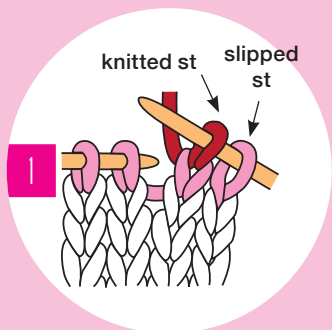

On the right side of work, slip 1 stitch onto the right needle as if to purl.

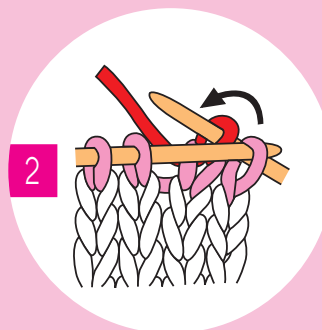

Using the left needle pass the slipped stitch over the top of the 2nd stitch on the right hand needle. You have cast off 1 stitch.

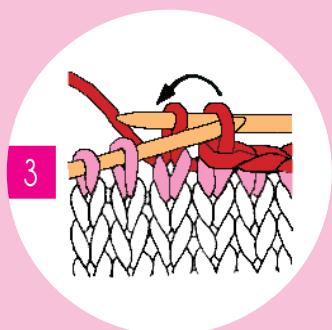

Knit the next stitch and with the left needle, pass the 1st stitch on needle over the top of the current stitch. One stitch remains on right needle.

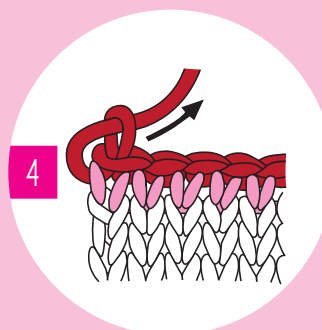

Repeat this sequence until all stitches from the left needle have been worked and only one stitch remains on right needle. Cut thread 10 cm from work and pull through remaining stitch using needle.

WEAVING IN THE YARN

After sewing together the pieces you must weave in the loose ends. On the wrong side of the knitting using the yarn needle, slip the yarn end through a few stitches and then cut the yarn.

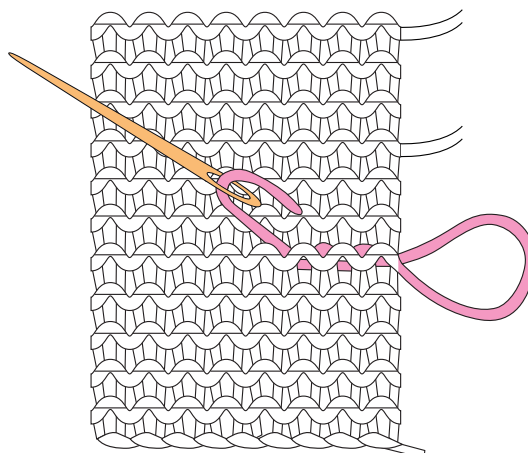

BASIC KNITTING STITCHES

1/1 rib

Cast on an uneven number of stitches.

Row 1 : knit 1, purl 1, and repeat these 2 stitches to the last stitch, knit 1.

Row 2 and subsequent rows : purl over the purl stitches, knit over the knit stitches. Repeat these 2 rows.

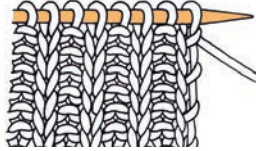

2/2 rib

Cast on a multiple of 4 stitches + 2 (e.g., 22 stitches).

Row 1 : knit 2, purl 2, and repeat to the last stitches, knit 2.

Row 2 and subsequent rows : purl over the purl stitches, knit over the knit stitches. Repeat these 2 rows.

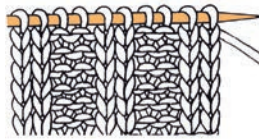

Seed or moss stitch

Cast on an uneven number of stitches.

Row 1 : knit 1, purl 1, repeat these 2 stitches.

Row 2 and subsequent rows : purl over knit stitches, knit over purl stitches.

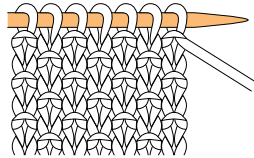

Corn stitch

Cast on an uneven number of stitches.

Row 1 : knit 1, purl 1, repeat these 2 stitches, ending with knit 1.

Row 2 : purl over purl stitches, knit over knit stitches.

Row 3 : purl over knit stitches, knit over purl stitches.

Row 4 : purl over purl stitches, knit over knit stitches. Repeat these 4 rows.

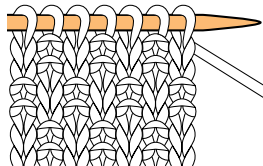

Yarn forward

By bringing the yarn forward you add a stitch and make an eyelet.

Bring the yarn in front of the work then over the right-hand needle.

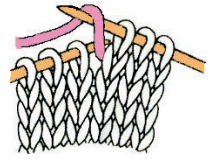

Work the next stitch on the left-hand needle. The yarn forward loop forms an extra stitch with a hold at its base on the right-hand needle.

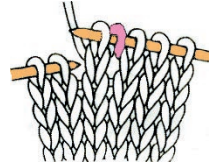

Next row : When you come to the yarn forward loop, purl it as you would any other stitch; you now have 1 extra stitch.

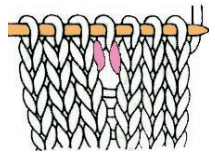

Knit 2 together

Put the right needle through the 2nd then the 1st stitch on the left hand needle.

Knit the 2 stitches together (wrap yarn around right hand needle and pull through the 2 stitches on the left needle).

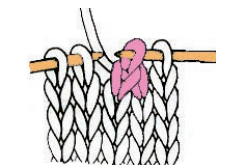
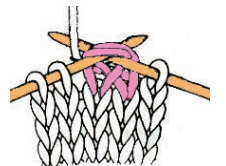
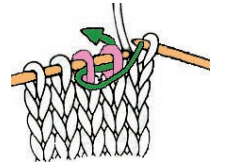

By knitting 2 stitches together you will have 1 less stitch on the needle..

Slipped stitch

With the yarn at the back of the work, insert the right-hand needle into the next stitch from right to left, as if to purl. Slip the stitch on to the right-hand needle and continue working as given.

Next row : Purl the slipped stitch.

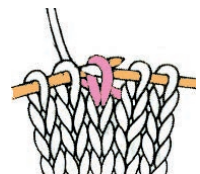

Single decrease

Slip a stitch on to the right-hand needle as if to knit.
Knit the next stitch.

Using the left-hand needle, pass the slipped stitch over the stitch you just worked.

After working a single decrease, you have 1 less stitch on the needle.

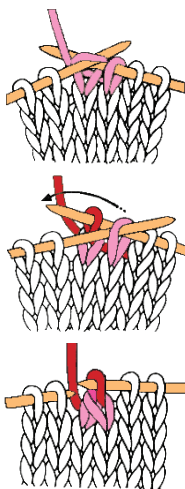

Double decrease

Slip a stitch on to the right-hand needle as if to knit.
Knit the next 2 stitches together.

Using the left-hand needle, pass the slipped stitch over the 2 stitches you just worked.

After working a double decrease, you have 2 fewer stitches on the needle.

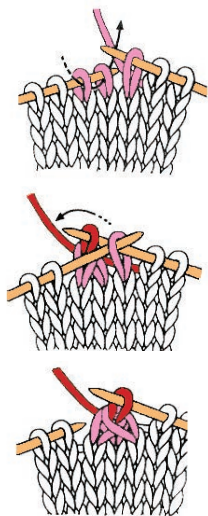

Twisted knit stitch

Knit the stitch, inserting the needle through the back loop to twist the new stitch.



Twisted purl stitch

Purl the stitch, inserting the needle under the back loops to twist the new stitch.



Nonstitch or suppressed stitch

Sometimes, the number of stitches varies from row to row in a pattern; the nonstitches or suppressed stitches are represented by black squares on the chart. When you follow the chart, do not try to work the black squares but go directly to the next square.

Working in reverse

When instructed on the front of a garment, for example a jacket, to work the other front in reverse. If you increased or decreased at the beginning of a right side row on the first front you must increase or decrease at the end of the right side row on the second front at the same measurement. The positions of the stitches used will also be reversed, if you ended with a ribbed section for a border on the first front you will start with the ribbed section on the second front. However the pattern should remain the same (do not reverse a cable twist for example).

Double decrease slip slip knit

Slip 2 stitches as if to knit. Knit 1.
Pass the 2 slipped stitches over the stitch just worked..

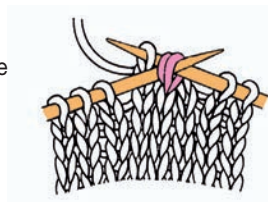

Raglan decreases

This method of decreasing is always used for Raglan sleeves. It forms a line of slanting stitches parallel with the seam. The decrease is worked with the right side facing, one or more stitches from the edge.

The example shows decreases 1 stitch from the edge :

At beginning of row, with right side facing, knit 1, slip 1, knit 1, pass slipped stitch over (See above).

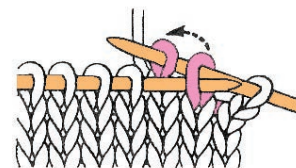

Continue the row as indicated. When 3 sts are left on the left-hand needle, knit the next 2 sts together (see knit 2 together, page 7), knit the last stitch.

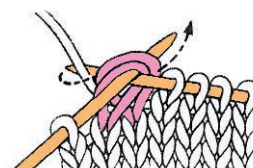

Increases within a row

When you need to increase a stitch in a row you will need to work twice into one stitch.

Put your right needle through the loop of the stitch below the current stitch on your left needle, knit into this stitch.

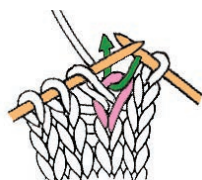

Work the stitch on your left needle as normal.

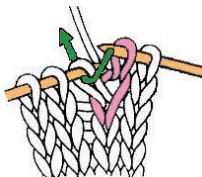

You will have one more stitch.

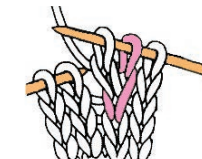

Increases 1 stitch in from edge of row

These increases are always done on the right side of work, 1 stitch in from the edge.

At the beginning of the row, on the right side of work, knit 1 stitch, put the right needle under the horizontal thread before the first stitch on left needle.



Put this strand onto the left needle.



Knit into the back of this loop to twist it.



This prevents a gap forming at the bottom of the increased stitch. Continue along the row.

At the end of the row, on the right side of work, work until 1 stitch remains on left needle, pass right needle through the back of the horizontal thread between stitches and place on left needle.

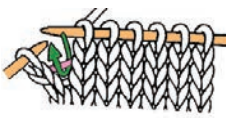

Knit this stitch as normal then knit last stitch.



Increases of one stitch or more at end of work

Wrap yarn around the needle at the beginning of the row as many times as you need stitches. If you are increasing at each end you will also need to do at the end of the row.

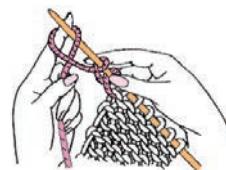

Work these stitches as knit or purl in the pattern required.

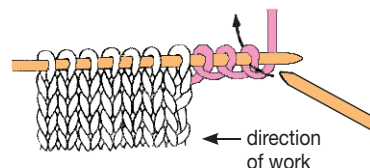

Stretch cast-on

Short Row Shaping Short rows are rows which are not worked in their entirety, this gives a curve to the work as more rows are completed on one side than the other. They can be used on just one side of work or both sides, creating a gentle slope instead of the stepped edge created by casting off a series of stitches.

When told to turn the work during the progress of a row you will not work the remaining stitches on the left hand needle.

To avoid creating a hole when you turn the work, after turning, with the yarn at the front of work (as if about to purl), slip the 1st stitch on the left hand needle onto the right hand needle as if to purl, then take yarn back to back of work (called a wrap) & work the remaining stitches as normal.

When you have finished the short row shaping and need to knit across the whole row you need to knit together the wrap & the next stitch. Take the wrapped stitch back over the top of next stitch then knit both together.

Stretch cast-on

Take a ball of yarn in a contrasting colour and cast on half the required number of stitches plus 1 extra.

For example : If the pattern tells you to cast on 45 stitches, using the contrasting yarn cast on $\frac{45+1}{2} = 23$ stitches.

Now, using the yarn you intend to work the pattern with, work as follows :

Row 1 : * knit 1, bring yarn forward under the needle, yarn over *. Repeat from * to *. End with knit 1.

Row 2 : Slip the first stitch as if to purl on to the right-hand needle, *pass yarn to back, knit 1 (= yarn forward loop from previous row), bring yarn forward, slip next stitch as if to purl *. Repeat from * to *.

Row 3 : * knit 1, yarn forward, slip 1 stitch as if to purl, pass yarn to back *. Repeat from * to *. End with knit 1. Continue working in 1/1 rib, beginning Row 1 with purl 1. After completing the ribbing, pull out the contrasting yarn.

Casting off stitches

1) To form armholes or collar

You must cast off stitches at the beginning of rows:

On the right side of work, slip 1 stitch onto the right needle as if to purl. Knit the following stitch.

Using the left needle pass the slipped stitch over the top of the 2nd stitch on the right hand needle. You have cast off 1 stitch.

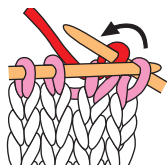
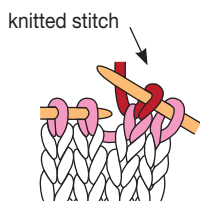

Knit the next stitch and pass stitch on right needle over the top, you have cast off a 2nd stitch. Repeat this step for the required number of stitches. On the following row, on the wrong side of work, cast off in the same way but work the stitches as purl stitches.

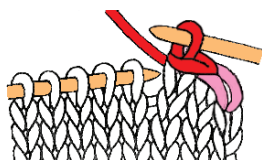

On the following row, cast off the next number of stitches indicated in the pattern to obtain a sloped edge.

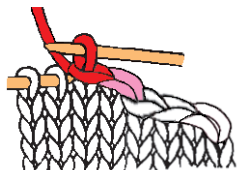

2) When work is complete, to cast off all stitches.

Start to cast off as for casting off at the beginning of row: Slip the 1st stitch, knit the following stitch.

With the left needle, pass the slipped stitch over the top of the knitted stitch.

Knit the next stitch and with the left needle, pass the 1st stitch on needle over the top of the current stitch. One stitch remains on right needle.

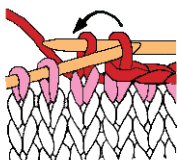

Repeat this sequence until all stitches from the left needle have been worked and only one stitch remains on right needle. Cut thread 10 cm from work and pull through remaining stitch using needle.

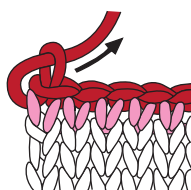

Small buttonholes

For a small buttonhole, one stitch is sufficient to make a buttonhole:

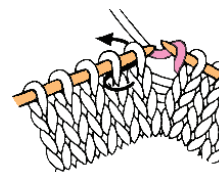

Yarn over needle, then knit 2 together. On the next row work the yarn over needle as normal.

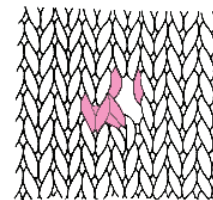

Buttonholes

1st row : Work to where the buttonhole should be, cast off the number of sts indicated in the pattern and work to end of row.

2nd row : Work to cast off sts, cast on the same number of sts as 1st row and work to end of row.

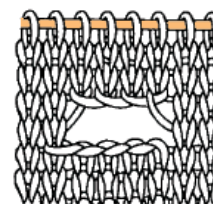

No-cut buttonholes

Using a sewing needle, pick up the horizontal strand of the stitch where you want to place the buttonhole, pull it up and attach it 2 rows higher with a few little stitches on the wrong side of the work. Repeat with the horizontal strand below the first strand, and attach it in the same way 2 rows down.

Pattern stitches

Instructions for pattern stitches are always given row by row, as well as in chart form, with each square on the chart representing 1 stitch and 1 row.

The accompanying legend explains the terms and matches the symbols to the stitches. The chart shows the right side of the work, it is not always possible, however, to include all the subtleties of a pattern stitch in a chart. For that reason, we advise you to always read the row-by-row instructions, even if you prefer to use a chart.

Knit over knit and purl over purl is an instruction often used for ribbing and pattern stitches.

Cables

It is easy to work narrow cables over 2 stitches :

Right cross 2 (2CR): Passing in front of the work, knit the 2nd st on the left-hand needle then knit the first stitch; slip both stitches on to the right-hand needle at once.

Left cross 2 (2CL): Passing behind the work, knit the 2nd st on the left-hand needle then knit the first stitch as usual; slip both stitches on to the right-hand needle at once.

A cable made up of 3 or more stitches requires the use of a cable needle.

Cable 4 left (front) :

Slip 2 stitches on to a cable needle in front of work, knit 2, then slip the 2 stitches from the cable needle on to the left-hand needle and knit 2.

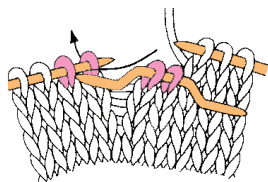

Cable 4 right (back) :

Slip 2 stitches on to a cable needle at back of work, knit 2, then slip the 2 stitches from the cable needle on to the left-hand needle and knit 2.

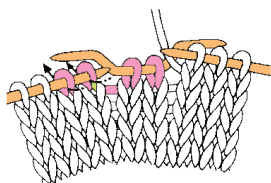

Picking up stitches

When the different sections of the garment are completed, you may need to pick up stitches at the edge of your work, for example on the collar or front borders

To pick up the stitches knit wise, put needle through the middle of each stitch on the last row and pick up the loop. When you are picking up stitches on rows where there are more rows than stitches required work through 2 or 3 rows then skip 1 row to obtain the number of stitches required in the pattern.

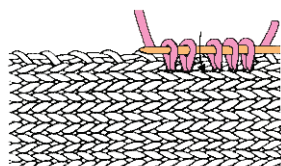
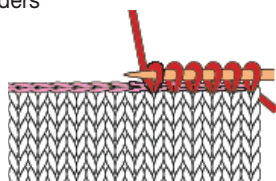

Backstitched seam

Place the 2 pieces right sides together. Thread a tapestry needle with the matching yarn, insert the needle through both thicknesses, matching stitch for stitch, and bring the needle out 2 rows further along.

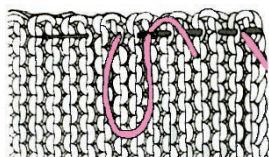

Grafting

This technique is widely used in European patterns, but is not so popular among UK and US knitters. When you have completed the sections, do not cast off, but leave the stitches on a spare needle.

Thread a tapestry needle with the matching yarn. Work with right side facing. Place the 2 spare needles together.

Insert the tapestry needle through the centre of the first stitch on the front needle as if to purl (leave the stitch on the needle),

– and bring the tapestry needle out at the centre of the first stitch on the back needle as if to knit (leave the stitch on the needle),

*bring the tapestry needle through the centre of the first stitch on the front needle again as if to knit and slip off the stitch,

– Insert the tapestry needle through the centre of the next stitch on the front needle as if to purl (leave the stitch on the needle),

– bring the tapestry needle out at the center of the next (first) stitch on the back needle again as if to purl and slip off the stitch,

– Insert the tapestry needle through the centre of the next stitch on the back needle as if to knit (leave the stitch on the needle)*, maintaining an even tension. Repeat the movement until the seam is complete.

Work all the free stitches into the seam one by one and let the stitches drop off the spare needles as they are grafted together.

The finished seam will look identical to a row of knitting.

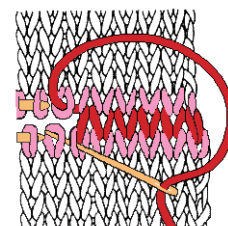
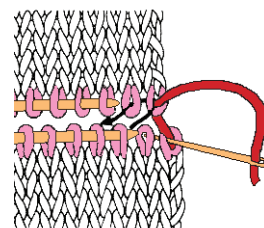

Invisible seam

Following the sketch, working with the 2 pieces to be joined, pick up the horizontal thread between the first and second stitches and pull firmly to bring the edges together and make the join invisible. If the edge is very uneven, work the thread between the second and third stitches.

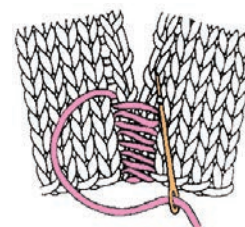

You may also use an invisible seam to join at the shoulder. In that case, pick up the 2 upright strands of a stitch 1 row in from the edge.

Fair Isle

Fair Isle and contrasting colour patterns.

These patterns are worked in stocking stitch using several colours to make a design shown on a chart.]

Each square on the chart represents 1 stitch and 1 row. A legend accompanying the chart indicates the colours. Read the chart beginning at the bottom row, from right to left for the right side of the work, and from left to right for the wrong side rows.

KNITTED PATTERNS

Various techniques are used according to the complexity of the pattern.

- When the motifs of the design are small and close together, you may let the yarn not in use run loosely at the back of the work. Make sure that you don't pull the yarn taut or it will pucker the pattern.
- When the motifs are far apart or very wide, pass the yarn not in use behind the work attaching it along with the one that is in use : hold the yarn not in use in your left hand, then work a stitch passing the right-hand needle under that yarn but taking care not to actually knit the yarn. Repeat this movement every other stitch.
- When the motifs are very large or use several colours, do not try to pass the yarn at the back of the work. Instead, use several balls of each colour, as needed, using the intarsia technique. Each time you change yarn colour, make sure that you twist the yarns loosely at the back of the work to avoid forming holes in the texture.

In all three cases, take care to work evenly, especially where the colours change and stitches tend to be loose.

EMBROIDERED PATTERNS

Embroidery can be used to advantage instead of knitted patterns when the motifs are made up of relatively few stitches.

This technique avoids the problems of disposing of extra yarns at the back of the work. For embroidery, form open chain stitch with a tapestry needle, working from right to left.

Bring the needle from wrong side to right side at the base of the first stitch, insert the needle from right to left under both strands of the stitch above the one being worked (see sketch no. 1), then insert the needle again at the base of the stitch being worked and bring it out at the base of the next stitch (see sketch no. 2).

Use this technique to embroider the number of stitches indicated. After the last stitch, bring the needle out at the base of the row above. Turn the work to start again from right to left.

Sketch no 1

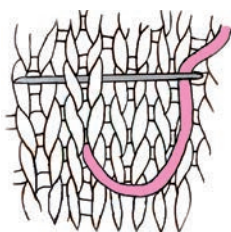

Sketch no 2

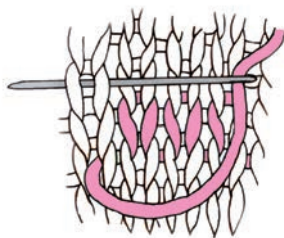

Grafting a border

When the border is finished, work a few rows of stocking stitch using a contrasting yarn.

Take the work off the needle and press the stocking stitch section with a warm iron under a damp cloth to prevent it from unraveling. Pin the border to the finished garment, matching the stitches. Unravel all but the last row of stocking stitch. Now graft the stitches, waving the tapestry needle in and out, and unravel the last row of stocking stitch as you go. Bring the needle from back to front through the centre of the second stitch, work a back stitch into the first stitch and bring the needle out again at the centre of the third stitch; now work a backstitch again into the second stitch and continue thus with backstitching as far as the last stitch.

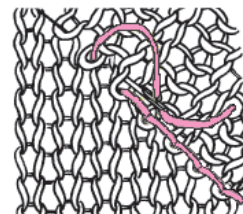

Chainstitch shoulder seam

CHAINSTITCH SHOULDER SEAMS

or 3 needles cast off or 3 needles bind off

Leave the remaining shoulder stitches on a spare needles. Place back and front with wrong sides together.

Using a third needle, knit together the first stitch from the front needle with the first from the back needle, and repeat with the second stitch from each needle. You now have 2 stitches on the right-hand needle.

Pass the first stitch over the second, as in casting off. Continue thus until you have cast off all the shoulder stitches. The result is a chain that shows on the right side and a shoulder seam that will not go out of shape. To obtain an invisible seam on the right side, place back and front with right sides together.



BASIC CROCHET STITCHES

Chain stitch (ch or ch st)

The first stitch in crochet. Make a loop. Insert the hook in the loop. * Pass the hook under the yarn for a yarn over (yo), and pull the yo through the loop = 1 ch st. Rep from * to work as many ch sts as needed.

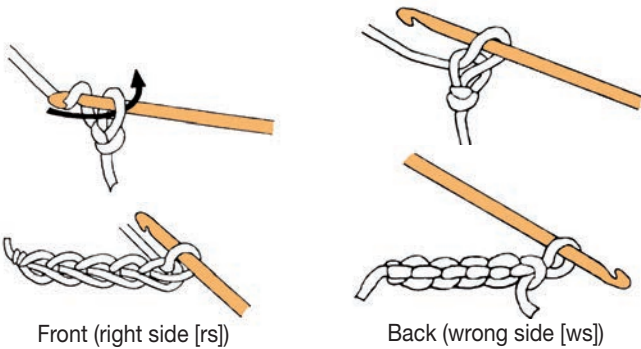

Stitch (sl st)

Insert the hook into a stitch, yo and pull through the loop on the hook in a single movement.

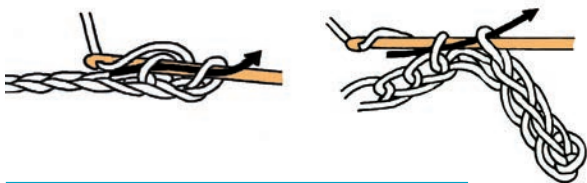

Single Crochet (UK: Double Crochet) = sc (uk: dc)

Insert the hook into a stitch, yo and draw up loop, yo and through both loops on hook.

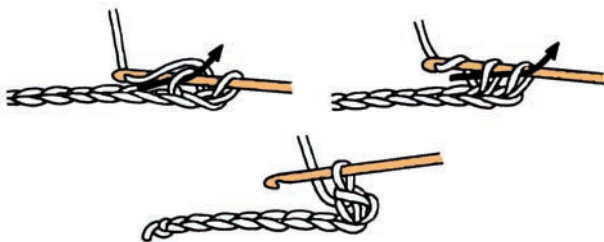

Crab Stitch (sc (uk: dc) worked from left to right)

Beg at left edge: * insert hook into a stitch, yo and draw up lp, yo and through both lps on hook *, rep from * to *, inserting hook into preceding st..

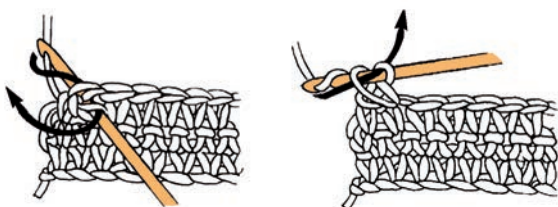

Half Double Crochet

(UK: Half Treble) = hdc (uk: half tr)

Yo, insert the hook into a stitch, yo and draw up loop, yo and through all 3 loops.

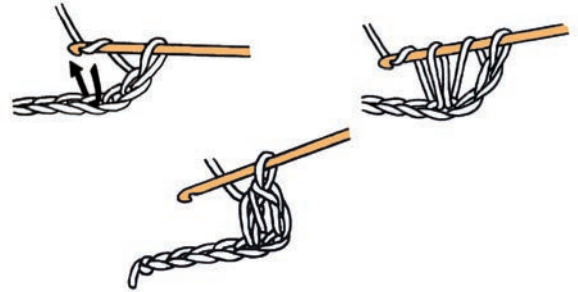

Double Crochet

(UK: Treble) = dc (uk: tr)

Yo, insert the hook into a st, yo and draw up loop, yo and through first 2 loops on hook, yo and through remaining 2 loops.

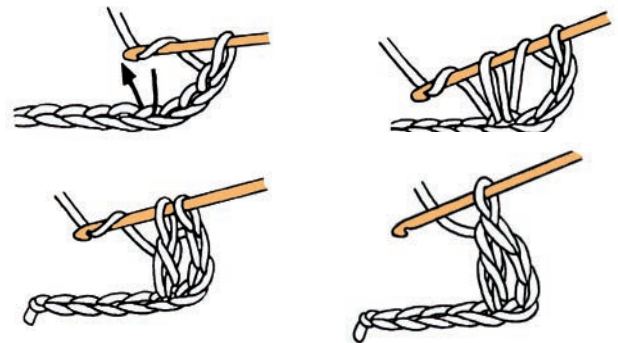

Treble (UK: Double Treble) = tr (uk: dbl tr)

Yo twice, insert the hook into a stitch, yo and draw up loop, yo and through first 2 loops on hook, yo and through 2 loops on hook, yo and through remaining 2 loops.

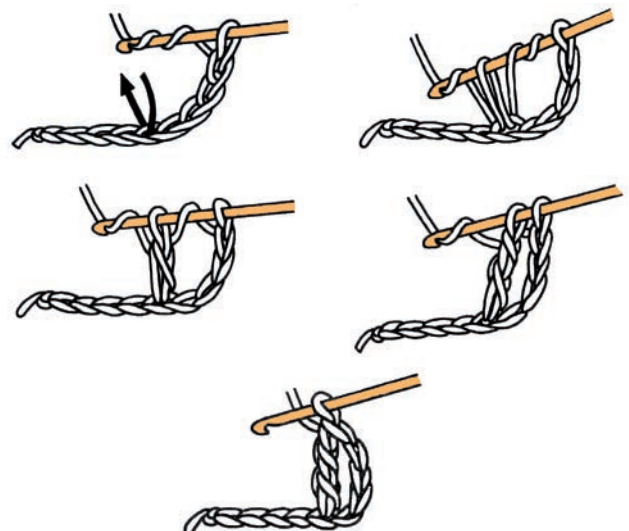

Double Treble

(UK: Triple Treble) = dbl tr (uk: tr tr)

Yo 3 times, insert the hook in a stitch, yo and draw up loop, yo and through first 2 loops on hook, yo and through 2 loops on hook, yo and through 2 loops on hook, yo and through remaining 2 loops.

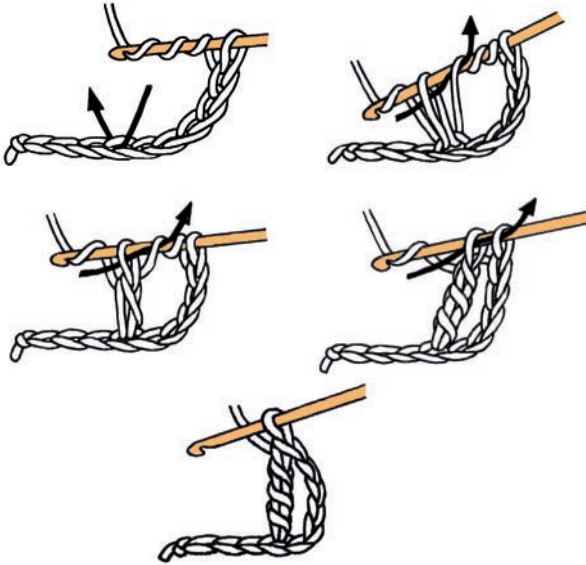

Beginning with a round

Wind the yarn around the tip of your index finger, slip the hook through the loop, yo and draw up lp, yo and through the loop as shown, then work as many dc as indicated. To end the first round, work a sl st over the first dc and pull gently but firmly on the end of yarn to close up the initial ring..

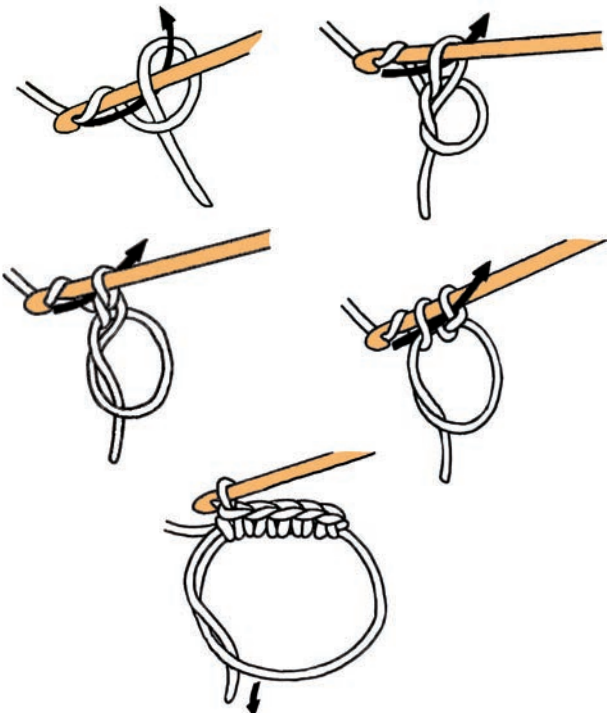

2 Single Crochet Together (UK: 2 Double Crochet Together) = 2 sc tog (uk: 2 dc tog)

Leaving last loop of each st on the hook, work incomplete sc as follows: Insert hook into a st, yo and draw up loop, insert hook into next st, yo and draw up loop, yo and through all remaining 3 loops.

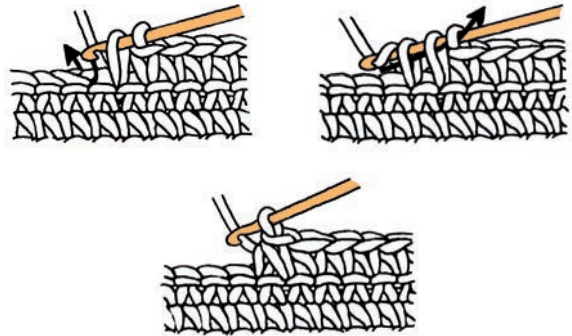

3 single crochets together (3 sc tog) [3 double crochets together : 3 dc tog (UK)]

Leaving last loop of each stitch on the hook, work incomplete sc as follows; insert hook in a stitch, yo and draw up loop, insert hook in next stitch, yo and draw up loop, insert hook in next stitch, yo and draw up loop, yo and through all remaining 4 loops at once.

2 Double Crochets Together

(UK: 2 Trebles Together) = 2 dc tog (uk: 2 tr tog)

Leaving last loop of each st on the hook, work incomplete dc as follows : yo, insert the hook into a st, yo and draw up loop, yo and through first 2 loops on hook, yo, insert hook into next st, yo and draw up loop, yo and through first 2 loops, yo * and through all 3 remaining loops.



3 Double Crochets Together (UK: 3 Trebles Together) = 3 dc tog (uk: 3 tr tog)

As for 2 dc tog as far as *, then insert hook into next st, yo and draw up loop, yo and through 2 loops on hook, yo and through all 4 remaining loops.

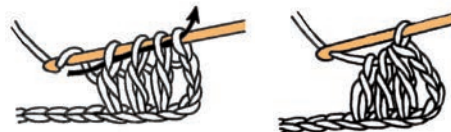

2 or 3 Double Crochets Together (UK: 2 or 3 Trebles Together) = 2 or 3 dc tog (uk: 2 or 3)

As for dc tog (tr tog), but beg by working yo twice.

1 - TOP



Quality: **COTON SATINÉ**
Needles: **4.5 mm**

Sizes		S	M	L	XL
Quality COTON SATINÉ		Number of balls			
Jaune	35216	5	6	6	7

79-85-94-103 sts in Patt st,
1-2-2-2 sts in St st.

Armholes:

Please note:

Each yo must be compensated by the cast off st of a set of 2 special sts.

When it's no longer possible to work this group of sts, replace those sts by k sts.

Cast off at the beg of every row as foll:

S: 3 sts twice, 2 sts twice, 1 st 8 times.

M: 3 sts twice, 2 sts 4 times, 1 st 6 times.

L: 3 sts twice, 2 sts 4 times, 1 st 8 times.

XL: 3 sts twice, 2 sts 6 times, 1 st 10 times.

Cont on the rem **63-69-76-79** sts until piece measures **41-43-45-47** cm (**16-17-17½-18½** in) [**106-112-116-122** rows] total.

Neck:

Cast off the **27-29-32-33** center sts. Cont each side separately and cast off on neck side every 2nd row: 3 sts once, 2 sts once.

Shoulders:

When piece measures **43-45-47-49** cm (**17-17½-18½-19** in) [**112-118-122-128** rows] total, leave on hold the rem **13-15-17-18** sts.

FRONT:

Work as for back up to armholes.

Armholes:

Cast off as for back.

Neck:

When piece measures **31-33-35-37** cm (**12¼-13-13¼-14½** in) [**80-86-90-96** rows] total, cast off the **17-19-22-23** center sts. Cont each side separately and cast off on neck side every 2nd row: 3 sts once, 2 sts once, 1 st once; every 4th row: 1 st twice; then every 6th row 1 st twice.

Shoulders:

Leave on hold as for back.

FINISHING:

Join right shoulder on WS using the 3 needle bind off technique (See "Knitting: Stitches/Techniques/Tips").

Neck borders: Pick up and k **100-104-108-112** sts along neck edge. Then cast off all sts kwise on WS.

Join left shoulder on WS using the 3 needle bind off technique and join the shorter ends of border.

Armhole borders: Pick up and k **92-96-104-108** sts around each armhole edge. Then cast off all sts kwise on WS.

Sew side seams of top.

Fringes:

– Make **54-58-64-70** fringes using 3 strands of 26 cm (10½ in) for each fringe.

– Along back and front, tie 1 fringe in each eyelet of the 1st row in Patt st, then 1 fringe in each side seam.

Secure and weave in ends.

● Abbreviation

2 special sts: 1 slipped st, k2, then pass the slipped st over those 2 sts.

● Stitches used

STOCKING STITCH (St st), using 4.5 mm needles.

PATTERN STITCH (Patt st), using 4.5 mm needles. Worked on a number of sts divisible by 3 + 1.

Row 1 (RS): k1, * yo, 2 special sts *, rep from * to *.

Row 2 and 4: P.

Row 3: * 2 special sts, yo *, rep from * to *, end with k1.

After row 4, rep from row 1.

● Tension/Gauge

To achieve a good result, it is essential to make a tension square (See "Check Your Tension" instructions at beginning of book).

20 sts and 26 rows in Patt st = 10 cm (4 in) square

● To make

BACK:

Cast on **81-89-98-107** sts. Work in St st for 2 rows.

Cont as foll until piece measures **26-27-27-28** cm (**10½-10¼-10¼-11** in) [**68-70-70-72** rows] total:

1-2-2-2 sts in St st,

PATTERN STITCH

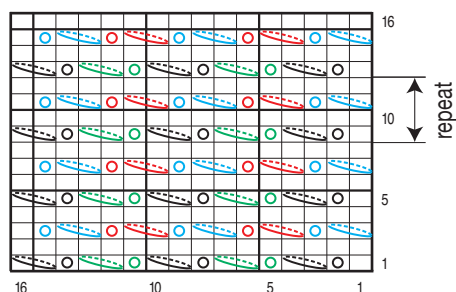

□ = 1 St st

○ or ◻ or ◻ or ◻ = 1 yo

◻ or ◻ or ◻ or ◻ = 2 special sts

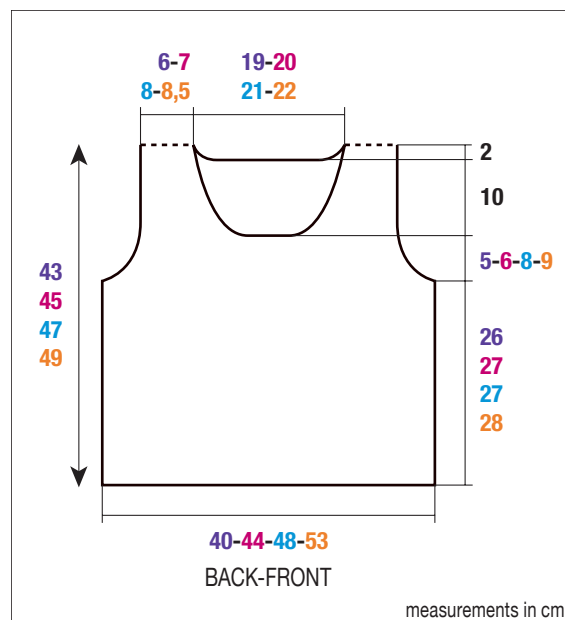

WRAP CARDIGAN



Quality:
COTON SATINÉ

Crochet hook size:
3.5 mm

Accessories:
5 meters of white double sided satin ribbon 10 mm ref. 53610 (sold as 5 meters)

One Size

Quality COTON SATINÉ	Number of balls
Blanc	35208
	11

● Abbreviations

Chain stitch = ch or ch st

Single crochet (UK: Double Crochet) = sc (uk: dc)

Slip stitch = sl st

Double crochet (UK: Treble) = dc (uk: tr)

● Stitch used

MESH STITCH (Mesh st), using 3.5 mm crochet hook. Worked on a number of sts divisible by 3 + 1 + 1.

Row 1 (RS): 1 sl st in 2nd ch, * ch4, skip 2 ch, 1 sl st in next ch *, repeat from * to *.

Row 2: ch5, 1 sl st in 1st chain-space, * ch4, 1 sl st in next chain-space *, repeat from * to *, end row with ch2, 1 dc (uk: tr) in last sl st.

Row 3: ch1, 1 sl st in the dc (uk: tr), * ch4, 1 sl st in next chain-space *, repeat from * to *.

After row 3, repeat from row 2.

Crochet basics: See "Crochet: Stitches/Techniques"

● Tension/Gauge

To achieve a good result, it is essential to make a tension square (See "Check Your Tension" instructions at beginning of book).

6 chain-spaces = 8 cm (3 in) wide

15 rows = 10 cm (4 in) high

● To make

Wrap cardigan is made in 2 parts.

1st PART:

Make a foundation chain of **71** ch. Work in Mesh st (on 1st row = **23** chain-spaces) until piece measures **130** cm (**51** in) [**196** rows] total.

Fasten off, **but** do not break yarn.

Then work one round in sc (uk: dc) as follows:

- In each corner: 5 sc (uk: dc).
- Along each longer edge: 1 sc (uk: dc) in each sl st and 2 sc (uk: dc) in each chain-space.
- Along each shorter edge: 3 sc (uk: dc) in each chain-space.

2nd PART:

Work as for 1st part.

FINISHING:

Cut ribbon in **8** equal parts (approximately **62.5** cm (**24½** in) each).

Following diagram, thread 4 ribbons along edge of each part, and stitch them in place.

Tie together ribbons A and C; B and E; D and G; F and H.

Or tie ribbons as you please to wear the wrap cardigan in a different way.

Secure and weave in ends.

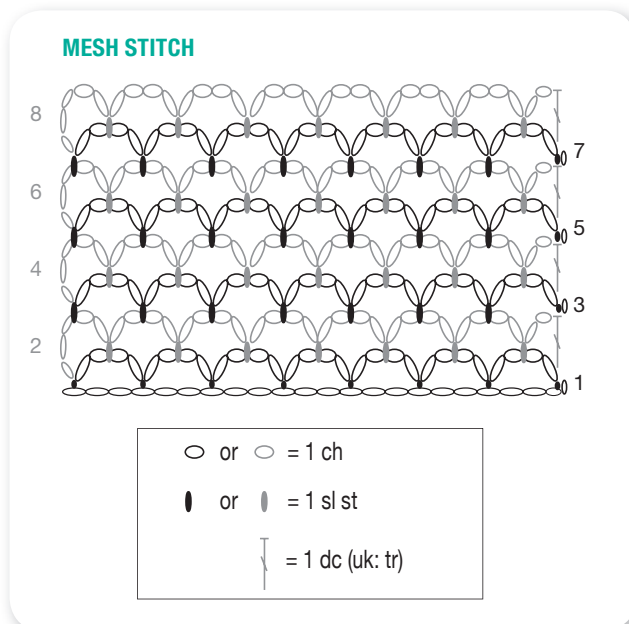

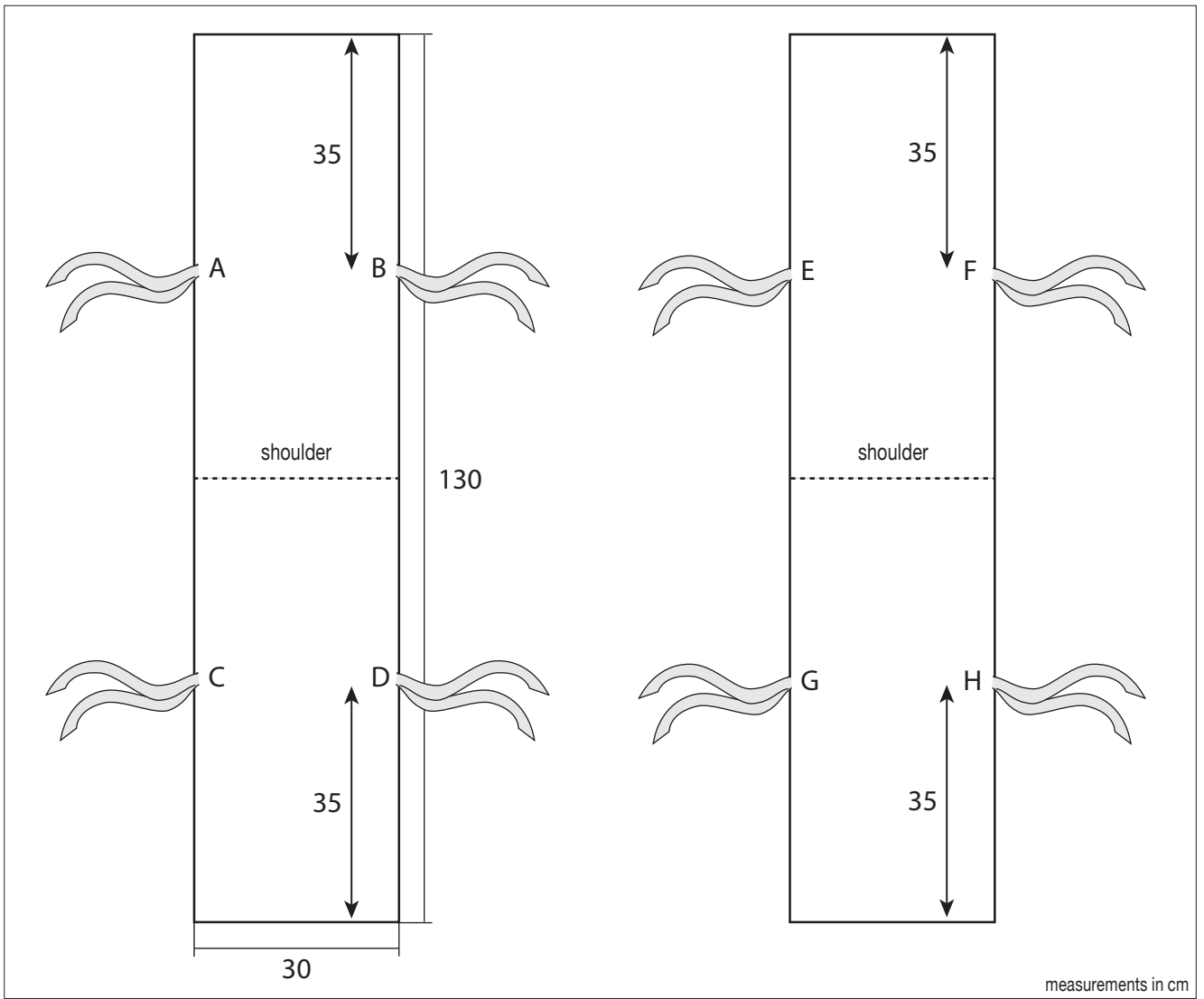

HOODED JACKET



Quality:
COTON SATINÉ

Crochet hook size:
3.5 mm

Accessories:
**Stitch markers ref. 68395
(pk of 48)**

**1 khaki separating zipper: Sizes S – M and L: 60 cm (23½ in) long ref. 50102
Sizes XL and XXL: 65 cm (25½ in) long ref. 25911**

Khaki sewing thread (not sold)

Sizes		S	M	L	XL	XXL
Quality COTON SATINÉ		Number of balls				
Kaki (A)	35242	14	16	17	19	20
Framboise (B)	35225	3	3	3	4	4
Jaune (C)	35216	3	3	3	3	3
Noir (D)	35238	2	3	3	3	3

● Abbreviations

Chain stitch = ch or ch st

Single crochet (UK: Double Crochet) = sc (uk: dc)

Double crochet (UK: Treble) = dc (uk: tr)

Slip stitch = sl st

2 Double crochet (UK: Treble) closed together = 2 dc (uk: tr) closed tog. : See “Crochet: Stitches/Techniques”.

2 Single crochet (UK: Double Crochet) closed together = 2 sc (uk: dc) closed tog: See “Crochet: Stitches/Techniques”.

● Stitches used

SINGLE CROCHET PATTERN = SC PATT (UK: DC PATT), using 3.5 mm crochet hook.

Row 1 (RS): 1 sc (uk: dc) in the 2nd ch and in each foll ch.

Row 2 and every foll row: 1 ch, 1 sc (uk: dc) in 1st sc (uk: dc) and in each foll sc (uk: dc) .

Stripes: Work as foll:

- 1 row with D.
- 1 row with A.
- 3 rows with B.
- 1 row with D.
- 1 row with A.
- 3 rows with C.

Rep those 10 rows.

DOUBLE CROCHET PATTERN = DC PATT (UK: TR PATT), using 3.5 mm crochet hook. Worked in the continuation of the Single Crochet (uk: dc).

Row 1 (RS): 3 ch (replaces the first dc (uk: tr)), 1 dc (uk: tr) in 2nd sc (uk: dc), then 1 dc (uk: tr) in each foll sc (uk: dc).

Row 2 and every foll row: 3 ch (replaces the first dc (uk: tr)), 1 dc (uk: tr) in 2nd dc (uk: tr), then 1 dc (uk: tr) in every foll dc (uk: tr).

Crochet basics: See “Crochet: Stitches/Techniques”

● Tension/Gauge

To achieve a good result, it is essential to make a tension square (See “Check Your Tension” instructions at beginning of book).

9 sc (uk: dc) and 22 rows = 10 cm (4 in) square

19 dc (uk: tr) and 10 rows = 10 cm (4 in) square

● To make

BACK:

Using D, make a foundation chain of **97-105-113-123-131** ch.

Work in striped SC patt (uk: DC patt) for **7 cm (2¾ in) [16 rows]** (= **96-104-112-122-130** sc (uk: dc)).

Cont in DC patt (uk: TR patt) with A (= **96-104-112-122-130** dc (uk: tr)) until piece measures **44-43-41-45-44 cm (17½-17-16-17¾-17½ in) [53-52-50-54-53 rows]** total.

Armholes:

Slip a stitch marker in first and last dc (uk: tr) to mark beg of armholes (see diagram) and cont in DC patt (uk: TR patt) until piece measures **64-64-64-69-69 cm (25¼-25¼-25¼-27-27 in) [73-73-73-78-78 rows]** total.

Shoulders and neck:

For shoulders dec at each end on each row:

S: 10 dc (uk: tr) twice, 11 dc (uk: tr) once,

M: 11 dc (uk: tr) twice, 12 dc (uk: tr) once,

L: 12 dc (uk: tr) twice, 13 dc (uk: tr) once,

XL: 13 dc (uk: tr) once, 14 dc (uk: tr) twice,

XXL: 14 dc (uk: tr) once, 15 dc (uk: tr) twice,

and fasten off. **34-36-38-40-42** dc (uk: tr) rem for neck.

To dec several dc (uk: tr): on right edge, work 1 sl st in each dc (uk: tr) to dec + 1, on left edge, do not work to end of row and skip the number of dc (uk: tr) to dec.

RIGHT FRONT:

Using D, make a foundation chain of **49-53-57-62-66** ch.

Work in striped SC patt (uk: DC patt) for **7 cm (2¾ in) [16 rows]** (= **48-52-56-61-65** sc (uk: dc)).

Cont in DC patt (uk: TR patt) with A (= **48-52-56-61-65** dc (uk: tr)) until piece measures **44-43-41-45-44 cm (17½-17-16-17¾-17½ in) [53-52-50-54-53 rows]** total.

Armhole:

Work as foll:

S and XXL: Slip a stitch marker in first dc (uk: tr) to mark beg of armhole.

M, L and XL: Slip a stitch marker in last dc (uk: tr) to mark beg of armhole.

Work as set until piece measures **60-60-60-65-65 cm (23½-23½-23½-25½-25½ in) [69-69-69-74-74 rows]** total.

Neck:

Work as foll:

S, M and L: Work row until **15-16-17** dc (uk: tr) rem at end of row, work 2 dc (uk: tr) closed tog, then 1 dc (uk: tr) in each of the next 2 dc (uk: tr), skip the next **11-12-13** dc (uk: tr).

XL and XXL: Work 1 sl st in each of the first **15-16** dc (uk: tr), then 3 ch (replaces the first dc (uk: tr)), 1 dc (uk: tr) in next dc (uk: tr), 2 dc (uk: tr) closed tog, then end row.

Then, dec on neck side, 2 dc (uk: tr) in from edge and **on each row 2 dc (uk: tr) twice, 1 dc (uk: tr) once.**

To dec 2 dc (uk: tr), 2 dc (uk: tr) in from edge:

At the beg of row: ch3 (replaces the 1st dc (uk: tr)), 1 dc (uk: tr) in 2nd dc (uk: tr), 2 dc (uk: tr) closed tog twice, cont row.

At the end of row: Work row until 6 dc (uk: tr) rem at end of row, work 2 dc (uk: tr) closed tog twice, then 1 dc (uk: tr) in each of the last 2 dc (uk: tr).

To dec 1 dc (uk: tr), 2 dc (uk: tr) in from edge:

At the beg of row: ch3 (replaces the 1st dc (uk: tr)), 1 dc (uk: tr) in 2nd dc (uk: tr), 2 dc (uk: tr) closed tog, cont row.

At the end of row: Work row until 4 dc (uk: tr) rem at end of row, 2 dc (uk: tr) closed tog, 1 dc (uk: tr) in each of the last 2 dc (uk: tr).

Work as set until piece measures **64-64-64-69-69** cm (**25¼-25¼-25¼-27¼-27¼** in) [**73-73-73-78-78** rows] total.

Shoulder:

Dec on armhole side as for back and fasten off.

LEFT FRONT:

Using D, make a foundation chain of **49-53-57-62-66** ch.

Work in striped SC patt (uk: DC patt) for **7** cm (**2¾** in) [**16** rows] (= **48-52-56-61-65** sc (uk: dc)).

Cont in DC patt (uk: TR patt) with A (= **48-52-56-61-65** dc (uk: tr)) until piece measures

44-43-41-45-44 cm (**17½-17-16-17¾-17½** in) [**53-52-50-54-53** rows] total.

Armhole:

Work as foll:

S and XXL: Slip a stitch marker in last dc (uk: tr) to mark beg of armhole.

M, L and XL: Slip a stitch marker in first dc (uk: tr) to mark beg of armhole.

Work as set until piece measures **60-60-60-65-65** cm (**23½-23½-23½-25½-25½** in) [**69-69-69-74-74** rows] total.

Neck:

Work as foll:

S, M and L: Work 1 sl st in each of the first **12-13-14** dc (uk: tr), then 3 ch (replaces the 1st dc (uk: tr)), 1 dc (uk: tr) in next dc (uk: tr), 2 dc (uk: tr) closed tog, then work row to end.

XL and XXL: Work row until **18-19** dc (uk: tr) rem at end of row, work 2 dc (uk: tr) closed tog, then 1 dc (uk: tr) in each of the next 2 dc (uk: tr), skip the next **14-15** dc (uk: tr).

Dec on neck side, 2 dc (uk: tr) in from edge and **on each row 2 dc (uk: tr) twice, 1 dc (uk: tr) once.**

Work as set until piece measures **64-64-64-69-69** cm (**25¼-25¼-25¼-27¼-27¼** in) [**73-73-73-78-78** rows] total.

Shoulder:

Dec on armhole side as for back and fasten off.

SLEEVES:

Using D, make a foundation chain of **49-51-53-55-57** ch.

Work in striped SC patt (uk: DC patt) for **7** cm (**2¾** in) [**16** rows] (= **48-50-52-54-56** sc (uk: dc)).

Cont in DC patt (uk: TR patt) with A (= **48-50-52-54-56** dc (uk: tr)) until piece measures **9** cm (**3½** in) [**18** rows] total.

Inc at each end, 2 dc (uk: tr) in from edge:

S: 1 dc (uk: tr) every 3rd row 9 times, 1 dc (uk: tr) every 2nd row 6 times.

M: 1 dc (uk: tr) every 3rd row 7 times, 1 dc (uk: tr) every 2nd row 9 times.

L: 1 dc (uk: tr) every 3rd row 3 times, 1 dc (uk: tr) every 2nd row 15 times.

XL: 1 dc (uk: tr) every 2nd row 19 times.

XXL: 1 dc (uk: tr) every 2nd row 20 times.

To inc 1 dc (uk: tr), 2 dc (uk: tr) in from edge: ch3 (replaces the 1st dc (uk: tr)), 1 dc (uk: tr) in 2nd dc (uk: tr), 2 dc (uk: tr) in next dc (uk: tr); cont row until 3 dc (uk: tr) rem at end of row, work 2 dc (uk: tr) in next dc (uk: tr); 1 dc (uk: tr) in each of the last 2 dc (uk: tr).

Cont on the **78-82-88-92-96** dc (uk: tr) obtained until piece measures **49** cm (**19¼** in) [**58** rows] total.

Top of sleeve:

Fasten off.

HOOD:

Using D, make a foundation chain of **143** ch.

Work in striped SC patt (uk: DC patt) (= **142** sc (uk: dc)) until piece measures **4.5-5-5.5-6-6.5** cm (**1¾-2-2¼-2¼-2½** in) [**10-11-12-13-14** rows] total.

Dec at each end, 1 sc (uk: dc) in from edge 1 sc (uk: dc) every 4th row 3 times, 1 sc (uk: dc) every 2nd row 3 times, 1 sc (uk: dc) **on each row twice.**

To dec 1 sc (uk: dc), 1 sc (uk: dc) in from edge: ch1, 1 sc (uk: dc) in 1st sc (uk: dc), 2 sc (uk: dc) closed tog, cont row until 3 sc (uk: dc) rem at end of row, 2 sc (uk: dc) closed tog, 1 sc (uk: dc) in last sc (uk: dc).



Cont on the rem **126** sc (uk: dc) until piece measures **21.5-22.5-23.5-24.5-25.5** cm (**8½-8¾-9¼-9½-10** in) [**47-49-51-53-55** rows] total.

Dec at each end on each row 2 sc (uk: dc) once, 3 sc (uk: dc) 8 times.

To dec several sc (uk: dc): on right edge, work 1 sl st in each sc (uk: dc) to dec, **on left edge**, do not work to end of row and skip the number of sc (uk: dc) to dec.

Once you have completed the last dec, fasten off. **74** sc (uk: dc) rem.

FINISHING:

Join shoulder seams.

Fold hood in 2 and sew back seam. Then sew hood to edge of neck.

Sew top of sleeves to edge of armholes, at each end of shoulder seam in between stitch markers.

Sew sleeve seams and sides of jacket.

Sew zipper with khaki sewing thread.

Secure and weave in ends.

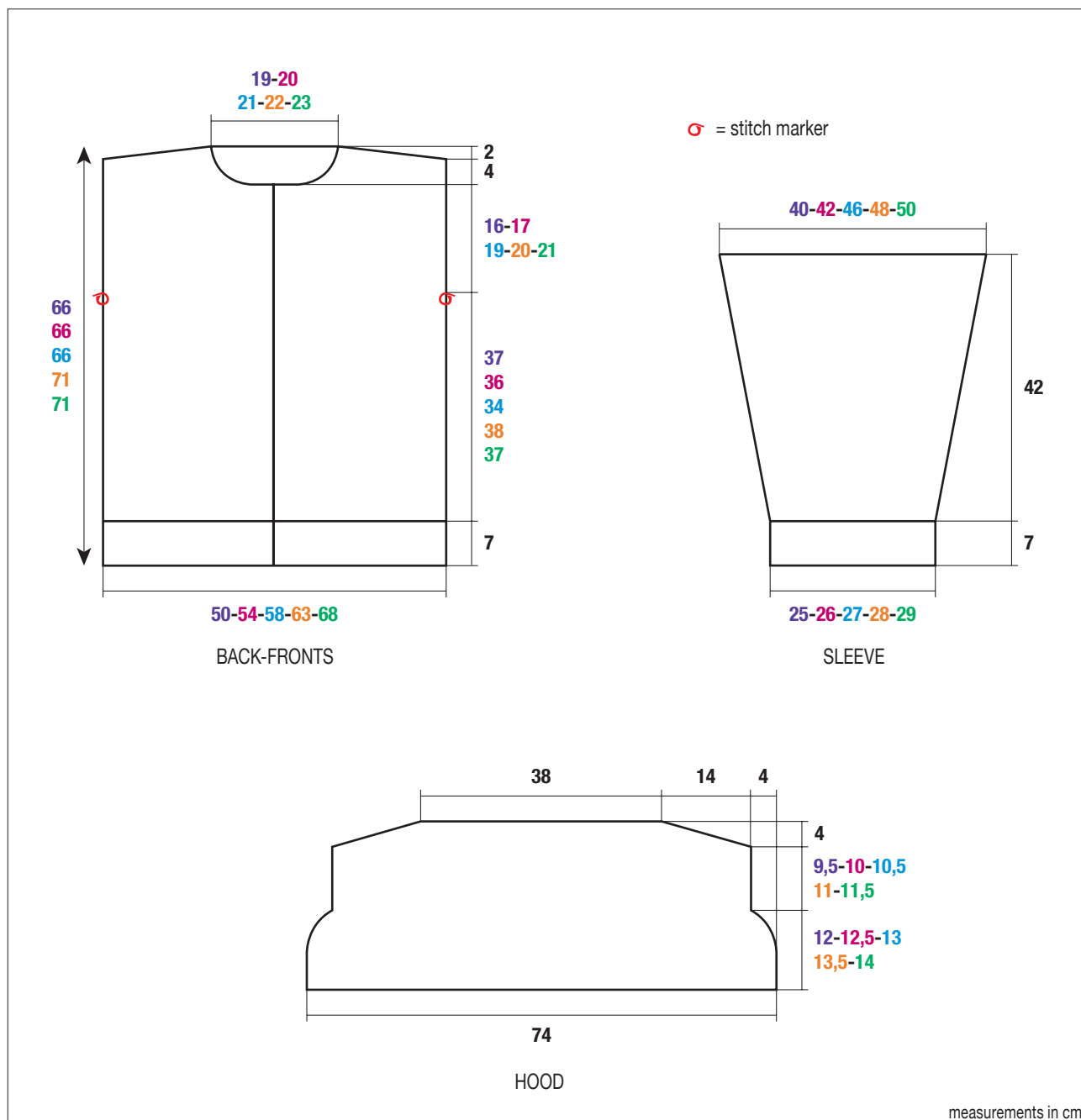

LACY SWEATER



Quality:
COTON SATINÉ

Needles:
3.5 & 4.0 mm

Sizes		S	M	L	XL
Quality COTON SATINÉ		Number of balls			
Ecru	35231	10	11	12	13

● To make

BACK:

Using 3.5 mm needles, cast on **92-98-106-114** sts.

Work in G. st for 2 rows.

Change to 4.0 mm needles and work **13-16-20-24** sts in St st, 66 sts in Lace patt, **13-16-20-24** sts in St st.

Work as set until piece measures **39-40-40-41** cm (**15¼-15½-15¾-16** in) [**102-104-104-106** rows] total.

Please note, each yo must be compensated by k2 tog or sl1, k1, pss0.

Raglan:

Cast off **5-5-5-6** sts at the beg of the next 2 rows.

Then cont and work the first 3 and last 3 sts in St st and dec, 2 sts in from edge starting on 1st row then every 2nd row:

S: 2 sts once, 1 st 23 times.

M: 2 sts twice, 1 st 23 times.

L: 2 sts twice, 1 st 26 times.

XL: 2 sts 3 times, 1 st 26 times.

To dec 2 sts, 2 sts in from edge: k2, k3 tog, cont row until 5 sts rem on left needle, sl1, k2 tog, pss0, k2.

To dec 1 st, 2 sts in from edge: k2, k2 tog, cont row until 4 sts rem on left needle, sl1, k1, pss0, k2.

Once you have completed the last raglan dec, work even for 1 row on the rem **32-34-36-38** sts and cast off all sts for neck.

FRONT:

Using 3.5 mm needles, cast on **92-98-106-114** sts.

Work in G. st for 2 rows.

Change to 4.0 mm needles and work **13-16-20-24** sts in St st, 66 sts in Lace patt, **13-16-20-24** sts in St st.

Work as set until piece measures **39-40-40-41** cm (**15¼-15½-15¾-16** in) [**102-104-104-106** rows] total.

Raglan and neck:

Cast off **5-5-5-6** sts at the beg of the next 2 rows for raglan.

Then cont and work the first 3 and last 3 sts in St st and dec, 2 sts in from edge on 1st row then every 2nd row:

S: 2 sts once, 1 st 19 times,

M: 2 sts twice, 1 st 19 times,

L: 2 sts twice, 1 st 22 times,

● Stitches used

GARTER STITCH (G. st), using 3.5 mm needles.

STOCKING STITCH (St st), using 4.0 mm needles.

REVERSE STOCKING STITCH (Rev St st), using 4.0 mm needles.

LACE PATTERN (LACE PATT), using 4.0 mm needles. Worked on a number of sts divisible by 13 + 1.

Row 1, 3 and 5 (RS): p1, * k2 tog, k3, yo, k2 tbl, yo, k3, sl1, k1, pss0, p1 *, rep from * to *.

Row 2 and all even rows: k1, * p5, p2 tbl, p5, k1 *, rep from * to *.

Row 7: p1, * k2 tog, k2, yo, k1, k2 tbl, k1, yo, k2, sl1, k1, pss0, p1 *, rep from * to *.

Row 9: p1, * k2 tog, k1, yo, k2 tog, yo, k2 tbl, yo, sl1, k1, pss0, yo, k1, sl1, k1, pss0, p1 *, rep from * to *.

Row 11: p1, * k2 tog, yo, k1, k2 tog, yo, k2 tbl, yo, sl1, k1, pss0, k1, yo, sl1, k1, pss0, p1 *, rep from * to *.

Row 13: p1, * k2 tog, k1, yo, k2, k2 tbl, k2, yo, k1, sl1, k1, pss0, p1 *, rep from * to *.

Row 15: p1, * k2 tog, k2, yo, k1, k2 tbl, k1, yo, k2, sl1, k1, pss0, p1 *, rep from * to *.

After row 16, rep from row 1.

PATTERNED 2/2 RIB (Patt 2/2 Rib), using 3.5 mm needles. Worked on a number of sts divisible by 4 + 2.

Row 1 (RS): k2 tbl, * p2, k2 tbl *, rep from * to *.

Row 2: p2 tbl, * k2, p2 tbl *, rep from * to *.

Rep those 2 rows.

● Tension/Gauge

To achieve a good result, it is essential to make a tension square (See "Check Your Tension" instructions at beginning of book).

21 sts and 26 rows in St st = 10 cm (4 in) square

19.5 sts and 26 rows in Lace patt = 10 cm (4 in) square

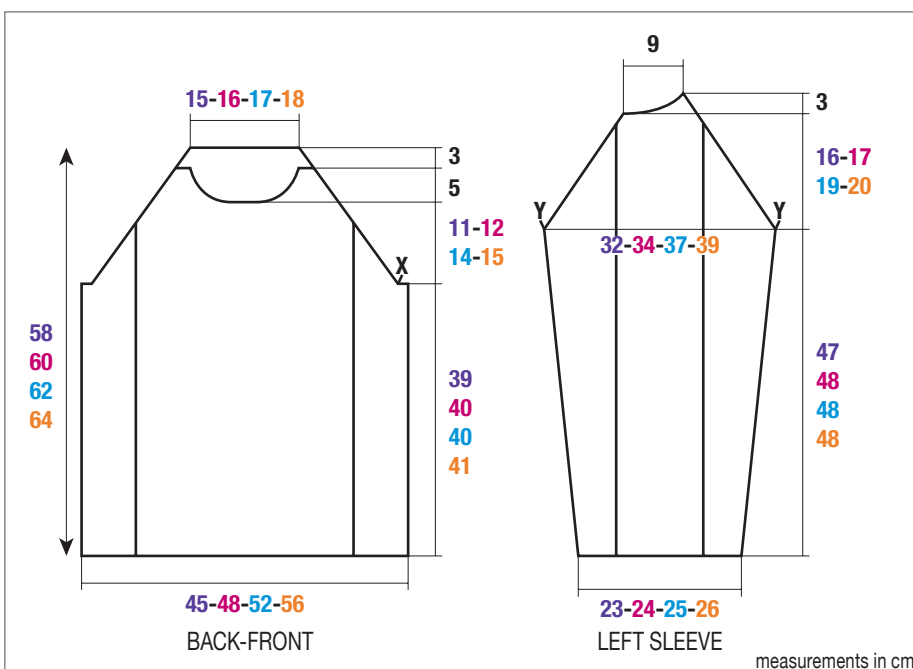

XL: 2 sts 3 times, 1 st 22 times,

but meanwhile, when work measures **50-52-54-56** cm (**19¼-20½-21¼-22** in) [**130-134-140-144** rows] total, for neck cast off the **14-16-18-20** center sts.

Then cont each side separately and cast off on neck side every 2nd row 3 sts once, 2 sts once, 1 st 4 times and the rem 4 sts.

LEFT SLEEVE:

Using 3.5 mm needles, cast on **47-49-51-53** sts.

Work in G. st for 2 rows.

Change to 4.0 mm needles and work **10-11-12-13** sts in St st, 27 sts in Lace patt, **10-11-12-13** sts in St st.

Work as set until piece measures **4.5** cm (**1¾** in) [**12** rows] total.

Inc at each end, 2 sts in from edge:

S: 1 st every 12th row 5 times, 1 st every 10th row 5 times.

M: 1 st every 10th row 11 times.

L: 1 st every 10th row 4 times, 1 st every 8th row 9 times.

XL: 1 st every 8th row 14 times.

Cont on the **67-71-77-81** sts obtained until piece measures **47-48-48-48** cm (**18½-19-19-19** in) [**122-124-124-124** rows] total.

Raglan:

Cast off at each end **1-1-1-2** sts, then dec, 2 sts in from edge on right edge as for back, at the same time on left edge as for front.

Then cast off on left edge every 2nd row 9 sts once, 3 sts once, 2 sts once, 1 st once and the rem 4 sts.

RIGHT SLEEVE:

Work as left sleeve, reversing shaping of raglan.

COLLAR:

Using 3.5 mm needles, cast on **110-114-118-122** sts.

Work in Patt 2/2 Rib for 6 rows and leave all sts on hold.

FINISHING:

Join raglans, so as to match points X and Y (see diagram).

Graft collar to neck edge (see Grafting a border instructions) and join the shorter ends of collar.

Sew sleeve seams and sides of sweater.

Secure and weave in ends.

Please note, each yo must be compensated by k2 tog or sl1, k1, pss0.

LACE PATTERN

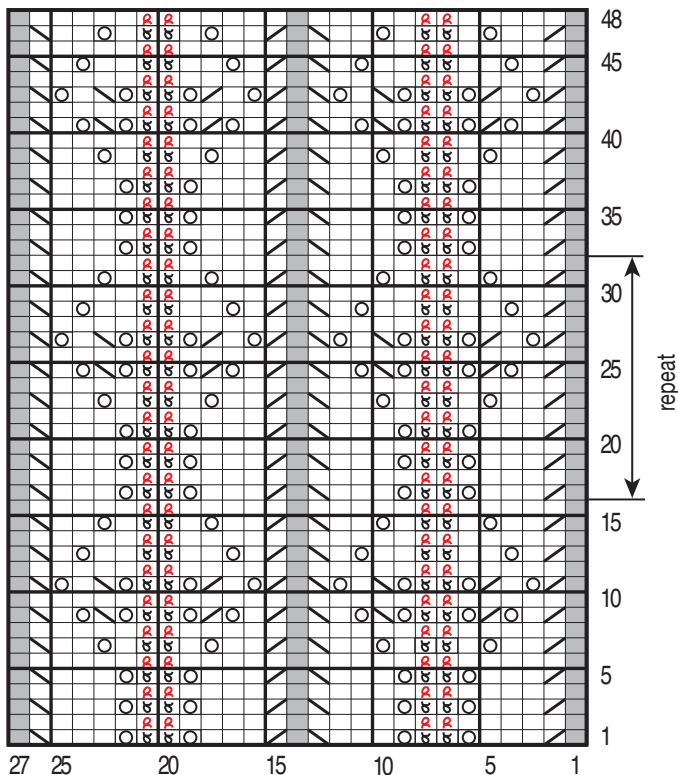

■	= 1 Rev St st
□	= 1 St st
▨	= k2 tog
▩	= sl1, k1, pss0
⊠	= yo
⊞	= k1 tbl
⊠	= p1 tbl



Quality:
COTON SATINÉ

Needles:
4.0 mm- 1 cable needle (CN)
Crochet hook size:
3.5 mm

Accessories
Stitch markers ref. 68395 (pk of 48)
1 black non separating zipper 22 cm (8½ in) ref. 43716

Sizes		S	M	L	XL
Quality COTON SATINÉ		Number of balls			
Gris (A)	35227	2	3	3	3
Noir (B)	35238	2	2	2	2
Fushia (C)	35205	1	1	2	2

● Abbreviations

Right cross = CR

Left cross = CL

12CR: Slip 6 sts to CN at back of work, k the next 6 sts, then k the 6 sts from CN.

12CL: Slip 6 sts to CN in front of work, k the next 6 sts, then k the 6 sts from CN.

● Stitches used

STOCKING STITCH (St st) and REVERSE STOCKING STITCH (Rev St st), using 4.0 mm needles.

SEED STITCH (Seed st), using 4.0 mm needles.

CABLE, using 4.0 mm needles. Worked over 18 sts.

Row 1 and 3 (RS): k.

Row 2 and all even rows: p.

Row 5: 12CR, k6.

Row 7 and 9: k.

Row 11: k6, 12CL.

After row 12, rep from row 1.

Crochet basics: See "Crochet: Stitches/Techniques"

● Tension/Gauge

To achieve a good result, it is essential to make a tension square (See "Check Your Tension" instructions at beginning of book).

21 sts and 26 rows in St st = 10 cm (4 in) square.

● To make

Top is made in 4 parts. Arrows on diagram show direction of work.

1st PART:

Using A, cast on **22-24-26-26** sts.

Work even in St st until piece measures **72-80-88-98** cm (**28¼-31½-34½-28½** in) [**188-208-228-254** rows].

Cast off all sts.

2nd PART:

Using C, cast on **14** sts. Work even in St st until piece measures **72-80-88-98** cm (**28¼-31½-34½-28½** in) [**188-208-228-254** rows].

Cast off all sts.

3rd PART:

Using B, cast on **27-29-31-35** sts. Work even in St st until piece measures **4.5-6-7.5-6** cm (**1¼-2¼-3-2¼** in) [**12-16-20-16** rows].

Cont and work short rows, **as foll:**

Work **14-15-16-18** sts, turn work.

Slip 1 st and work row to end.

* Work **24-26-28-32** rows on all sts.

Work **14-15-16-18** sts, turn.

Slip 1 st and work row to end *.

Rep from * to *.

But:

- When work measures **31-34-37-41** cm (**12¼-13¼-14½-16** in) [**80-88-96-106** rows] total measured on right edge, slip a stitch marker in first st to mark **the beg of arm opening**.

- When work measures **49-54-59-65** cm (**19¼-21¼-23¼-25½** in) [**128-140-152-168** rows] total measured on right edge, slip a stitch marker in first st to mark **the end of arm opening**.

Work as set until piece measures **78-86-94-104** cm (**30¼-33¼-37-41** in) [**204-224-244-270** rows] total measured on right edge.

Cast off all sts.

4th PART:

Using A, cast on **30** sts.

Work:

3 sts in Seed st,

1 st in Rev St st,

18 cable sts,

2 sts in Rev St st,

6 sts in St st.

Work as set until piece measures **31-34-37-41** cm (**12¼-13¼-14½-16** in) [**80-88-96-106** rows].

Slip a stitch marker in last st to mark the beg of arm opening.

Work as set until piece measures **56-65-71-79** cm (**22-25½-28-31** in) [**146-168-184-206** rows] total.

Slip a stitch marker in last st to mark the end of arm opening.

Work as set until piece measures **85-97-106-118** cm (**33½-38¼-41¼-46½** in) [**222-252-276-306** rows] total.

Cast off all sts.

STRAP:

Using B, make a foundation chain of **81-85-93-97** ch.

Work 1 sc (uk: dc) in 2nd ch, then 1 sc (uk: dc) in each foll ch (= **80-84-92-96** sc (uk: dc)) and fasten off.

Change to C and work as foll:

- work 1 sl st in **33rd-35th-39th-41th** sc (uk: dc) in B (counted from beg of row in sc (uk: dc)), then make a foundation chain of **34-36-40-42** ch.

- Work 1 sc (uk: dc) in 2nd ch, then 1 sc (uk: dc) in each ch, 1 sc (uk: dc) in the sl st, then 1 sc (uk: dc) in each of the rem **47-49-53-55** sc (uk: dc) in B.

Fasten off.

FINISHING:

Assemble foll diagram:

- 1st part along edge of 2nd part.

- then the 2nd part along edge of 3rd part.

- then 3rd part along edge of 4th part.

- Attach strap.

Join shorter ends of 4th part.

Attach zipper along **22 cm (8½ in)** (= red line on diagram) placing the zip towards bottom of top.

Secure and weave in ends.

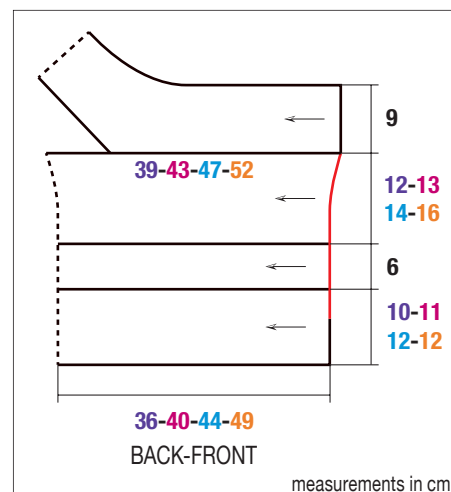

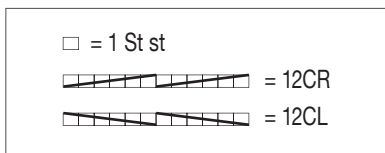
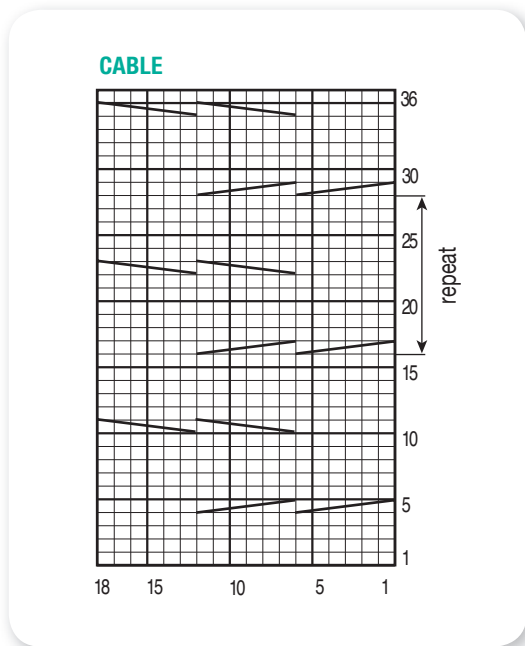
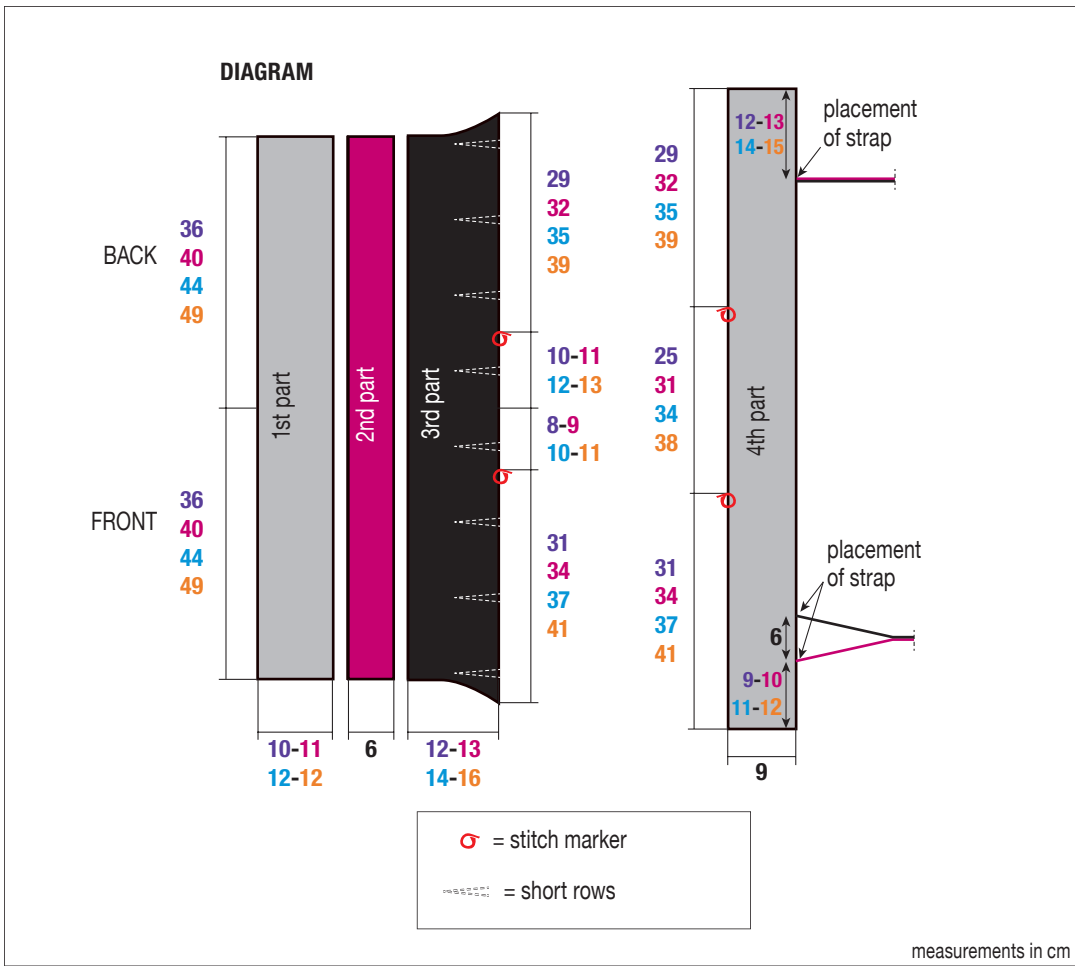

SLEEVELESS TOP



Quality:
COTON SATINÉ

Sizes		4 yrs	6 yrs	8 yrs	10 yrs	12 yrs
Quality COTON SATINÉ		Number of balls				
Rouge	35219	3	4	4	5	6

Needles:
5.5 mm
1 tapestry needle
(for seams and to weave in ends)

Accessories:
Stitch markers ref. 68395 (pk of 48)

● Stitch used

GARTER STITCH (G. st), using 5.5 mm needles.
K all rows.

● Tension/Gauge

To achieve a good result, it is essential to make a tension square (See “Check Your Tension” instructions at beginning of book).

17 sts and 26 rows in G. st = 10 cm (4 in) square

● To make

As G. st is reversible, mark the RS on 1st row with scrap yarn.

BACK:

Using 5.5 mm needles, cast on **52-58-62-67-73** sts.

Work even in G. st until piece measures **23-26-29-32-35** cm (**9-10½-11½-12½-13¾** in) [**60-68-76-82-90** rows] total.

Armholes:

Slip a stitch marker in first and last st to mark **beginning of armholes** (see diagram) and continue in G. st until piece measures **35-39-43-47-51** cm (**13¾-15¼-17-18½-20** in) [**92-102-112-122-132** rows] total.

Shoulders and neck:

Cast off all sts (See “Beginner’s Notes”) and cut yarn, leaving a **30 cm (12 in)** end. This yarn end will be used for seams.

FRONT:

Work as for back.

FINISHING:

Overlap back and front, with RS together. Join **shoulders** along **11-13-14-16-17** sts at each end using a backstitched seam (See “Beginner’s Notes”) and leave free the **30-32-34-35-37** center sts **for neck**.

Join both sides of top (= **red** lines on diagram) using a backstitched seam. Leaving free the armholes in between stitch markers, and **8 cm (3 in)** (= **blue** lines on diagram) along bottom of body for side slits.

Weave in ends:

Using tapestry needle, weave in the cut ends through several sts and cut excess (See “Beginner’s Notes”).

Turn top inside out so that the RS is visible.

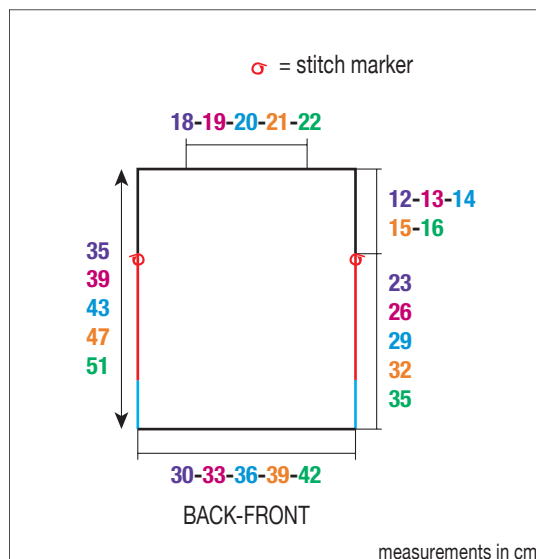

KNIT OVERALLS



Quality:
COTON SATINÉ

Needles:
3.5 & 4.0 mm

Accessories:
90 cm (35½ in) of red gros grain ribbon 10 mm ref. 30926 (sold per 1 meter unit)
5 see-through press studs Ø 10 mm ref. 60467 (pk of 59 matching ones)

Sizes		1 mth	3 mths	6 mths	12 mths
Quality COTON SATINÉ		Number of balls			
Framboise	35225	2	3	3	4

Stitches used

GARTER STITCH (G. st), using 3.5 mm needles.
K all rows.

STOCKING STITCH (St st), using 4.0 mm needles.

Row 1: k

Row 2: p

Tension/Gauge

To achieve a good result, it is essential to make a tension square (See “Check Your Tension” instructions at beginning of book).

21 sts and 26 rows in St st = 10 cm (4 in) square

To make

BACK:

Left leg:

Using 3.5 mm needles, cast on **22-24-26-28** sts.

Work straight in G. st for **4** rows.

Change to 4.0 mm needles and work as follows:
4 sts in G. st for edging, **18-20-22-24** sts in St st.

Work as set until piece measures **2.5 cm (1 in) [8 rows]** total.

Increase on right edge, **4** sts in from edge (work the increased sts in St st):

1 month: 1 st every 4th row 4 times, 1 st every 2nd row 3 times.

3 months: 1 st every 4th row 5 times, 1 st every 2nd row twice.

6 months and 12 months: 1 st every 4th row 7 times.

Once you have worked the last increase, work as set for **1-1-1-3** rows on the **29-31-33-35** sts obtained.

Then leave all sts on hold.

Right leg:

Using 3.5 mm needles, cast on **22-24-26-28** sts.

Work straight in G. st for **4** rows.

Change to 4.0 mm needles and work as follows:
18-20-22-24 sts in St st, **4** sts in G. st for border.

Work as set until piece measures **2.5 cm (1 in) [8 rows]** total.

Increase on left edge as for left leg.

Once you have completed the last increase, work as set for **1-1-1-3** rows on the **29-31-33-35** sts obtained.

Then leave all sts on hold.

Start body:

Place back on one needle the sts from both legs and work as follows:

k **25-27-29-31** sts,
k 2 sts together twice,
cast on 2 extra sts,
k 2 sts together twice,
k **25-27-29-31** sts.

P 1 row on the **56-60-64-68** sts obtained.

Then continue in St st until piece measures **11.5-12.5-13.5-14.5 cm (4½-5-5¼-5¾ in) [32-34-38-40 rows]** total.

Decrease at each end, 2 sts in from edge:

1 month: 1 st every 6th row 5 times, 1 st every 4th row 3 times.

3 months: 1 st every 6th row 8 times.

6 months: 1 st every 8th row 6 times, 1 st every 6th row twice.

12 months: 1 st every 8th row 8 times.

To decrease 1 st, 2 sts in from edge: k 2, k 2 sts together, continue row until 4 sts remain on left needle, slip 1 st, k1, pass slipped st over, k 2.

Continue on the remaining **40-44-48-52** sts until piece measures **28-32-36-40 cm (11-12½-14-15¾ in) [74-84-96-106 rows]** total.

Slanted edge of armholes:

Cast off **5-6-6-6** sts at the beginning of the next 2 rows.

Then decrease, 3 sts in from edge starting on 1st row, then every 2nd row:

1 month and 3 months: 1 st 4 times.

6 months: 1 st 5 times.

12 months: 1 st 6 times.

To decrease 1 st, 3 sts in from edge: k 3, k 2 sts together, continue row until 5 sts remain on left needle, slip 1 st, k1, pass slipped st over, k 3.

Once you have worked the last slanted decrease, work even for **3** rows on the remaining **22-24-26-28** sts.

Then p 1 row on RS for fold.

Work another **3** rows in St st and cast off all sts.

FRONT:

Work as for back.

FINISHING:

Sew side seams of overalls.

Hem: Fold top of back and front over 1cm (½ in) to WS and stitch hem in place, leaving the shorter ends free.

Ribbon: Cut 2 lengths of ribbon measuring each 45 cm (17¾ in). Thread a ribbon through each hem and tie on shoulders.

Press studs: Sew press studs in place (see placement on diagram).

Secure and weave in ends.

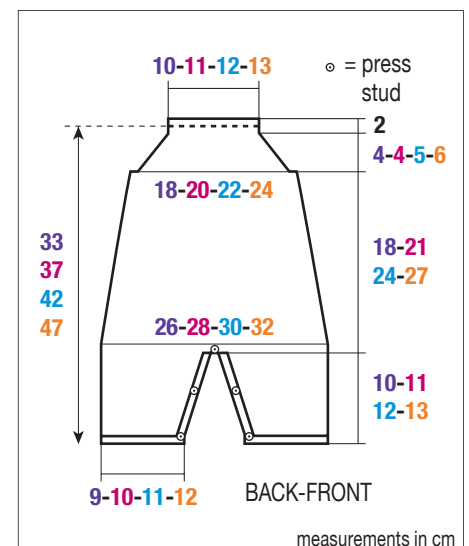

VEST



Quality:
COTON SATINÉ

Needles:
3.5 & 4.0 mm

Sizes		4 yrs	6 yrs	8 yrs	10 yrs	12 yrs
Quality COTON SATINÉ		Number of balls				
Turquoise (A)	35236	3	3	4	4	5
Marine (B)	35203	1	1	1	1	1

● **Stitch used**

STOCKING STITCH (St st), using 3.5 and 4.0 mm needles.

● **Tension/Gauge**

To achieve a good result, it is essential to make a tension square (See "Check Your Tension" instructions at beginning of book).

21 sts and 26 rows in St st = 10 cm (4 in) square

● **To make**

BACK:

Using 3.5 mm needles and A, cast on **65-71-77-83-89** sts.

Work even in St st as foll:

- 4 rows using 3.5 mm needles,
- then change to 4.0 mm needles and cont until piece measures **23-26-29-32-35** cm (**9-10½-11½-12½-13¾** in) [**60-68-76-84-92** rows] total.

Armholes:

Cast off at each end, every 2nd row as foll (1-st dec are worked 2 sts in from edge):

4 years: 3 sts once, 2 sts once, 1 st 4 times.

6 years: 3 sts once, 2 sts once, 1 st 5 times.

8 years, 10 years and 12 years: 3 sts once, 2 sts twice, 1 st 4 times.

To dec 1 st, 2 sts in from edge: k2, k2 tog, cont row until 4 sts rem on left needle, sl1, k1, pssso, k2.

Cont on the rem **47-51-55-61-67** sts until piece measures **36-40-44-48-52** cm (**14-15¾-17½-19-20½** in) [**94-106-116-126-136** rows] total.

Shoulders and neck:

For shoulders cast off at the beg of every row as foll:

4 years: 3 sts 8 times,

6 years: 3 sts 6 times, 4 sts twice,

8 years: 3 sts 4 times, 4 sts 4 times,

10 years: 4 sts 8 times,

12 years: 4 sts 4 times, 5 sts 4 times,

at the same time when working 1st shoulder dec, for neck cast off the **13-15-17-19-21** center sts.

Cont each side separately and cast off on neck side every 2nd row: 3 sts once, 2 sts once.

FRONT:

Using 3.5 mm needles and B, cast on **65-71-77-83-89** sts.

Work in St st as foll:

- 4 rows using 3.5 mm needles,
- then change to 4.0 mm needles and cont foll chart according to size made. Make sure you cross yarns when changing color.

Armholes:

Cast off as for back.

Cont on the rem **47-51-55-61-67** sts until piece measures **31-35-39-42-46** cm (**12¼-13¾-15¼-16½-18** in) [**80-92-102-110-120** rows] total.

Neck:

Cast off the **7-9-11-13-15** center sts.

Cont each side separately and cast off on neck side:

4 years, 6 years and 8 years: every 2nd row 3 sts once, 2 sts once, 1 st 3 times.

10 years and 12 years: every 2nd row 3 sts once, 2 sts once, 1 st once ; then every 4th row 1 st twice.

Shoulders:

Cast off as for back.

FINISHING:

Join right shoulder.

Neck border: Using 3.5 mm needles and A, pick up and k **79-83-87-95-99** sts along neck edge.

Work in St st for **2** rows, then cast off all sts kwise on WS.

Join left shoulder, and the shorter ends of edging.

Armhole borders: Using 3.5 mm needles and A, pick up and k **66-72-78-84-92** sts along edge of each armhole. Work in St st for **2** rows, then cast off all sts kwise on WS.

Sew side seams of vest.

Secure and weave in ends.

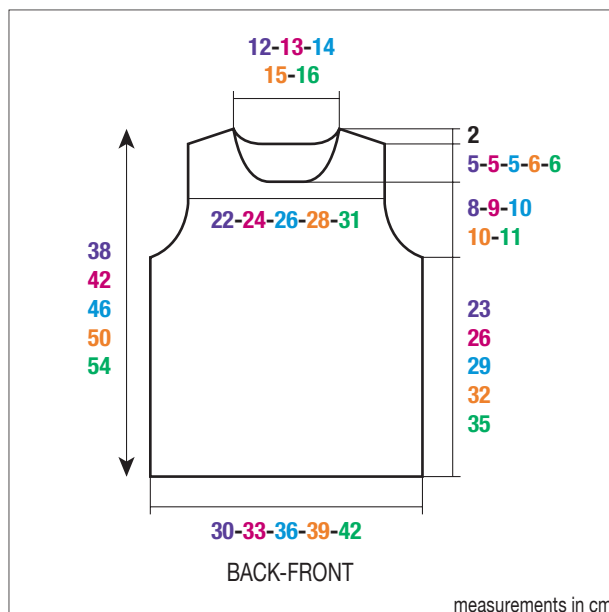

FRONT

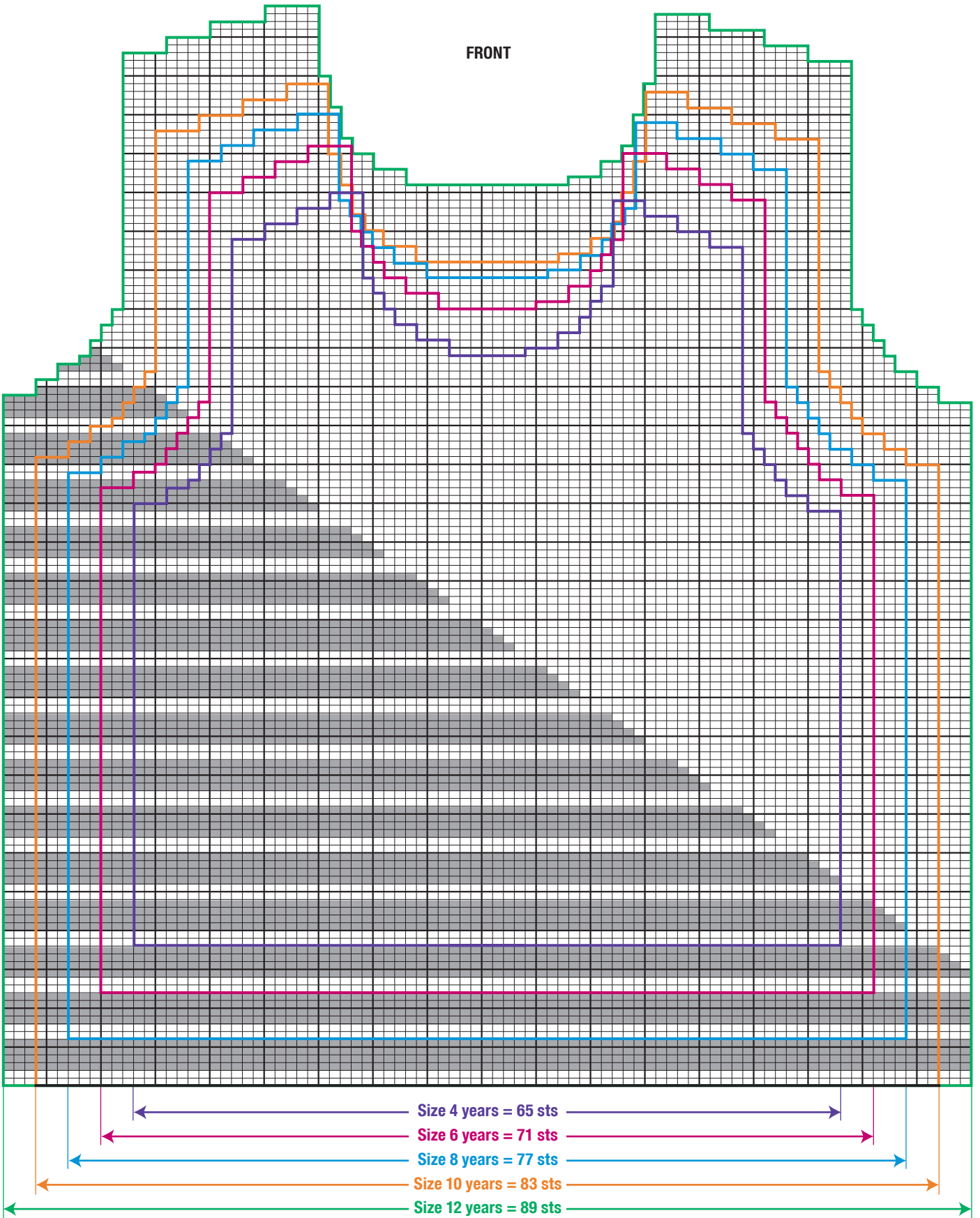

HOODED JACKET



Quality:
COTON SATINÉ

Needles:
3.5 & 4.0 mm



Accessories:

1 ecru thin separating zipper: size 3 months - 20 cm (8 in) long ref. 67961
size 6 months - 25 cm (10 in) long ref. 67966
sizes 12 months, 18 months and 24 months - 30 cm (12 in) long ref. 67974

Sizes		3 mths	6 mths	12 mths	18 mths	24 mths
Quality COTON SATINÉ		Number of balls				
Beige (A)	35214	3	4	4	5	5
Paille (B)	35199	1	1	1	1	1

Stitches used

STRIPED GARTER STITCH (Striped G. st), using 3.5 mm needles.

K all rows.

Work 2 rows with A, 2 rows with B, 2 rows with A, 2 rows with B.

STOCKING STITCH (St st), using 4.0 mm needles.

Row 1: k

Row 2: p

Stripes: Work 2 rows with A, 1 row with B. Repeat those 3 rows. Work with 2 different balls of A to avoid cutting yarn after each stripe.

Tension/Gauge

To achieve a good result, it is essential to make a tension square (See "Check Your Tension" instructions at beginning of book).

21 sts and 26 rows in St st = 10 cm (4 in) square

To make

BACK:

Using 3.5 mm needles and A, cast on **52-56-60-64-66** sts.

Work in striped G. st for **2 cm (¾ in) [8 rows]**.

Change to 4.0 mm needles and using A, work in St st until piece measures **13-17-21-20.5-20** cm (**5-6¼-8¼-8-8** in) [**36-46-58-56-54** rows] total.

Armholes:

Cast off 2 sts at the beginning of the next 2 rows.

Continue on the remaining **48-52-56-60-62** sts until piece measures **23-28-33-33-33** cm (**9-11-13-13-13** in) [**62-74-88-88-88** rows] total.

Shoulders and neck:

Cast off at the beginning of every row as follows:

3 months: 4 sts twice, 5 sts twice and the remaining 30 sts (= 5 sts at each end for shoulders and 20 sts for neck).

6 months: 5 sts 4 times and the remaining 32 sts (= 5 sts at each end for shoulders and 22 sts for neck).

12 months: 5 sts 4 times and the remaining 36 sts (= 6 sts at each end for shoulders and 24 sts for neck).

18 months: 5 sts twice, 6 sts twice and the remaining 38 sts (= 6 sts at each end for shoulders and 26 sts for neck).

24 months: 6 sts 4 times and the remaining 38 sts (= 6 sts at each end for shoulders and 26 sts for neck).

LEFT FRONT:

Using 3.5 mm needles and A, cast on **26-28-30-32-33** sts.

Work in striped G. st for **2 cm (¾ in) [8 rows]**.

Change to 4.0 mm needles, using A work in St st.

Armhole:

Cast off on right edge as for back.

Continue on the remaining **24-26-28-30-31** sts until piece measures **20-25-30-30-30** cm (**8-10-12-12-12** in) [**54-66-80-80-80** rows] total.

Neck:

Cast off on left edge every 2nd row **6-7-8-9-9** sts once, 2 sts once, 1 st twice.

Work even until piece measures **23-28-33-33-33** cm (**9-11-13-13-13** in) [**62-74-88-88-88** rows] total.

Shoulder:

Cast off on right edge every 2nd row:

3 months: 4 sts once, 5 sts twice.

6 months: 5 sts 3 times.

12 months: 5 sts twice, 6 sts once.

18 months: 5 sts once, 6 sts twice.

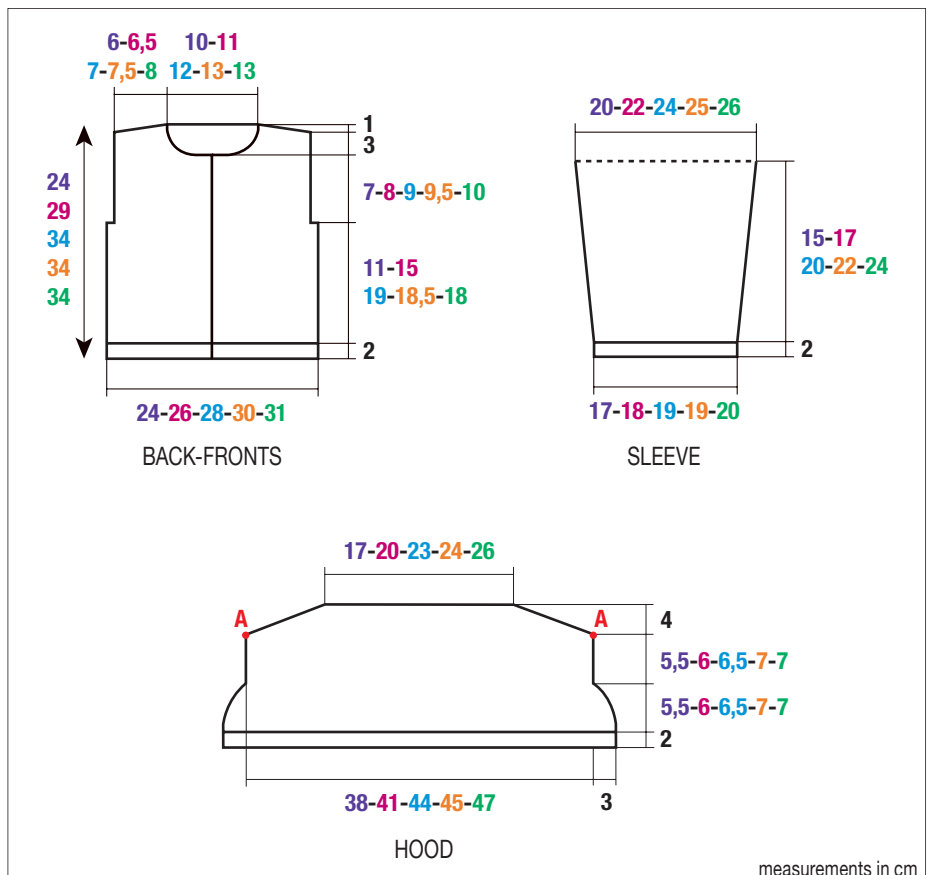

24 months: 6 sts 3 times.

RIGHT FRONT:

Using 3.5 mm needles and A, cast on **26-28-30-32-33** sts.

Work in striped G. st for **2 cm (¾ in) [8 rows]**.

Change to 4.0 mm needles, using A work in St st.

Armhole:

Cast off on left edge as for back.

Continue on the remaining **24-26-28-30-31** sts.

Neck:

Cast off on right edge as for left front.

Shoulder:

Cast off on left edge as for left front.

SLEEVES:

Using 3.5 mm needles and A, cast on **38-40-42-42-44** sts.

Work in striped G. st for **2 cm (¾ in) [8 rows]**.

Change to 4.0 mm needles and using A, work in St st until piece measures **6 cm (2¼ in) [18 rows]** total.

Increase at each end, 2 sts in from edge:

3 months: 1 st 3 times every 8th row.

6 months: 1 st 4 times every 8th row.

12 months: 1 st 5 times every 8th row.

18 months: 1 st 4 times every 8th row, twice 1 st every 6th row.

24 months: 1 st 6 times every 8th row.

Continue on the **44-48-52-54-56** sts obtained until piece measures **17-19-22-24-26 cm (6¾-7½-8½-9½-10½ in) [46-52-60-66-70 rows]** total.

Top of sleeve:

Leave all sts on hold.

HOOD:

Using 3.5 mm needles and A, cast on **94-100-106-108-112** sts.

Work in striped G. st for **2 cm (¾ in) [8 rows]**.

Change to 4.0 mm needles, continue in striped G. st and cast off at each end as follows:

3 months: starting on 5th row, then every 2nd row 1 st 4 times, 2 sts once.

6 months and 12 months: starting on 5th row, then every 4th row 1 st twice; then every 2nd row 1 st twice, 2 sts once.

18 months and 24 months: starting on 7th row, then every 4th row 1 st twice; then every 2nd row 1 st twice, 2 sts once.

Continue on the remaining **82-88-94-96-100** sts until piece measures **13-14-15-16-16 cm (5-5½-6-6¼-6¼ in) [36-40-42-44-44 rows]** total.

Cast off at the beginning of every row as follows: 4 sts 6 times, 5 sts 4 times and the remaining **38-44-50-52-56** sts.

FINISHING:

Join the **14-15-16-17-18** sts of shoulders.

Fold hood in 2 and sew back seam in order to match points A (see diagram).

Sew hood along neck edge.

Graft top of sleeves to vertical section of armholes (see Grafting instructions).

Sew sleeve seams and sides of jacket.

Attach zipper.

Secure and weave in ends.

SUMMER DRESS



Quality:
COTON SATINÉ

Needles:
4.0 mm



Accessories:
2 pearly square buttons 10 mm ref. 42513 (pk of 6)

Sizes		3 mths	6 mths	12 mths	24 mths
Quality COTON SATINÉ		Number of balls			
Paille (A)	35199	2	2	3	3
Blanc (B)	35208	1	1	1	1

Stitches used

SEED STITCH (Seed st), using 4.0 mm needles.

Row 1: *k1, p1*, rep from * to *.

Row 2: p over k, k over p.

STOCKING STITCH (St st), using 4.0 mm needles.

Row 1: k

Row 2: p

Tension/Gauge

To achieve a good result, it is essential to make a tension square (See "Check Your Tension" instructions at beginning of book).

21 sts and 32 rows in Seed st = 10 cm (4 in) square

21 sts and 26 rows in St st = 10 cm (4 in) square

To make

BACK:

Using A, cast on **59-65-71-77** sts.

Work in Seed st for **4** rows.

Continue in St st as follows:

2 rows with A,

* **4** rows with B, **4** rows with A *, repeat from * to *.

Work as set until piece measures **19-22-25-28** cm (**7½-8½-10-11** in) [**50-58-66-74** rows] total, ending with a stripe in B.

Continue with A on all sts until piece measures approximately **20-23-26-29** cm (**8-9-10½-11½** in) [**53-61-69-77** rows] total.

Work as follows on WS:

p **4-3-2-2** sts, **p3 together**, * p **4** sts, **p3 together** *, work **7-8-9-10** times total from * to *, then p **3-3-3-2** sts.

Continue in Seed st on the remaining **43-47-51-55** sts until piece measures **21-24-27-30** cm (**8¼-9½-10¾-12** in) [**58-66-74-82** rows] total.

Slanted edges of armholes:

Cast off **4-5-6-7** sts at the beginning of the next 2 rows.

Then decrease as follows, 3 sts in from edge:

3 months: starting on 3rd row, then every 4th row 2 sts 3 times.

6 months: starting on 3rd row, then every 6th row 2 sts 3 times.

12 months: starting on 5th row, then every 6th row 2 sts 3 times.

24 months: starting on 7th row, then every 6th row 2 sts 3 times.

To decrease 2 sts, 3 sts in from edge: Work 3 sts in Seed st, k3 together or p3 together, continue row until 6 sts remain on left needle, (slip 1 st, k2 together, pass slipped st over) or p3 together, k 3 sts.

Continue on the remaining **23-25-27-29** sts until piece measures **27-31-35-39** cm (**10¾-12¼-13¾-15¼** in) [**76-88-100-110** rows] total.

Cast off all sts.

FRONT:

Work as for back.

STRAPS (2):

Using A, cast on **5** sts. Work in Seed st for **19** cm (**7½** in) [**60** rows].

Cast off all sts.

FINISHING:

Sew side seams of dress.

Sew one end of each strap to edge of back neck (see red lines on diagram).

Attach one button to each strap, 3 cm (1¼ in) from other end.

To wear, slip buttons through front sts, 1 cm (½ in) in from neck edge.

Secure and weave in ends.

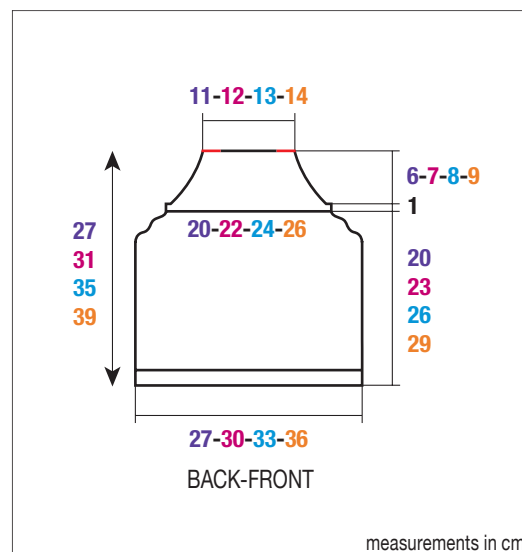

le Wooling

SPECIAL ISSUE

NEW

2
DIFFERENT
LE WOOLING
SPECIAL
ISSUES



SPECIAL ISSUE - ORILIS
WOMEN - KIDS - LAYETTE
10 PATTERNS - REF. 72688

SPECIAL ISSUE - COTON SATINÉ
WOMEN - KIDS - LAYETTE
10 PATTERNS - REF. 72683

*Browse the
magazines online*

ref. 726.83



3 661004 726838